

Product Name	Description	Version
LC20030-Vx	Dual-frequency multi-constellation GNSS smart antenna, USB	1.2
LC20031-Vx	Dual-frequency multi-constellation GNSS smart antenna, TTL	
LC20032-Vx	Dual-frequency multi-constellation GNSS smart antenna, RS232	

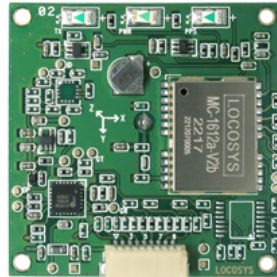

Antenna side



LC20030-Vx

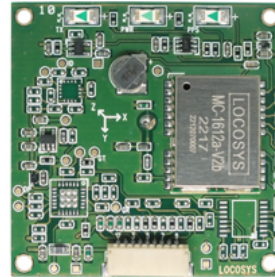

LC20031-Vx

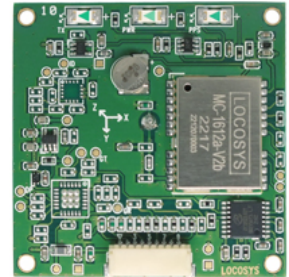

LC20032-Vx

1 Introduction

LC2003x-Vx series products are high-performance dual-band GNSS smart antenna modules, including an embedded antenna and GNSS receiver circuits, designed for a broad spectrum of OEM system applications. The GNSS smart antenna will acquire both L1 and L5 signals at a time while providing the better standalone position accuracy. It can provide you with fast Time-To-First-Fix, superior sensitivity and low power consumption. Its far-reaching capability meets the sensitivity requirements of car navigation as well as other location-based applications.

2 Features

- Concurrent reception of L1 and L5 band signals
- Support GPS, GLONASS, BEIDOU, GALILEO, QZSS and NavIC
- Capable of SBAS (WAAS, EGNOS, MSAS, GAGAN) and QZSS SLAS
- Support 135-channel GNSS
- Fast TTFF at low signal level
- Free hybrid ephemeris prediction to achieve faster cold start
- Smart jammer detection and suppression
- Build-in gold capacitor to reserve system data for rapid satellite acquisition
- LED indicator for GNSS fix or not

3 Application

- Personal positioning and navigation
- Automotive navigation and fleet management
- Marine navigation

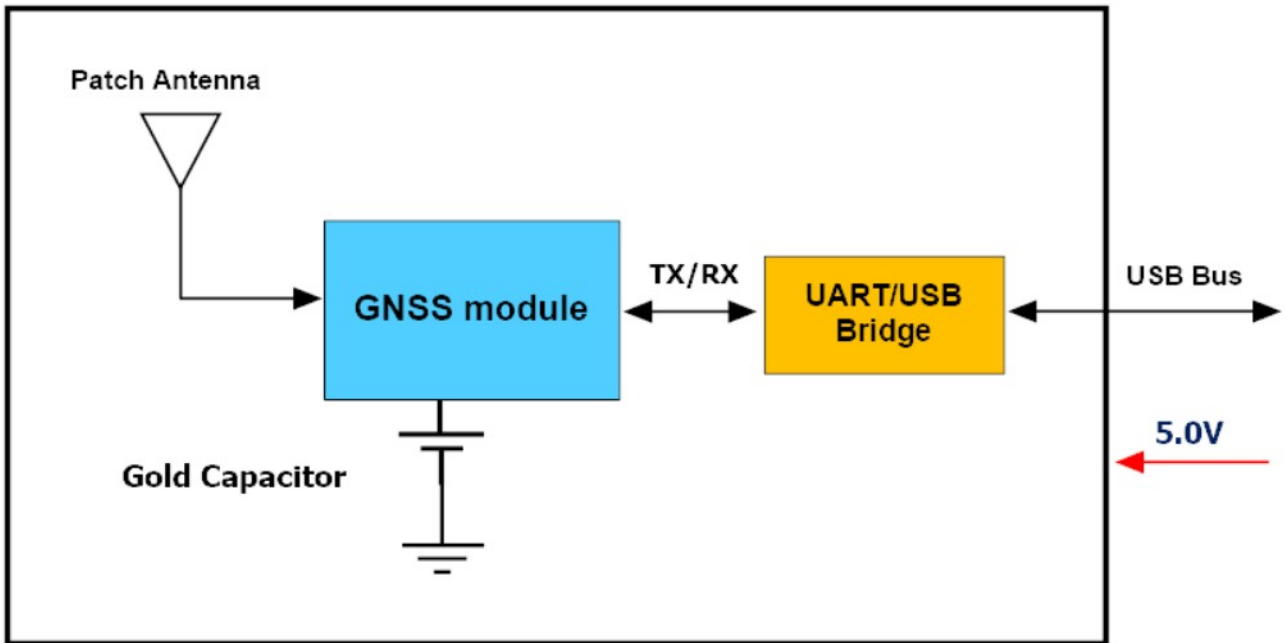

Fig 3-1 System block diagram of LC20030-Vx

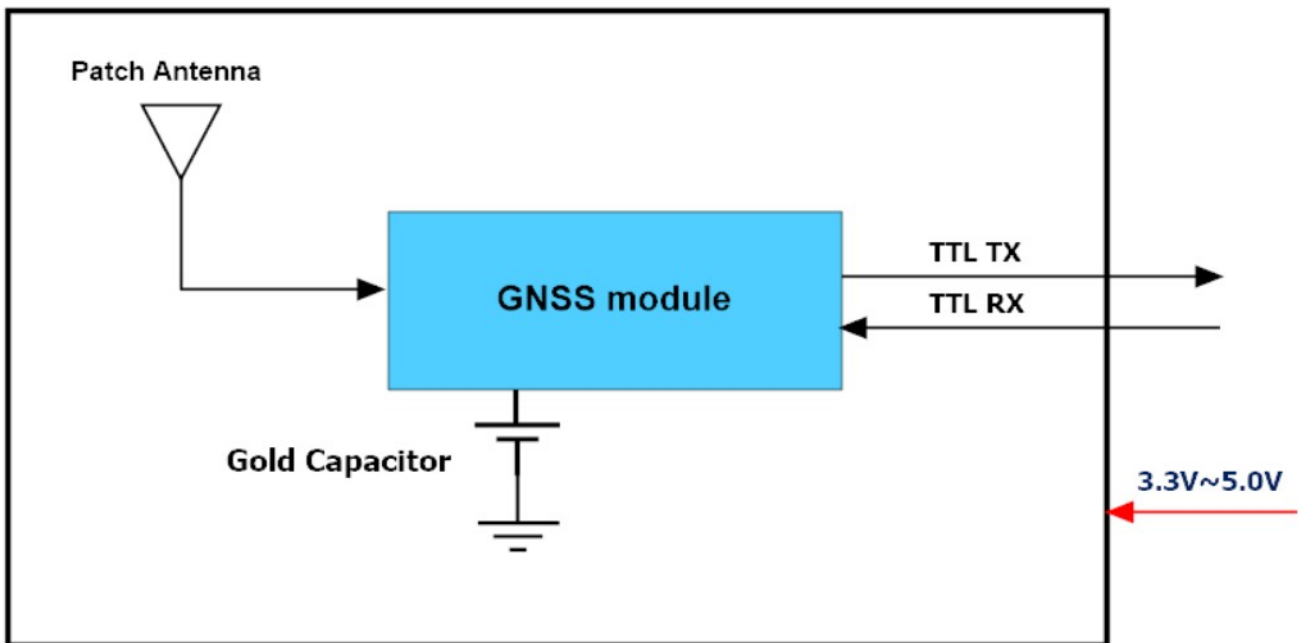

Fig 3-2 System block diagram of LC20031-Vx

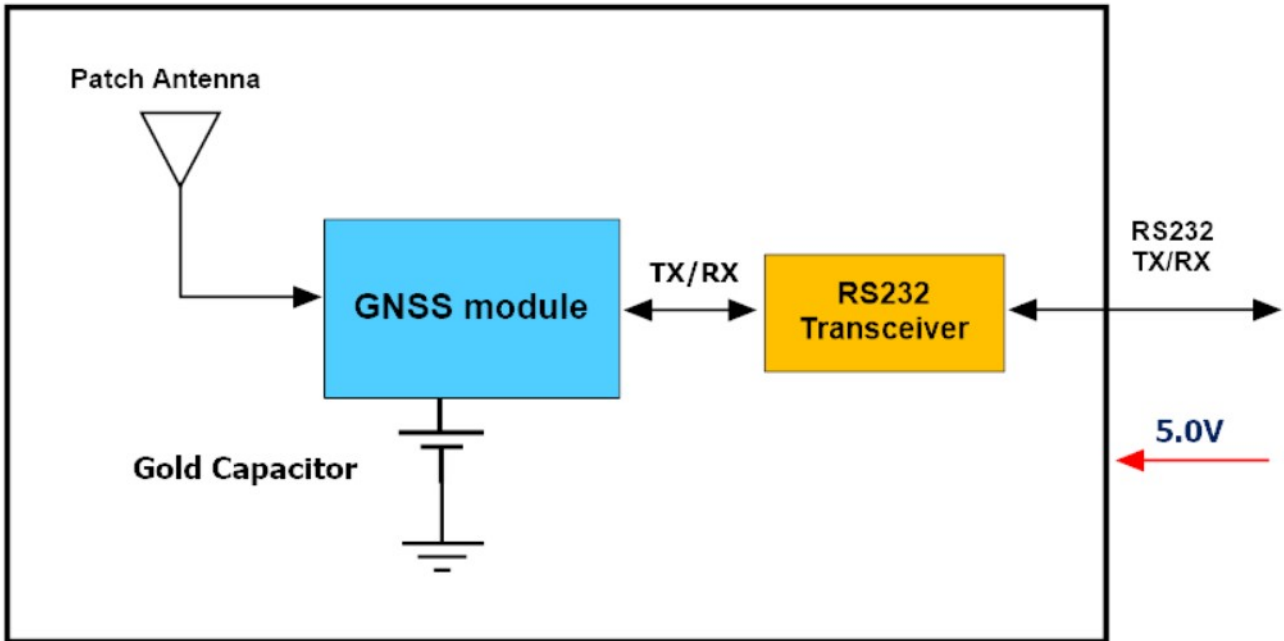

Fig 3-3 System block diagram of LC20032-Vx

4 GNSS receiver

Frequency	LC20030-V2 LC20031-V2 LC20032-V2	GPS/QZSS: L1 C/A, L5C GLONASS: L1OF BEIDOU: B1I, B2a GALILEO: E1, E5a NavIC: L5
	LC20030-V3 LC20031-V3 LC20032-V3	GPS/QZSS: L1 C/A GLONASS: L1OF BEIDOU: B1I GALILEO: E1 NavIC: L5
Channels	Support 135 channels	
Update rate	1Hz default, up to 10Hz	
Acquisition Time	Hot start (Open Sky)	2s (typical)
	Cold Start (Open Sky)	28s (typical) without AGPS
Position Accuracy	LC20030-V2 LC20031-V2 LC20032-V2	Autonomous: 1.5m (CEP)
	LC20030-V3 LC20031-V3 LC20032-V3	Autonomous: 2.5m (CEP)
Datum	WGS-84 (default)	
Max. Altitude	< 18,000 m	
Max. Velocity	< 500 m/s	
Protocol Support	NMEA 0183 ver. 4.1	115200 bps , 8 data bits, no parity, 1 stop bits (default) 1Hz: GGA, GLL, GSA, GSV, RMC, VTG, GST

5 Software interface

5.1 NMEA output message

Table 5.1-1 NMEA output message

NMEA record	Description
GGA	Global positioning system fixed data
GLL	Geographic position - latitude/longitude
GSA	GNSS DOP and active satellites
GSV	GNSS satellites in view
RMC	Recommended minimum specific GNSS data
VTG	Course over ground and ground speed
GST	Estimated error in position solution

- **GGA--- Global Positioning System Fixed Data**

Table 5.1-2 contains the values for the following example:

\$GNGGA,091250.000,2503.71250,N,12138.74514,E,1,32,0.55,119.0,M,17.2,M,,*7E

Table 5.1-2 GGA Data Format

Name	Example	Units	Description
Message ID	\$GNGGA		GGA protocol header
UTC Time	091250.000		hhmmss.sss
Latitude	2503.71250		ddmm.mmmmm
N/S indicator	N		N=north or S=south
Longitude	12138.74514		dddmm.mmmmm
E/W Indicator	E		E=east or W=west
Position Fix Indicator	1		See Table 5.1-3
Satellites Used	32		Number of satellites in use
HDOP	0.55		Horizontal Dilution of Precision (meters)
MSL Altitude	119.0	meters	Antenna Altitude above/below mean-sea-level (geoid) (in meters)
Units	M	meters	Units of antenna altitude, meters
Geoidal Separation	17.2	meters	
Units	M	meters	Units of geoidal separation, meters
Age of diff. GNSS data		second	Null fields when DGPS is not used
Diff. Ref. Station ID			Differential reference station ID, 0000-1023
Checksum	*7E		Checksum
<CR> <LF>			End of message termination

Table 5.1-3 Position Fix Indicators

Value	Description
0	No position fix
1	Autonomous GNSS fix
2	Differential GNSS fix

- **GLL--- Geographic Position – Latitude/Longitude**

Table 5.1-4 contains the values for the following example:

\$GNGLL,2503.71193,N,12138.74582,E,094450.000,A,A*47

Table 5.1-4 GLL Data Format

Name	Example	Units	Description
Message ID	\$GNGLL		GLL protocol header
Latitude	2503.71193		ddmm.mmmmm
N/S indicator	N		N=north or S=south
Longitude	12138.74582		dddmm.mmmmm
E/W indicator	E		E=east or W=west
UTC Time	094450.000		hhmmss.sss
Status	A		A=data valid or V=data not valid
Mode	A		N = No position fix A = Autonomous GNSS fix D = Differential GNSS fix E = Estimated/Dead reckoning fix
Checksum	*47		
<CR> <LF>			End of message termination

- **GSA---GNSS DOP and Active Satellites**

Table 5.1-5 contains the values for the following example:

\$GNGSA,A,3,11,195,194,199,08,07,01,27,16,09,23,,1.19,0.64,1.00,1*3F

\$GNGSA,A,3,87,81,76,,,,,,,,,1.19,0.64,1.00,2*0F

\$GNGSA,A,3,,,,,,,,,,,,,1.19,0.64,1.00,3*09

\$GNGSA,A,3,34,24,12,07,11,10,08,38,25,09,13,16,1.19,0.64,1.00,4*02

Table 5.1-5 GSA Data Format

Name	Example	Units	Description
Message ID	\$GNGSA		GSA protocol header
Mode 1	A		See Table 5.1-6
Mode 2	3		See Table 5.1-7
ID of satellite used	11		SV on Channel 1

ID of satellite used	195		SV on Channel 2
....		
ID of satellite used			SV on Channel 12
PDOP	1.19		Position Dilution of Precision
HDOP	0.64		Horizontal Dilution of Precision
VDOP	1.00		Vertical Dilution of Precision
GNSS system ID	4		See Table 5.1-8
Checksum	*3F		
<CR> <LF>			End of message termination

Table 5.1-6 Mode 1

Value	Description
M	Manually set to operate in 2D or 3D mode
A	Automatically switching between 2D or 3D mode

Table 5.1-7 Mode 2

Value	Description
1	No position fix
2	2D fix
3	3D fix

Table 5.1-8 GNSS system ID

Value	Description
1	GPS
2	GLONASS
3	GALILEO
4	BEIDOU
6	NavIC

● GSV---GNSS Satellites in View

Table 5.1-9 contains the values for the following example:

```
$GPGSV,3,1,09,8,71,268,47,27,63,18,49,11,44,191,46,4,41,237,46,1*54
$GPGSV,3,2,09,16,38,42,42,9,32,279,39,26,22,70,38,31,15,131,36,1*56
$GPGSV,3,3,09,7,15,320,40,1*6B
$GPGSV,1,1,04,8,71,268,50,27,63,18,49,9,32,279,43,26,22,70,42,8*6C
$GLGSV,2,1,05,82,63,47,47,83,56,182,36,80,47,9,42,79,33,85,45,1*71
$GLGSV,2,2,05,81,15,27,37,1*71
$GAGSV,1,1,04,08,48,300,43,03,47,025,45,13,36,309,42,05,06,061,34,7*79
$GAGSV,1,1,04,08,48,300,43,03,47,025,47,13,36,309,43,05,06,061,33,1*7B
$GBGSV,5,1,17,12,80,182,47,24,64,5,51,7,58,355,44,3,57,205,45,1*7C
```

```
$GBGSV,5,2,17,1,54,141,44,34,52,211,49,9,48,230,45,10,47,316,42,1*79
$GBGSV,5,3,17,26,44,100,47,16,39,207,43,4,38,117,41,2,37,240,41,1*77
$GBGSV,5,4,17,39,37,210,43,6,36,198,41,38,27,173,41,25,18,317,42,1*4E
$GBGSV,5,5,17,35,16,39,40,1*7F
$GBGSV,1,1,02,24,64,5,50,26,44,100,43,4*77
```

Table 5.1-9 GSV Data Format

Name	Example	Units	Description
Message ID	\$GPGSV		GSV protocol header. GP=GPS/QZSS, GL=GLONSS, GA=GALILEO, GB=BEIDOU, GI=NavIC
Total number of messages	3		Range 1 to 9
Message number	1		Range 1 to 9
Satellites in view	09		
Satellite ID	8		Channel 1
Elevation	71	degrees	Channel 1 (Range 00 to 90)
Azimuth	268	degrees	Channel 1 (Range 000 to 359)
SNR (C/No)	47	dB-Hz	Channel 1 (Range 00 to 99, null when not tracking)
....		
Satellite ID	4		Channel 4 (Range 01 to 196)
Elevation	41	degrees	Channel 4 (Range 00 to 90)
Azimuth	237	degrees	Channel 4 (Range 000 to 359)
SNR (C/No)	46	dB-Hz	Channel 4 (Range 00 to 99, null when not tracking)
Signal ID	1		GPS/QZSS: L1 C/A=1, L5Q=8 GLONASS: L1 C/A=1 GALILEO: E1=7, E5a=1 BEIDOU: B1=1, B2a=4 NavIC: L5=1
Checksum	*54		
<CR> <LF>			End of message termination

● **RMC---Recommended Minimum Specific GNSS Data**

Table 5.1-10 contains the values for the following example:

```
$GNRMC,070143.000,A,2503.71317,N,12138.74533,E,0.002,70.50,130220,,A,V*01
```

Table 5.1-10 RMC Data Format

Name	Example	Units	Description
Message ID	\$GNRMC		RMC protocol header
UTC Time	070143.000		hhmmss.sss

Status	A		A=data valid or V=data not valid
Latitude	2503.7117		ddmm.mmmm
N/S Indicator	N		N=north or S=south
Longitude	12138.74533		dddmm.mmmmm
E/W Indicator	E		E=east or W=west
Speed over ground	0.002	knots	True
Course over ground	70.50	degrees	
Date	130220		ddmmyy
Magnetic variation		degrees	
Variation sense			E=east or W=west
Mode	A		N = No position fix A = Autonomous GNSS fix D = Differential GNSS fix E = Estimated/Dead reckoning fix
Navigational status indicator	V		S = Safe C = Caution U = Unsafe V = Void
Checksum	*01		
<CR> <LF>			End of message termination

● **VTG---Course Over Ground and Ground Speed**

Table 5.1-11 contains the values for the following example:

\$GNVTG,0.00,T,,M,0.003,N,0.006,K,A*26

Table 5.1-11 VTG Data Format

Name	Example	Units	Description
Message ID	\$GNVTG		VTG protocol header
Course over ground	0.00	degrees	Measured heading
Reference	T		True
Course over ground		degrees	Measured heading
Reference	M		Magnetic
Speed over ground	0.003	knots	Measured speed
Units	N		Knots
Speed over ground	0.006	km/hr	Measured speed
Units	K		Kilometer per hour
Mode	A		N = No position fix A = Autonomous GNSS fix

			D = Differential GNSS fix E = Estimated/Dead reckoning fix
Checksum	*26		
<CR> <LF>			End of message termination

● **GST---Estimated error in position solution**

Table 5.1-12 contains the values for the following example:

\$GNGST,075707.000,2.9,1.8,1.5,113.3,1.6,1.8,5.9*7F

Table 5.1-12 GST Data Format

Name	Example	Units	Description
Message ID	\$GNGST		GST protocol header
UTC Time	075707.000		hhmmss.sss
RangeRMS	2.9	meters	RMS value of the standard deviation of the ranges
stdMajor	1.8	meters	Standard deviation of semi-major axis of error ellipse
stdMinor	1.5	meters	Standard deviation of semi-minor axis of error ellipse
Orient	113.3	degrees	Orientation of semi-major axis of error ellipse
stdLat	1.6	meters	Standard deviation of latitude error
stdLong	1.8	meters	Standard deviation of longitude error
stdAlt	5.9	meters	Standard deviation of altitude error
Checksum	*7F		
<CR> <LF>			End of message termination

5.2 Proprietary command

The commonly used commands are in the following.

5.2.1 ID: 004

[Description]

Hot Start. Use the available data in the NVRAM.

[Data Field]

\$PAIR004*CS<CR><LF>

[Return]

PAIR_ACK for send result.

[Example]

Send:

\$PAIR004*3E\r\n

Response:

\$PAIR001,004,0*3F\r\n ==> Success

5.2.2 ID: 005

[Description]

Warm Start. Not using Ephemeris data at the start.

[Data Field]

\$PAIR005*CS<CR><LF>

[Return]

PAIR_ACK for send result.

[Example]

Send:

\$PAIR005*3F\r\n

Response:

\$PAIR001,005,0*3E\r\n ==> Success

5.2.3 ID: 006

[Description]

Cold Start. Not using the Position, Almanac and Ephemeris data at the start.

[Data Field]

\$PAIR006*CS<CR><LF>

[Return]

PAIR_ACK for send result.

[Example]

Send:

\$PAIR006*3C\r\n

Response:

\$PAIR001,006,0*3D\r\n ==> Success

6 LED indicator

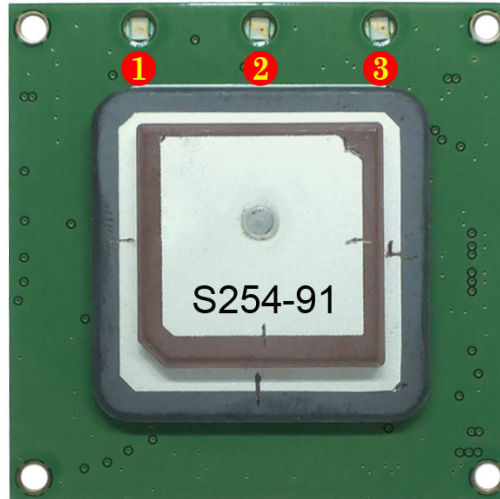

LED	Color	Descriptions
1	Blue	PPS Indicator
2	Red	Power Indicator
3	Green	TX Indicator

7 Pin assignment and descriptions

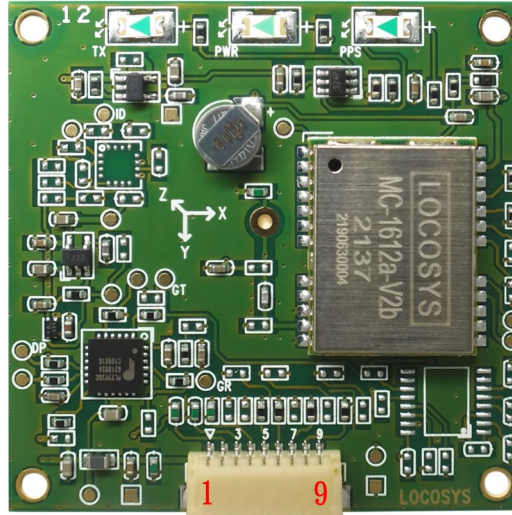

● **LC20030-Vx**

Pin #	Name	Type	Description
1	VCC	I	DC supply input.
2	USB_DM		USB D-
3	USB_DP		USB D+
4	TIMEPULSE*	O	PPS, default 100ms pulse/sec when 3D fix is available
5	GND	P	Ground
6	GND	P	Ground
7	GND	P	Ground
8	GND	P	Ground
9	GND	P	Ground

Note: The Timepulse(PPS) signal also connect to DCD(Data Carrier Detect) pin.

● **LC20031-Vx**

Pin #	Name	Type	Description
1	VCC	I	DC supply input.
2	RXD	I	UART, asynchronous input, TTL level
3	TXD	O	UART, asynchronous output, TTL level
4	TIMEPULSE	O	PPS, default 100ms pulse/sec when 3D fix is available
5	GND	P	Ground
6	GND	P	Ground
7	GND	P	Ground
8	GND	P	Ground
9	GND	P	Ground

● **LC20032-Vx**

Pin #	Name	Type	Description
1	VCC	I	DC supply input.
2	RXD	I	UART, asynchronous input, RS232 level
3	TXD	O	UART, asynchronous output, RS232 level
4	TIMEPULSE	O	PPS, default 100ms pulse/sec when 3D fix is available
5	GND	P	Ground
6	GND	P	Ground
7	GND	P	Ground
8	GND	P	Ground
9	GND	P	Ground

<Note>

The input voltage from 0 to its working voltage must be a stable rising slope. Avoid powering the module at the same time during mechanical contact of the connector. This may make the module not work even if the correct voltage is input again. When this happens, the user has to disconnect the power and wait around 15 minutes until the built-in gold capacitor is exhausted.

8 DC & Temperature characteristics

8.1 DC Electrical characteristics

Parameter	Symbol	Product	Min.	Typ.	Max.	Units
Input voltage	VCC	LC20030-Vx	4.75	5.0	5.25	V
		LC20031-Vx	3.30	3.3	5.25	
		LC20032-Vx	4.75	5.0	5.25	
Input current ⁽¹⁾	Icc	LC20030-V2		76		mA
		LC20031-V2		65		
		LC20032-V2		69		
		LC20030-V3		52		
		LC20031-V3		42		
		LC20032-V3		46		
High Level Input Voltage	V _{IH}	LC20031-Vx	0.7*VCC		VCC	V
Low Level Input Voltage	V _{IL}	LC20031-Vx	0		0.2*VCC	V
High Level Output Voltage	V _{OH}	LC20031-Vx	VCC-0.4			V
Low Level Output Voltage	V _{OL}	LC20031-Vx			0.4	V
High Level Output Current	I _{OH}	LC20031-Vx		4		mA
Low Level Output Current	I _{OL}	LC20031-Vx		4		mA

Note 1: Measured when position fix (1Hz) is available, the function of self-generated ephemeris prediction is inactive.

8.2 Temperature characteristics

Parameter	Symbol	Min.	Typ.	Max.	Units
Operating Temperature	Topr	-10	-	60	°C
Storage Temperature	Tstg	-10	25	60	°C

9 Mechanical specification

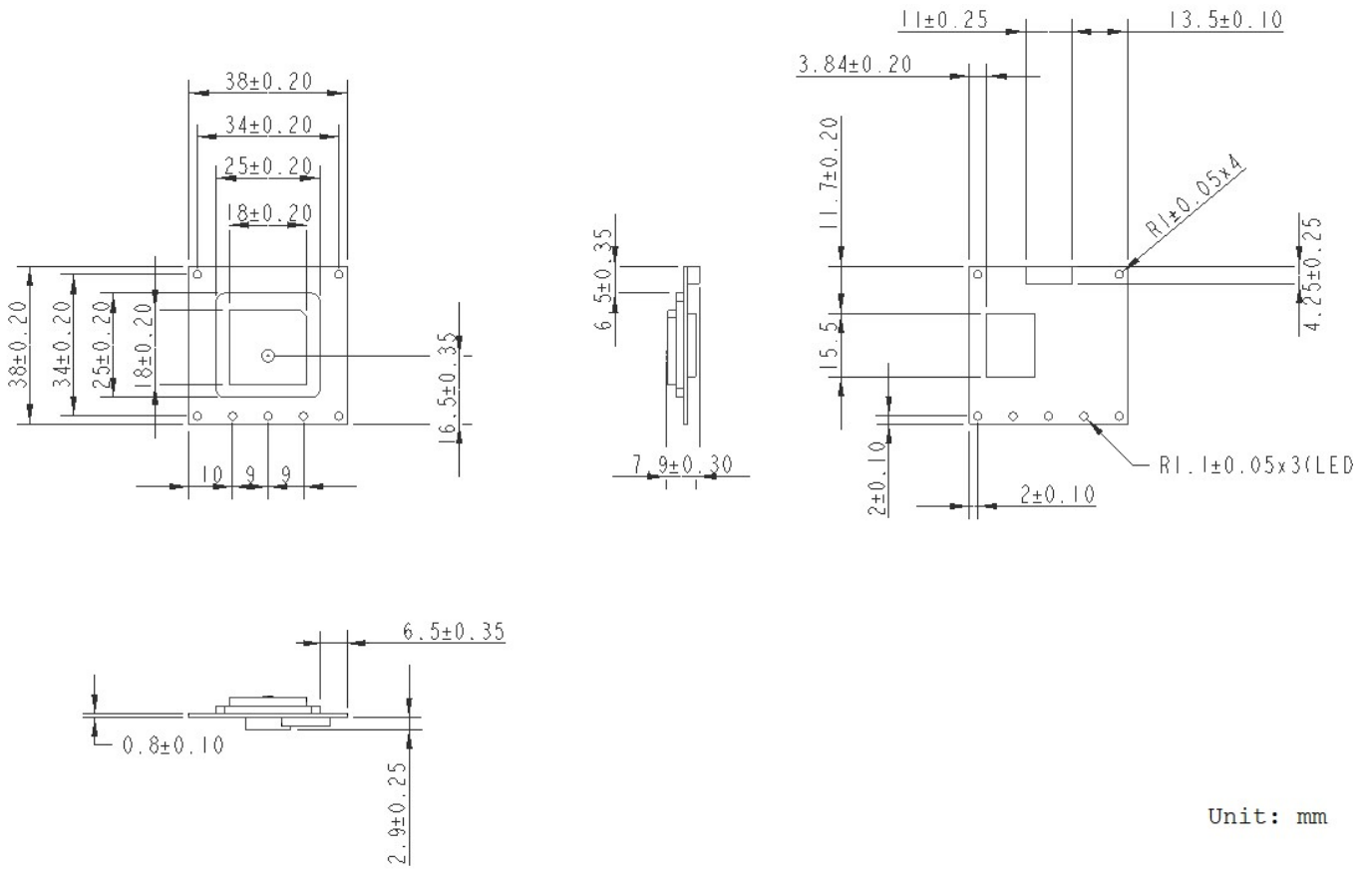

Unit: mm

10 Product handling

10.1 ESD precaution

GNSS modules are electrostatic sensitive devices. Handling the modules without proper ESD protection may result in severe damage to them. ESD protection must be implemented throughout the processing, handling and even when the modules are being returned for repair.

10.2 Packaging

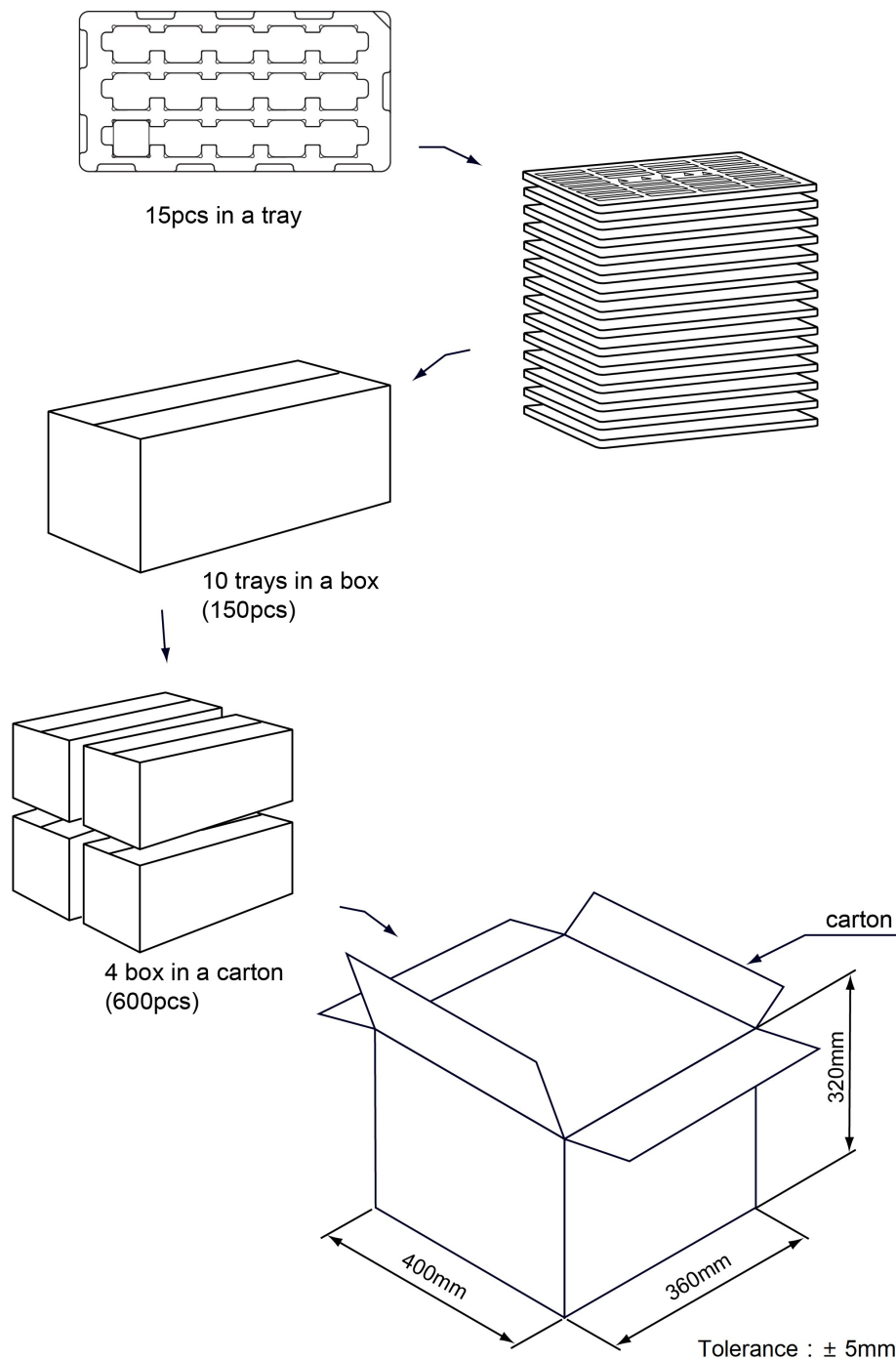

11 Ordering information

Product name	Description	Remark
LC20030-V2	Dual-frequency multi-constellation GNSS smart antenna, USB	GPS/QZSS: L1 C/A, L5C GLONASS: L1OF BEIDOU: B1I, B2a GALILEO: E1, E5a NavIC:L5
LC20031-V2	Dual-frequency multi-constellation GNSS smart antenna, TTL	
LC20032-V2	Dual-frequency multi-constellation GNSS smart antenna, RS232	
LC20030-V3	Dual-frequency multi-constellation GNSS smart antenna, USB	GPS/QZSS: L1 C/A GLONASS: L1OF BEIDOU: B1I GALILEO: E1 NavIC: L5
LC20031-V3	Dual-frequency multi-constellation GNSS smart antenna, TTL	
LC20032-V3	Dual-frequency multi-constellation GNSS smart antenna, RS232	

Document change list

Revision 0.1

- Draft release on Apr 29, 2022.

Revision 0.2 (May 11, 2022)

- Revised the mechanical specification in section 9.
- Added Section 10.2.

Revision 1.0 (June 2, 2023)

- Changed pin 5、6、7、8 from NC to GND in section 7.
- Added the note in section 7.
- Changed the current of LC20030-V2 from 73mA to 76mA in section 8.1.
- Changed the current of LC20031-V2 from 64mA to 65mA in section 8.1.
- Changed the current of LC20032-V2 from 67mA to 69mA in section 8.1.
- Changed the current of LC20030-V3 from 54mA to 52mA in section 8.1.
- Changed the current of LC20032-V3 from 43mA to 46mA in section 8.1.
- Changed the operating and storage temperature (Min.) from -20°C to -10 °C in section 8.2.
- Add the tolerance in section 9.

Revision 1.1 (December 19, 2023)

- Removed the storage the section 10.3.

Revision 1.2 (July 04, 2024)

- LC20030-V2、LC20031-V2 and LC20032-V2 can support NavIC.