

Product name	Description	Version
HD-1612-BA	Datasheet of HD-1612-BA standalone GNSS module	1.0



1 Introduction

LOCOSYS HD-1612-BA is a complete standalone GNSS module which uses ALLYSTAR latest HD8020 GNSS chip to integrate with an additional LNA and SAW filter. The module can simultaneously acquire and track multiple satellite constellations that include GPS, BEIDOU, GALILEO, QZSS and SBAS. It features low power and small form factor. Besides, it can provide you with superior sensitivity and performance even in urban canyon and dense foliage environment.

2 Features

- ALLYSTAR high sensitivity solution
- Support GPS, BEIDOU, GALILEO and QZSS
- Capable of SBAS (WAAS, EGNOS, MSAS, GAGAN)
- Support up to 72-channel GNSS
- Fast TTFF at low signal level
- Support 1PPS output
- Built-in DC/DC converter to save power
- Built-in additional LNA and SAW filter
- Embedded an active antenna supervisor
- SMD type; RoHS compliant
- Qualification according to ISO 16750
- IATF 16949 quality control

3 Application

- Personal positioning and navigation
- Automotive navigation, model aircraft navigation
- Marine navigation

4 Overview
 4.1 Block Diagram

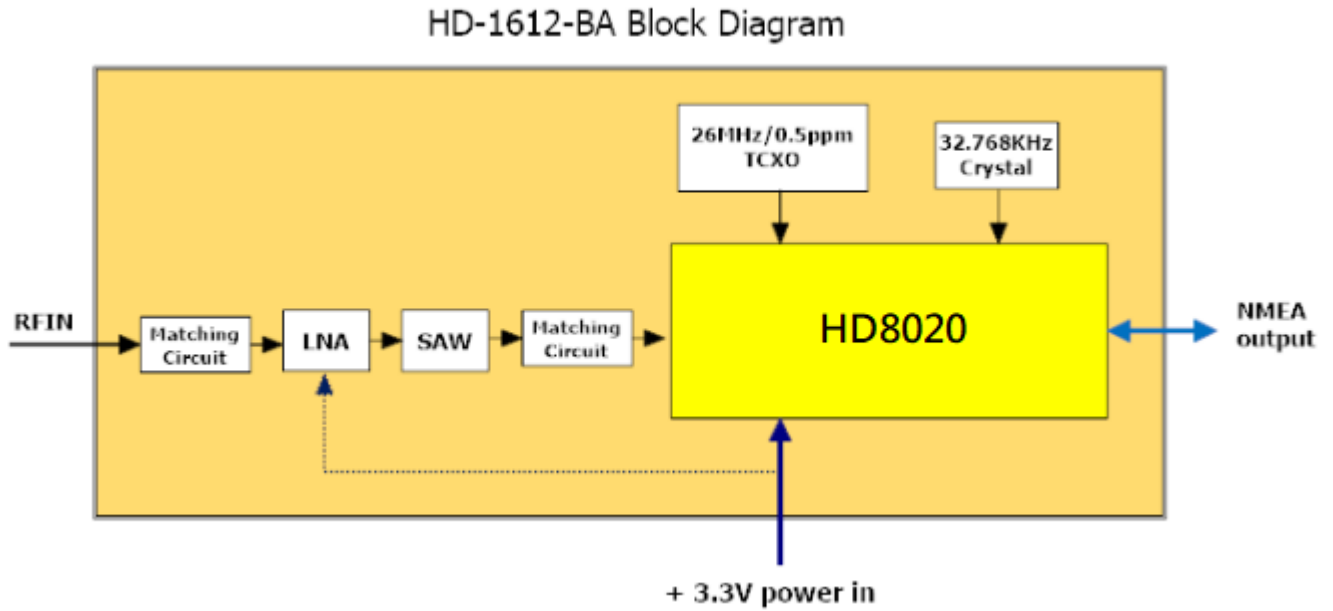

4.2 GNSS Performance

Chip	HD8020	
Frequency	GPS, GALILEO, QZSS: L1 1575.42MHz, C/A code BEIDOU: B1 1561.098MHz, C/A code	
Channels	Up to 72 channels	
Update rate	1Hz default	
Sensitivity	Tracking	-160dBm up to -161dBm (with external LNA)
	Cold start	-146.5dBm up to -148dBm (with external LNA)
Acquisition Time	Hot start (Open Sky)	< 1s (typical)
	Cold Start (Open Sky)	28s (typical)
Position Accuracy	Autonomous	2.5m CEP
Max. Altitude	< 18,000 m	
Max. Velocity	< 515 m/s	
Protocol Support	NMEA 0183 ver 4.0	9600bps (1), 8 data bits, no parity, 1 stop bits (default)
		1Hz: GGA, GLL, GSA, GSV, RMC, and VTG

Note 1. Both baud rate and output message rate are configurable to be factory default.

4.3 Passive antenna application circuit diagram

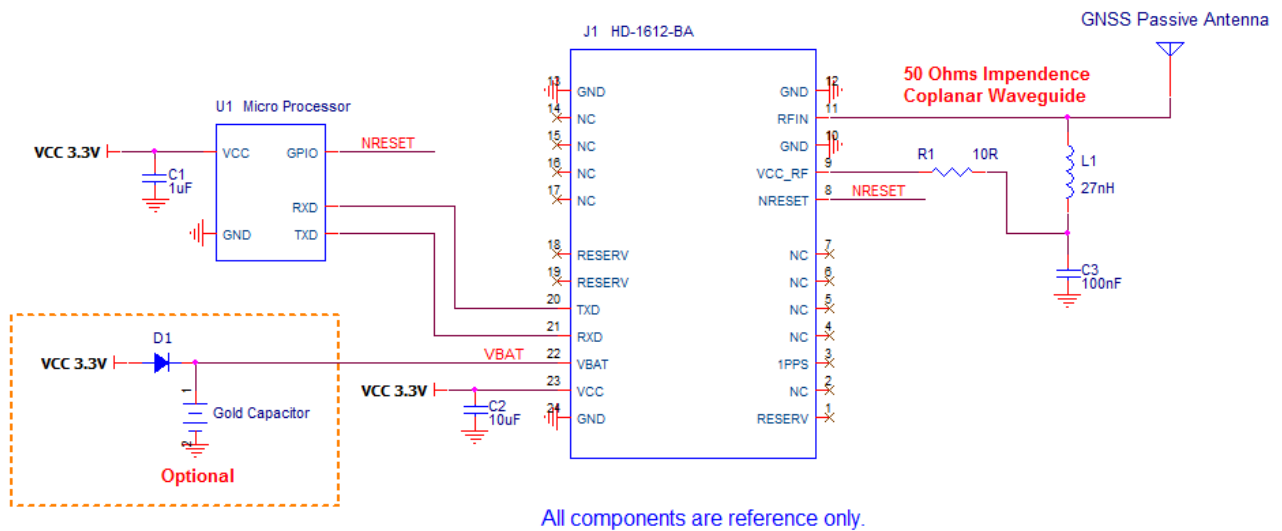

4.4 Active antenna application supervisor circuit diagram

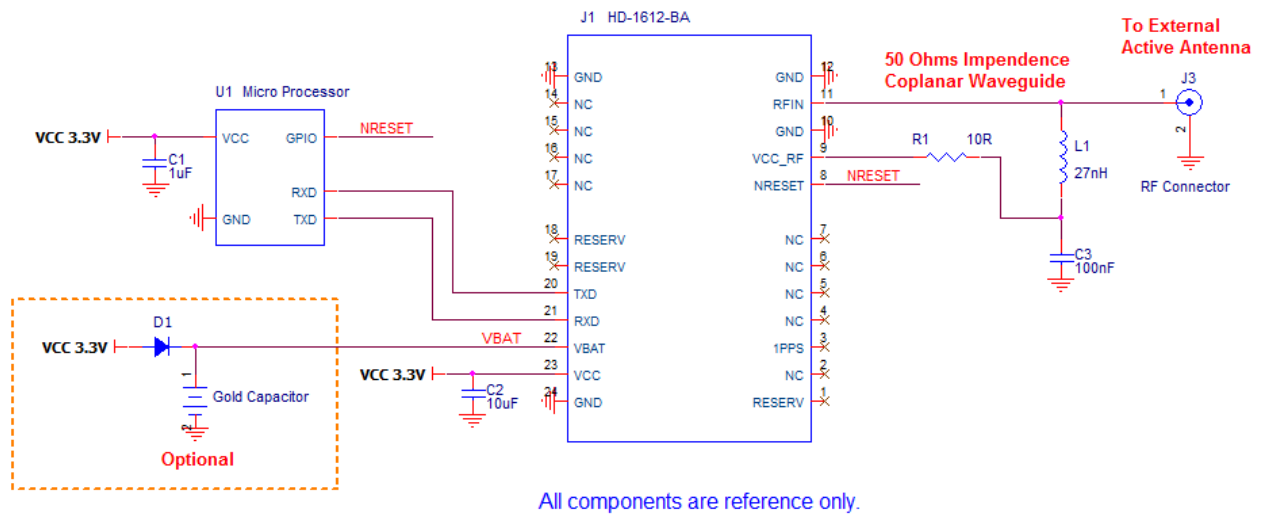

Table 4-1 Antenna status in NMEA sentence

Active antenna status	Output message per second from GNSS module
Antenna is short.	\$GNTXT,01,01,01,ANT_SHORT*06
Antenna is well connected.	\$GNTXT,01,01,01,ANT_OK*50
Antenna is open, i.e. not connected.	\$GNTXT,01,01,01,ANT_OPEN*40

4.5 Pin assignment and descriptions (Top View)

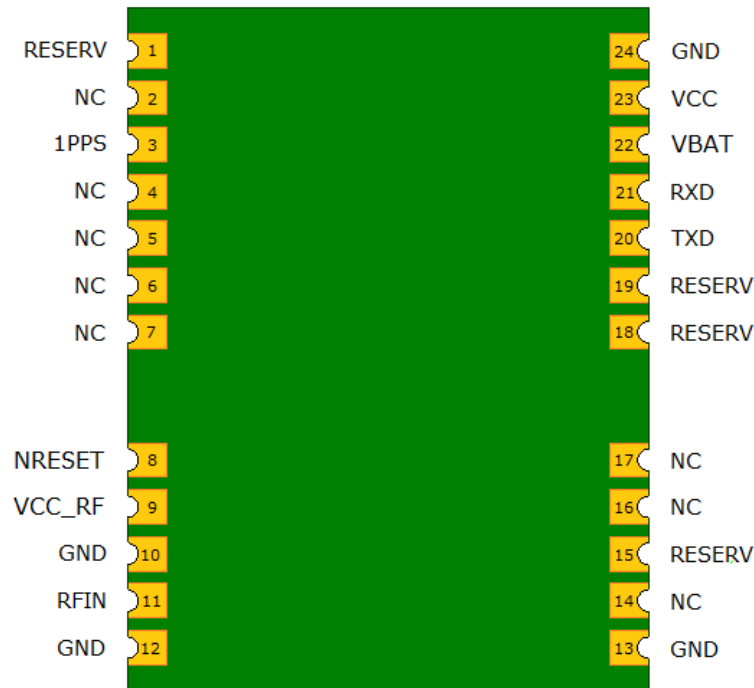

Table 4-2 Pin descriptions

Pin #	Name	Type	Description	Note
1	RESERV		Manufacture used, keep open.	
2	NC		No connect	
3	1PPS	O	Time pulse (1PPS, default 100 ms pulse/sec when 3D fix is available)	
4	NC		No connect	
5	NC		No connect	
6	NC		No connect	
7	NC		Not connect	
8	RESERV		Reset input, active low; keep open if unused.	1
9	VCC_RF	P	Power to external active antenna (antenna short circuit detection pin).	
10	GND	G	Ground	
11	RFIN	RF	GNSS matched RF input, DC block inside.	2
12	GND	G	Ground	
13	GND	G	Ground	
14	NC		No connect	
15	RESERV		Reserved, keep floating	
16	NC		No connect	
17	NC		No connect	

18	RESERV		Reserved, keep floating	
19	RESERV		Reserved, keep floating	
20	TXD	O	UART, asynchronous output	
21	RXD	I	UART, asynchronous input	
22	VBAT	P	Backup power input	
23	VCC	P	Main power supply	
24	GND	G	Ground	

Note:

1. The module will not work if you follow the design of NEO-5/NEO-6 pin defines, short circuit pin8 & pin9. Contact us if any further information for NEO-5/NEO-6 compatible design is needed.
2. Coplanar waveguide is recommended.

5 DC & Temperature characteristics

5.1 Absolute maximum ratings

Parameter	Symbol	Ratings	Units
DC Supply Voltage	VCC	3.6	V
Input Backup Battery Voltage	V_BCKP	3.6	V
Operating Temperature Range	Topr	-40 ~ 85	°C
Storage Temperature Range	Tstg	-40 ~ 85	°C

5.2 DC Electrical characteristics

Parameter	Symbol	Conditions	Min.	Typ.	Max.	Units
Input Voltage	VCC		3.0	3.3	3.6	V
Input Backup Battery Voltage	V_BCKP		1.6		3.6	V
VCC_RF Output Voltage	VOUT			0.95*VCC		V
Supply Current	Iss	VCC = 3.3V, w/o active antenna, Peak Acquisition Tracking			136	mA
				54		mA
				30		mA
Backup Battery Current	Ibat	Remove the power of VCC		13		uA
VCC_RF Output Current	Iout	VIN = 3.3V			40	mA
High Level Input Voltage	V _{IH}		0.67*VCC		VCC	V
Low Level Input Voltage	V _{IL}		0		0.9	V
High Level Output Voltage	V _{OH}		0.67*VCC		VCC	V
Low Level Output Voltage	V _{OL}				0.4	V
High Level Output Current	I _{OH}			2		mA
Low Level Output Current	I _{OL}			2		mA

5.3 Temperature characteristics

Parameter	Symbol	Min.	Typ.	Max.	Units
Operating Temperature	Topr	-40	-	85	°C
Storage Temperature	Tstg	-40	25	85	°C

6 Mechanical specification
 6.1 Outline dimensions

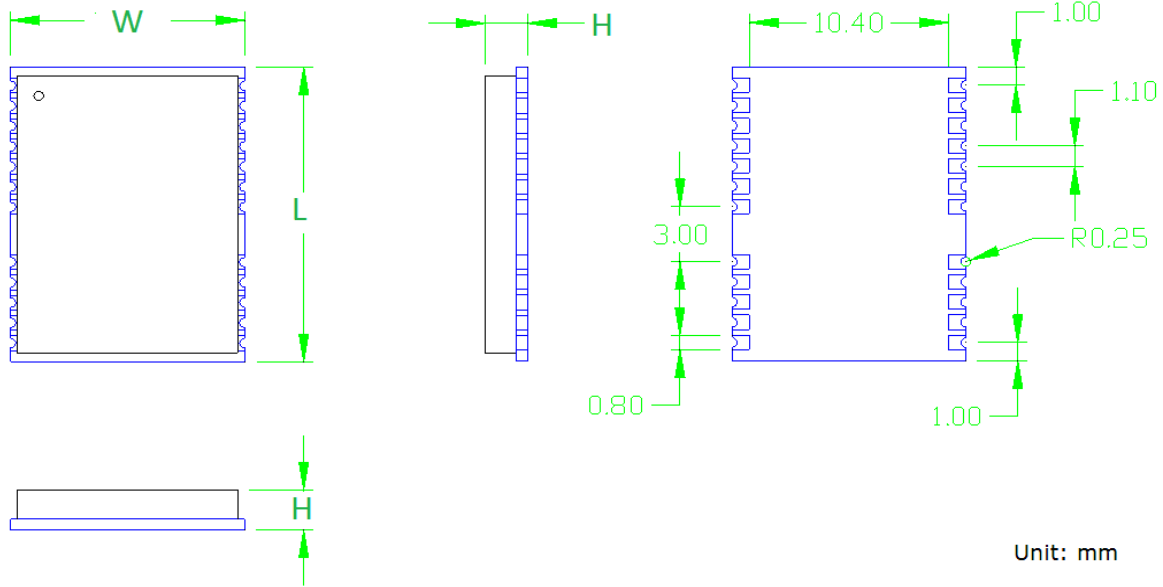

Symbol	Min. (mm)	Typ. (mm)	Max. (mm)
W	12.10	12.18	12.30
L	15.75	16.06	16.25
H	2.05	2.22	2.35

6.2 Recommended land pattern dimensions

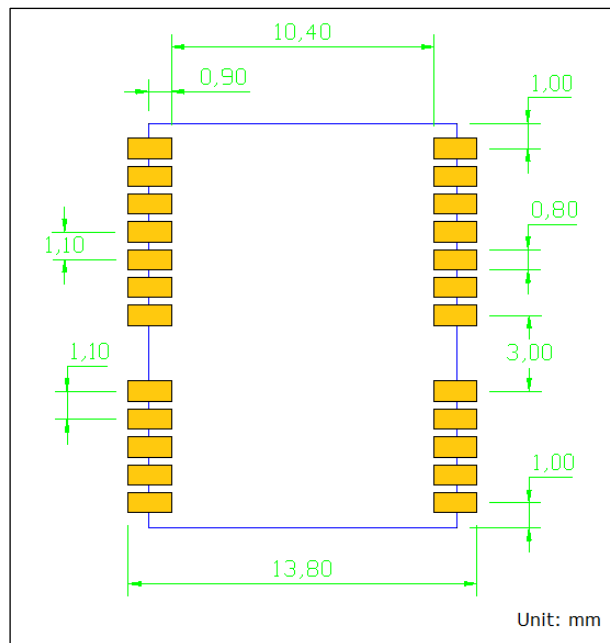

Note: The recommended land pattern dimensions are shown for reference only, as actual pad layouts may vary depending on application.

7 Software interface

7.1 NMEA output message

Table 7.1-1 NMEA output message

NMEA	Description
GGA	Global positioning system fixed data
GLL	Geographic position - latitude/longitude
GSA	GNSS Overall satellite data
GSV	GNSS Detailed satellite data
RMC	Recommended minimal data for GNSS
VTG	Course over ground and ground speed
ZDA (optional)	Date and time

● **GGA Global positioning system fixed data**

Table 7.1-2 contains the values for the following example:

\$GNGGA,053021.000,2503.71517,N,12138.74845,E,1,14,0.75,140.3,M,17.2,M,,*70

Table 7.1-2 GGA Data Format

Name	Example	Units	Description
Message ID	\$GNGGA		GGA protocol header
UTC Time	053021.000		hhmmss.sss
Latitude	2503.71517		ddmm.mmmmm
N/S indicator	N		N=north or S=south
Longitude	12138.74845		dddmm.mmmmm
E/W Indicator	E		E=east or W=west
Position Fix Indicator	1		See Table 7.1-3
Satellites Used	14		Number of satellites in view, 00-24
HDOP	0.75		Horizontal Dilution of Precision (meters)
MSL Altitude	140.3	meters	Antenna Altitude above/below mean-sea-level (geoid) (in meters)
Units	M	meters	Units of antenna altitude, meters
Geoidal Separation	17.2	meters	
Units	M	meters	Units of geoidal separation, meters
Age of diff. GNSS data		second	Null fields when DGPS is not used
Diff. Ref. Station ID			Differential reference station ID, 0000-1023
Checksum	*70		Checksum
<CR> <LF>			End of message termination

Table 7.1-3 Position Fix Indicators

Value	Description
-------	-------------

0	Fix not available
1	GNSS fix
2	Differential GNSS fix

● GLL--- Geographic Position – Latitude/Longitude

Table 7.1-4 contains the values for the following example:

\$GNGLL,2503.71465,N,12138.73922,E,062052.000,A,A*45

Table 7.1-4 GLL Data Format

Name	Example	Units	Description
Message ID	\$GNGLL		GLL protocol header
Latitude	2503.71465		ddmm.mmmmm
N/S indicator	N		N=north or S=south
Longitude	12138.73922		dddmm.mmmmm
E/W indicator	E		E=east or W=west
UTC Time	062052.000		hhmmss.sss
Status	A		A=data valid or V=data not valid
Mode	A		N = Invalid, A= Autonomous, D =Differential
Checksum	*45		
<CR> <LF>			End of message termination

● GSA--GNSS DOP and Active Satellites

Table 7.1-5 contains the values for the following example:

\$GPGSA,A,3,193,06,17,02,05,09,12,19,23,,,,,1.11,0.80,0.77*34

\$BDGSA,A,3,08,06,03,01,09,04,02,,,,,1.11,0.80,0.77*19

Table 7.1-5GSA Data Format

Name	Example	Units	Description
Message ID	\$GPGSA		GSA protocol header
Mode 1	A		See Table 7.1-6
Mode 2	3		See Table 7.1-7
ID of satellite used	193		Sv on Channel 1
ID of satellite used	06		Sv on Channel 2
....		
ID of satellite used			Sv on Channel 12
PDOP	1.11		Position Dilution of Precision
HDOP	0.80		Horizontal Dilution of Precision
VDOP	0.77		Vertical Dilution of Precision
Checksum	*34		

<CR> <LF>			End of message termination
-----------	--	--	----------------------------

Table 7.1-6 Mode 1

Value	Description
M	Manual- forced to operate in 2D or 3D mode
A	Automatic-allowed to automatically switch 2D/3D

Table 7.1-7 Mode 2

Value	Description
1	Fix not available
2	2D ¹
3	3D

Note 1: 2D fix hint that the receiver position error meets the 2D level. Maybe under this condition the used satellite number is little more than 4

● GSV---GNSS Satellites in View

Table 7.1-8 contains the values for the following example:

```
$GPGSV,4,1,15,193,69,35,39,6,50,28,41,137,50,134,34,129,50,134,34*73
$GPGSV,4,2,15,17,45,137,41,2,42,326,40,5,42,250,40,128,38,243,36*4B
$GPGSV,4,3,15,9,36,65,42,12,26,285,35,127,12,260,32,19,9,137,35*7D
$GPGSV,4,4,15,23,8,41,35,25,4,316,36,28,,, *4F
$BDGSV,3,1,09,8,75,64,39,6,73,237,38,3,58,205,38,1,53,143,38*56
$BDGSV,3,2,09,9,47,224,38,4,38,118,37,2,35,246,33,5,16,259,31*6C
$BDGSV,3,3,09,10,2,210,21*62
```

Table 7.1-8 GSV Data Format

Name	Example	Units	Description
Message ID	\$GPGSV		GSV protocol header
Total number of messages ¹	4		Range 1 to 6
Message number ¹	1		Range 1 to 6
Satellites in view	215		
Satellite ID ²	193		Channel 1
Elevation	69	degrees	Channel 1 (Range 00 to 90)
Azimuth	35	degrees	Channel 1 (Range 000 to 359)
SNR (C/No)	35	dB-Hz	Channel 1 (Range 00 to 99, null when not tracking)
....		
Satellite ID	129		Channel 4 (Range 01 to 196)
Elevation	50	degrees	Channel 4 (Range 00 to 90)
Azimuth	134	degrees	Channel 4 (Range 000 to 359)
SNR (C/No)	34	dB-Hz	Channel 4 (Range 00 to 99, null when not tracking)

Checksum	*73		
<CR> <LF>			End of message termination

Note 1: Depending on the number of satellites tracked multiple messages of GSV data may be required.

2: GPS ID: 01~32, SBAS ID: 120~140, QZSS ID: 193~196, BEIDOU ID: 01~32

● RMC---Recommended Minimum Specific GNSS Data

Table 7.1-9 contains the values for the following example:

\$GNRMC,033900.000,A,2503.71632,N,12138.74601,E,0.000,0.50,281015,0.0,E,A*20

Table 7.1-9 RMC Data Format

Name	Example	Units	Description
Message ID	\$GNRMC		RMC protocol header
UTC Time	033900.000		hhmmss.sss
Status	A		A=data valid or V=data not valid
Latitude	2503.71632		ddmm.mmmmm
N/S Indicator	N		N=north or S=south
Longitude	12138.74601		dddmm.mmmmm
E/W Indicator	E		E=east or W=west
Speed over ground	0.000	knots	True
Course over ground	0.50	degrees	
Date	281015		ddmmyy
Magnetic variation	0.0	degrees	
Variation sense	E		E=east or W=west
Mode	A		N=Invalid A=autonomous, D=Differential.
Checksum	*20		
<CR> <LF>			End of message termination

● VTG---Course Over Ground and Ground Speed

Table 7.1-10 contains the values for the following example:

\$GNVTG,0.05,T,0.00,M,0.000,N,0.010,K,A*39

Table 7.1-10 VTG Data Format

Name	Example	Units	Description
Message ID	\$GNVTG		VTG protocol header
Course over ground	0.50	degrees	Measured heading
Reference	T		True
Course over ground	0.00	degrees	Measured heading
Reference	M		Magnetic

Speed over ground	0.000	knots	Measured speed
Units	N		Knots
Speed over ground	0.010	km/hr	Measured speed
Units	K		Kilometer per hour
Mode	A		N =Invalid A=autonomous, D=Differential.
Checksum	*39		
<CR> <LF>			End of message termination

● ZDA--- Time & Date

Table 7.1-11 contains the values for the following example:

\$GNZDA,033900.000,28,10,2015,*,*4C

Table 7.1-11 ZDA Data Format

Name	Example	Units	Description
Message ID	\$GNZDA		ZDA protocol header
UTC Time	033900.000		hhmmss.sss
Day	28		dd (01 to 31)
Month	10		mm (01 to 12)
Year	2015		yyyy (1980 to 2025)
Local zone hours		hour	
Local zone minutes		minute	
Checksum	*4C	4C	
<CR> <LF>			End of message termination

7.2 ALLYSTAR Proprietary Binary Packet Set

The following table shows the most common use proprietary command sets

Table 7.2-1 The table below summarizes the set of proprietary command sets for the HD-1612-BA

Command descriptions	Software command ²
Perform a Cold start	F1 D9 06 40 01 00 01 48 22
Perform a Warm start	F1 D9 06 40 01 00 02 49 23
Perform a Hot start	F1 D9 06 40 01 00 03 4A 24
Perform a Factory reset :	F1 D9 06 09 08 00 02 00 00 00 FF FF FF FF 15 01
UART configures as 115200bps	F1 D9 06 00 08 00 00 00 00 00 C2 01 00 D1 E0
UART configures as 9600bps	F1 D9 06 00 08 00 00 00 00 00 80 25 00 00 B3 07
Enable ZDA message	F1 D9 06 01 03 00 F0 07 01 02 1E
Disable ZDA message	F1 D9 06 01 03 00 F0 07 00 01 1D
Navigate with GPS only	F1 D9 06 0C 04 00 01 00 00 00 17 A0
Navigate with BEIDOU system only	F1 D9 06 0C 04 00 04 00 00 00 1A AC
Navigate with GPS+BEIDOU system	F1 D9 06 0C 04 00 05 00 00 00 1B B0
Switch to Vehicle mode	F1 D9 06 0F 02 00 96 00 AD A3
Switch to Pedestrian mode	F1 D9 06 0F 02 00 00 00 17 77
Query firmware version ¹	F1 D9 0A 05 00 00 0F 37

Note

1: Firmware version will show as Hex mode too.

2: Add **0D 0A** at the end of command.

8 Recommended soldering reflow profile

The module belongs to RoHS device. The maximum of reflow temperature, real on top of PCB, is not over 240 Celsius.

Lead-free Processes

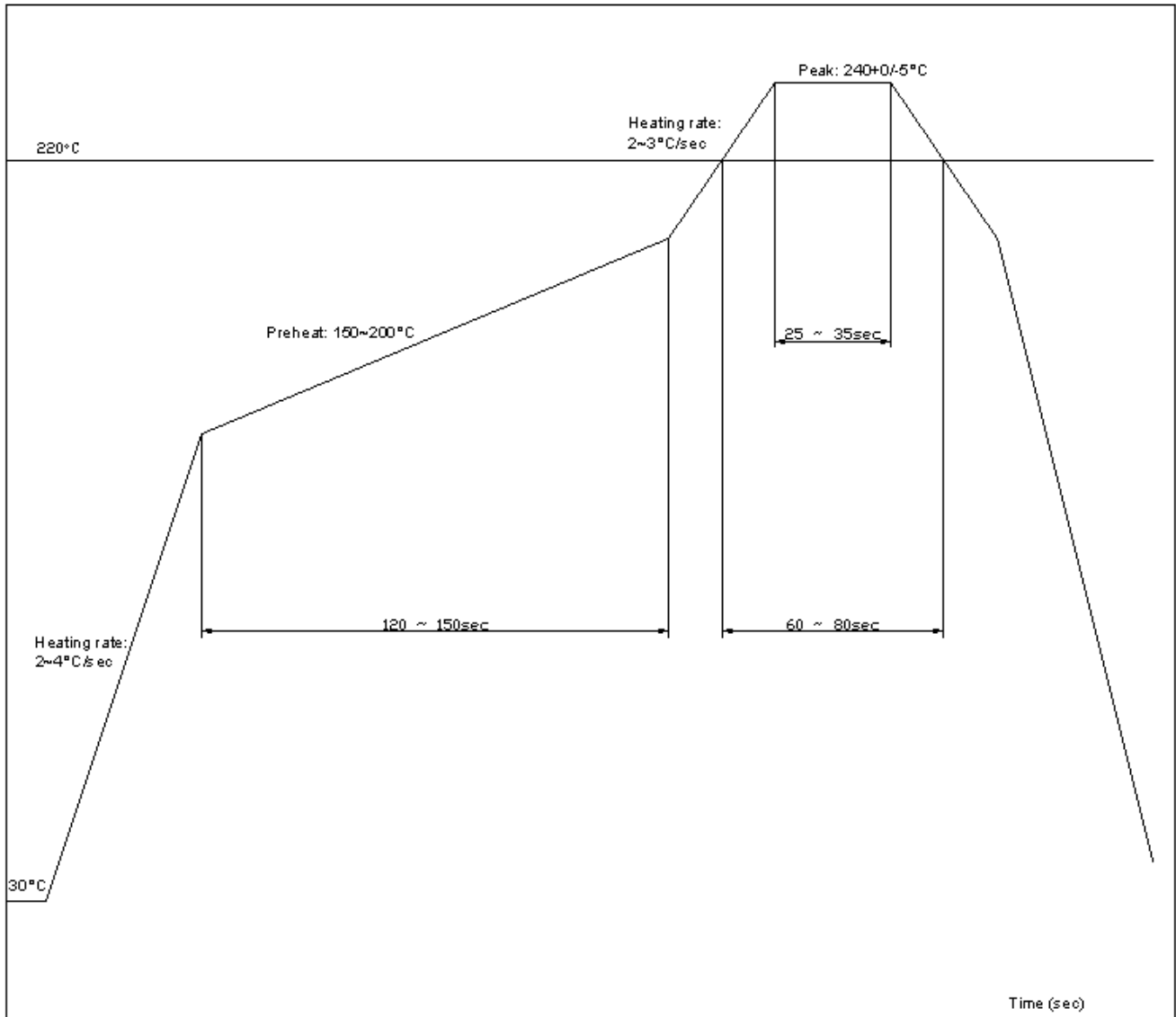

Lead-Free Solder Paste (Sn 96.5-Ag 3.0-Cu 0.5)

Cycle Interval: 300 sec

Note:

The HD-1612-BA module should be soldered on the topside in the soldering process to prevent from falling down.

9 Reel packing information

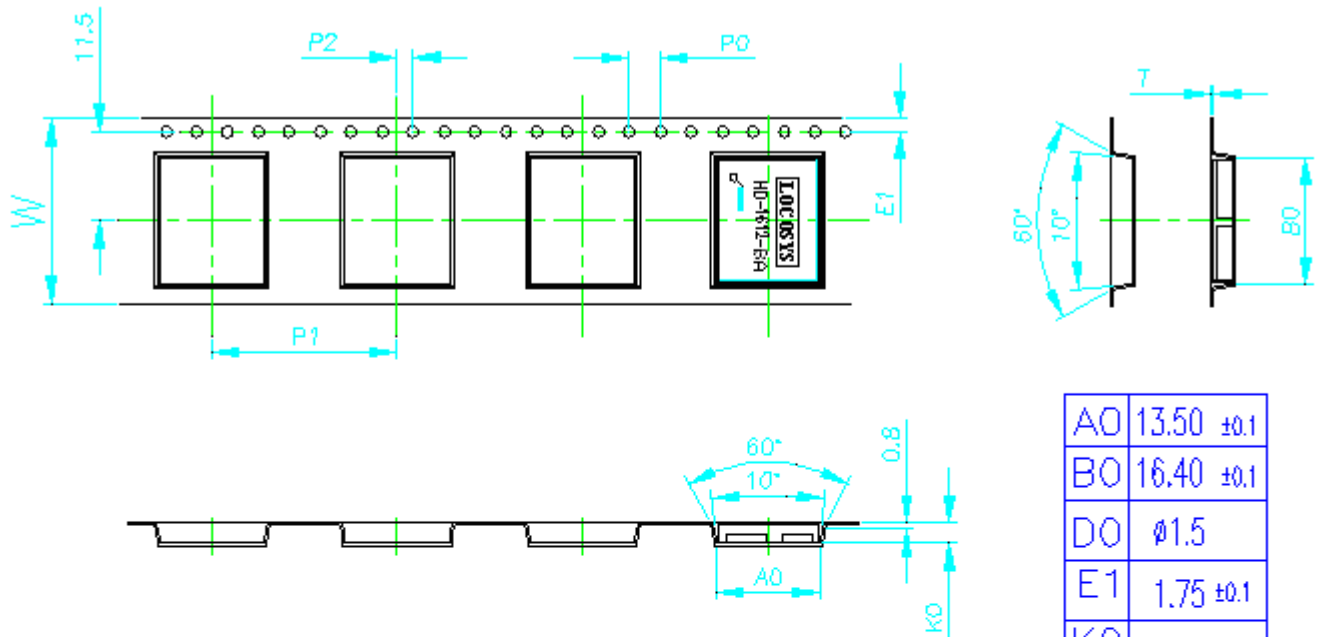

A0	13.50 ±0.1
B0	16.40 ±0.1
D0	∅1.5
E1	1.75 ±0.1
K0	2.70 ±0.1
P0	4.0 ±0.1
P1	24.00 ±0.1
P2	2.0 ±0.10
T	0.3 ±0.10
W	24.0 ±0.30

1. 10 sprocket hole pitch cumulative tolerance ±0.2
2. Camber not to exceed 1mm in 100mm
3. A0 and B0 measured on a plane 0.3mm above the bottom of the pocket
4. K0 measured from a plane on the inside bottom of the pocket to the top surface of the carrier .
5. pocket position relative to sprocket hole measured as true position of pocket,not pocket hole.
6. Component load per 13"reel: 1000 pcs
7. Packing length per 22"reel: 75 M

10 Packing and Handling

GNSS modules, like any other SMD devices, are sensitive to moisture, electrostatic discharge, and temperature. By following the description sketched in the document for LOCOSYS GNSS module storage and handling, it is possible to reduce the chances of them being damaged during production.

10.1 Packing

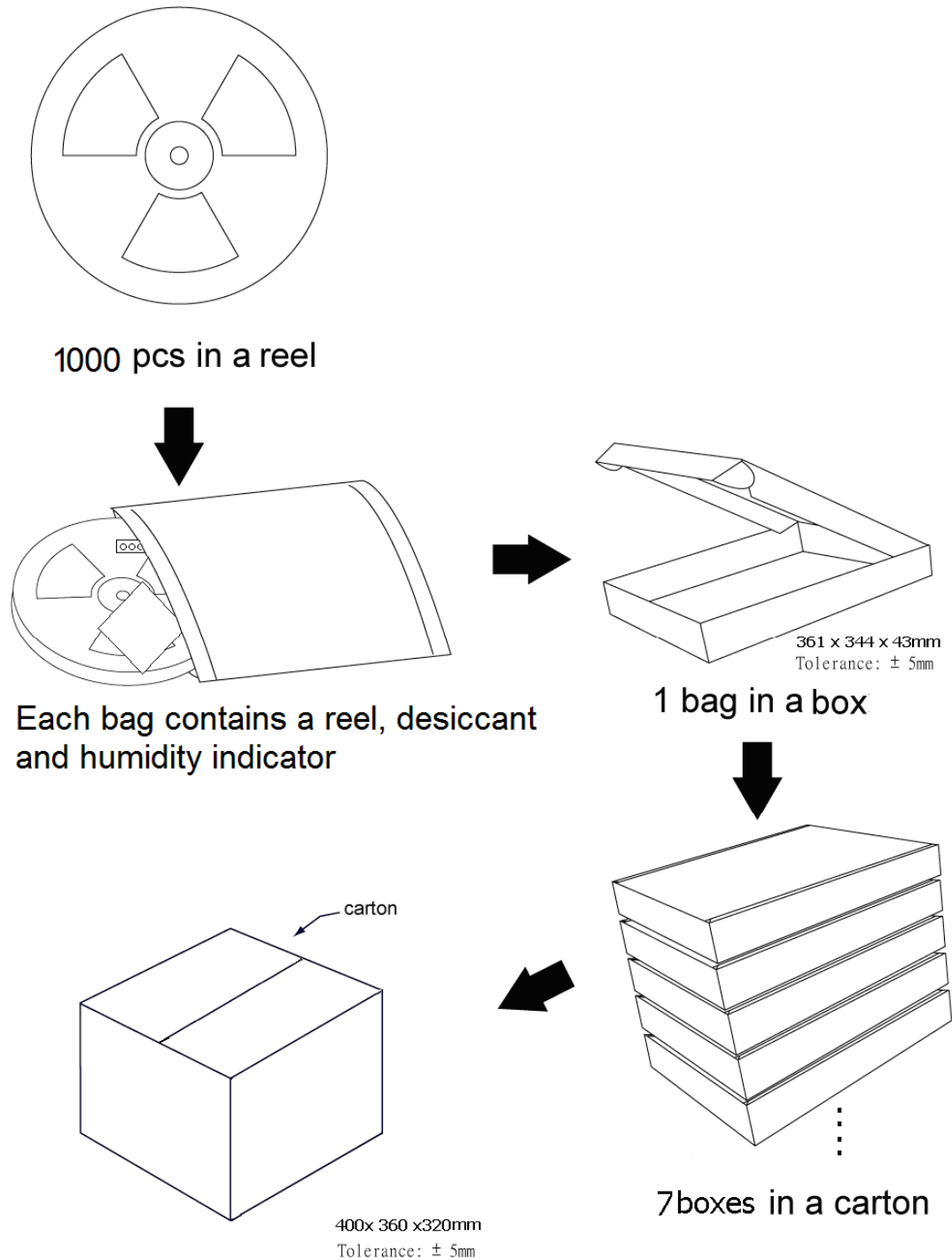

10.2 Moisture Sensitivity

The module belongs to moisture sensitive device (IPC/JEDEC J-STD-020C Level III). If it is not used by then, we strong recommended storing the GNSS modules in dry places such as dry cabinet. The approximate shelf life for LOCOSYS GNSS modules packages is 6 months from the bag seal date, when store in a non-condensing storage environment (<30°C/60% RH)

10.3 ESD Handling



Please carefully follow the following precautions to prevent severe damage to GNSS modules.

LOCOSYS GNSS modules are sensitive to electrostatic discharges, and thus are Electrostatic Sensitive Devices (ESD). Careful handling of the GNSS modules and in particular RFIN pin must follow the standard ESD safety protections:

- Unless there is a galvanic coupling between the local GND and the PCB GND, then the first point of contact when handling the PCB shall always be between the local GND and PCB GND.
- Before working with RFIN pin, please make sure the GND is connected
- When working with RFIN pin, do not contact any charges capacitors or materials that can easily develop or store charges such as patch antenna, coax cable, soldering iron.
When soldering RFIN pin, please make sure to use an ESD safe soldering iron (tip).

Document change list

Revision 1.0

- First release on October 18, 2016.