

Product name	Description	Version
ST-1612i-B	Multi-constellation GNSS module (GPS, BEIDOU, GALILEO, QZSS)	1.2



1 Introduction

LOCOSYS ST-1612i-B module can simultaneously acquire and track multiple satellite constellations that include GPS, BEIDOU, GALILEO and QZSS. It features high sensitivity, low power and small form factor. It can provide you with superior sensitivity and performance even in urban canyon and dense foliage environment.

2 Features

- Support GPS, BEIDOU, GALILEO and QZSS
- Capable of SBAS (WAAS, EGNOS, MSAS, GAGAN)
- 48 tracking channels and 2 fast acquisition channels
- IATF 16949 quality control
- Small form factor 16 x 12.2 x 2.4 mm
- SMD type, RoHS compliant

3 Application

- Personal positioning and navigation
- Automotive navigation
- Marine navigation

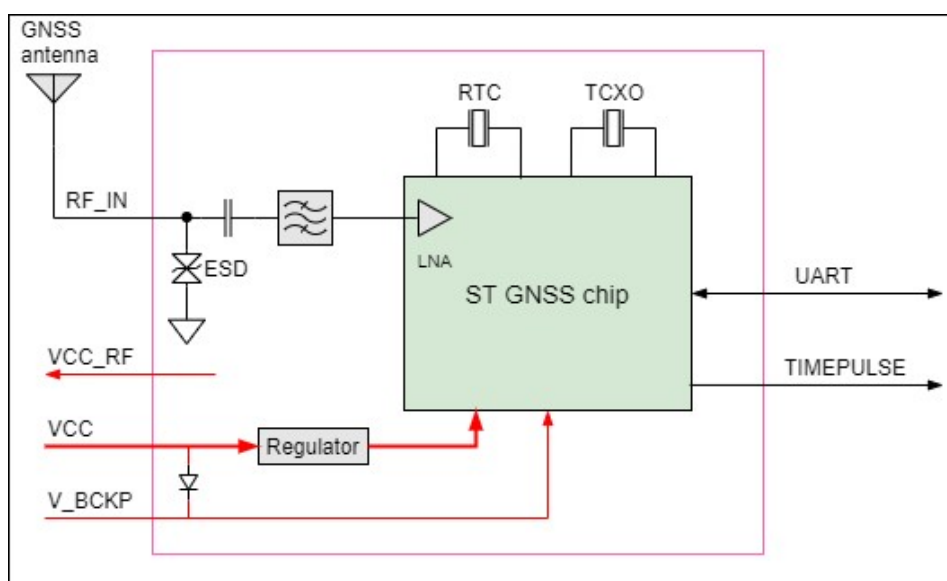

Fig 3-1 System block diagram.

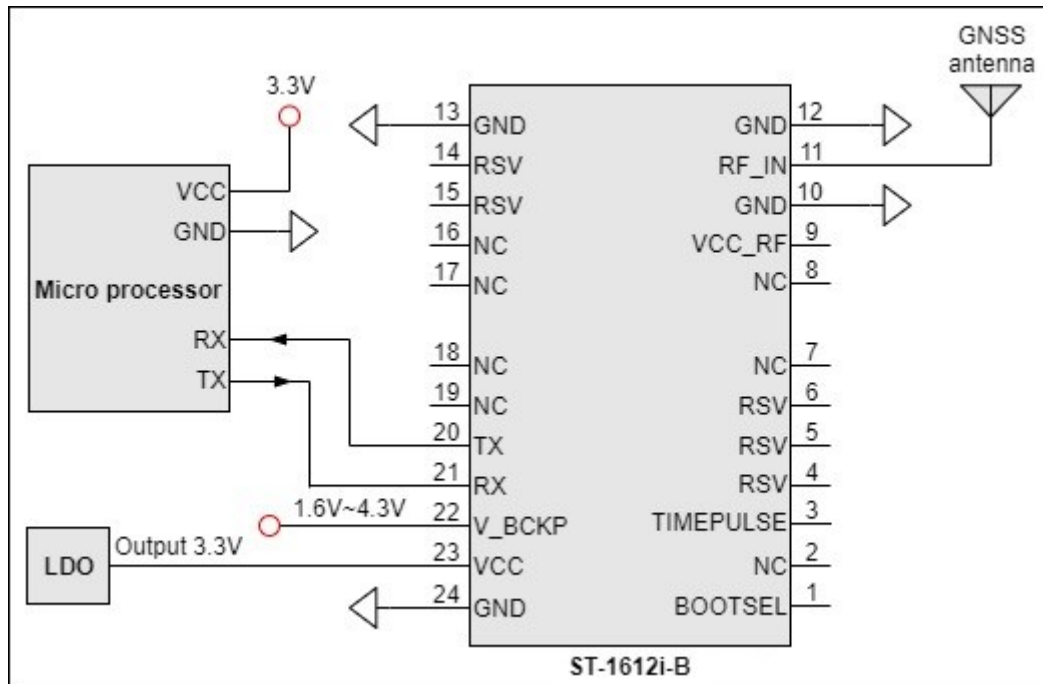

Fig 3-2 Typical application circuit that uses a passive antenna.

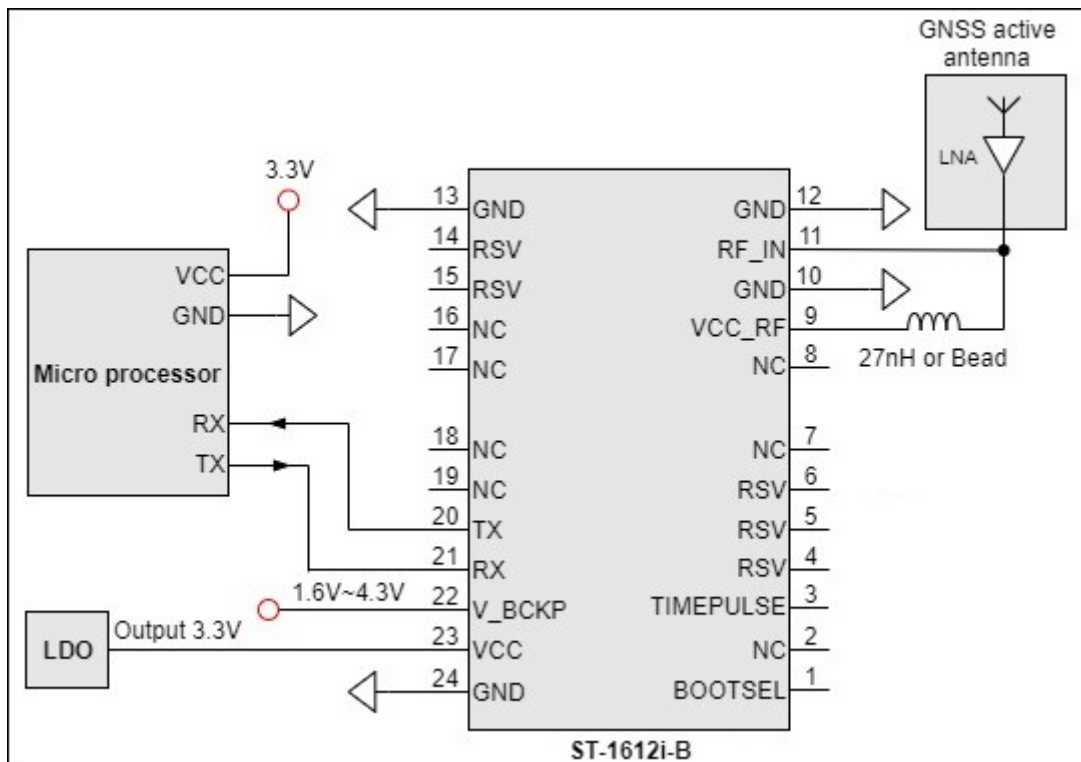

Fig 3-3 Typical application circuit that uses an active antenna.

4 GNSS receiver

Chip	Teseo III series	
Frequency	GPS: L1C/A (1575.42MHz) BEIDOU: B1 (1561.098MHz) GALILEO: E1B/C (1575.42MHz) QZSS: L1C/A (1575.42MHz)	
Channels	Support 48 channels	
Update rate	1Hz default, up to 10Hz.	
Sensitivity	Tracking	up to -161dBm (with external LNA)
	Cold start	up to -146.5dBm (with external LNA)
Acquisition Time	Cold Start (Open Sky)	29s (typical)
	Hot Start (Open Sky)	< 2s (typical)
Position Accuracy	Autonomous	1.8m CEP
	SBAS	1.5m CEP (depends on accuracy of correction data).
Max. Altitude	< 18,000 m	
Max. Velocity	< 515 m/s	
Protocol Support	NMEA 0183 ver. 3.01	38400 bps ⁽¹⁾ , 8 data bits, no parity, 1 stop bits (default) 1Hz: GGA, GLL, GSA, GSV, RMC, VTG

Note 1: Both baud rate and output message rate are configurable to be factory default.

5 Software interface

5.1 NMEA output message

Table 5.1-1 NMEA output message

NMEA record	Description
GGA	Global positioning system fixed data
GLL	Geographic position – latitude/longitude
GSA	GNSS DOP and active satellites
GSV	GNSS satellites in view
RMC	Recommended minimum specific GNSS data
VTG	Course over ground and ground speed

● GGA--- Global Positioning System Fixed Data

Table 5.1-2 contains the values for the following example:

\$GPGGA,051951.000,2503.71325,N,12138.74397,E,2,30,0.6,113.69,M,15.3,M,,*69

Table 5.1-2 GGA Data Format

Name	Example	Units	Description
Message ID	\$GPGGA		GGA protocol header

UTC Time	051951.000		hhmmss.sss
Latitude	2503.71325		ddmm.mmmmm
N/S indicator	N		N=north or S=south
Longitude	12138.74397		dddmm.mmmmm
E/W Indicator	E		E=east or W=west
Position Fix Indicator	2		See Table 5.1-3
Satellites Used	30		Satellites in use
HDOP	0.6		Horizontal Dilution of Precision
MSL Altitude	113.69	meters	Height above mean sea level, max: 100000.0 m
Units	M	meters	Unit for MSL Altitude
Geoid Separation	15.3	meters	Geoidal separation measure in “M” = meters
Units	M	meters	
Age of Diff. Corr.		second	Null. Not supported.
Diff. Ref. Station ID			Null. Not supported.
Checksum	*69		
<CR> <LF>			End of message termination

Table 5.1-3 Position Fix Indicators

Value	Description
0	Fix not available or invalid
1	GPS SPS Mode, fix valid
2	Differential GPS, SPS Mode, fix valid
3-5	Not supported
6	Dead Reckoning Mode, fix valid

- **GLL--- Geographic Position – Latitude/Longitude**

Table 5.1-4 contains the values for the following example:

\$GPGLL,2503.71310,N,12138.74601,E,074606.000,A,D*52

Table 5.1-4 GLL Data Format

Name	Example	Units	Description
Message ID	\$GPGLL		GLL protocol header
Latitude	2503.71310		ddmm.mmmmm
N/S indicator	N		Latitude Direction: North or South
Longitude	12138.74601		dddmm.mmmmm
E/W indicator	E		Longitude Direction: East or West
UTC Time	074606.000		hhmmss.sss
Status	A		Validity of Data; A=data valid or V=data invalid

Mode	D		A = Autonomous mode, D = Differential mode, E = Estimated (Dead Reckoning) Mode, N=Data invalid,
Checksum	*52		
<CR> <LF>			End of message termination

● **GSA---GNSS DOP and Active Satellites**

Table 5.1-5 contains the values for the following example:

```
$GNGSA,A,3,09,19,02,05,06,17,12,,,,,1.2,0.6,1.0*2D
$GNGSA,A,3,195,199,193,,,,,,,1.2,0.6,1.0*1F
$GNGSA,A,3,303,305,311,309,,,,,,,0.9,0.5,0.7*28
$GNGSA,A,3,142,143,160,148,150,149,147,169,162,153,159,170,0.9,0.5,0.7*21
```

Table 5.1-5 GSA Data Format

Name	Example	Units	Description
Message ID	\$GNGSA		GSA protocol header
Mode 1	A		See Table 5.1-6
Mode 2	3		See Table 5.1-7
ID of satellite used	09		Sv on Channel 1
ID of satellite used	19		Sv on Channel 2
....		
ID of satellite used			Sv on Channel 12
PDOP	1.2		Position Dilution of Precision
HDOP	0.6		Horizontal Dilution of Precision
VDOP	1.0		Vertical Dilution of Precision
Checksum	*23		
<CR> <LF>			End of message termination

Table 5.1-6 Mode 1

Value	Description
M	Manual- forced to operate in 2D or 3D mode
A	Automatic-allowed to automatically switch 2D/3D

Table 5.1-7 Mode 2

Value	Description
1	Fix not available
2	2D
3	3D

● **GSV---GNSS Satellites in View**

Table 5.1-8 contains the values for the following example:

```
$GPGSV,3,1,10,19,53,141,47,06,48,048,46,05,47,266,46,02,45,335,47*74
$GPGSV,3,2,10,17,37,145,47,09,29,052,41,12,26,272,41,13,15,190,*73
$GPGSV,3,3,10,42,54,141,41,50,51,134,42,,,,,,,,*7F
$QZGSV,1,1,04,193,74,061,46,195,66,145,47,199,60,167,41,194,10,162,40*6C
$GAGSV,1,1,04,309,63,051,46,305,59,203,45,311,37,102,40,303,08,214,36*65
$BDGSV,3,1,12,169,82,344,50,159,60,258,49,143,60,207,46,160,56,022,51*65
$BDGSV,3,2,12,148,53,010,46,153,45,333,46,170,39,136,47,142,40,243,42*6E
$BDGSV,3,3,12,149,25,192,41,150,25,220,39,147,18,194,36,162,11,234,37*60
```

Table 5.1-8 GSV Data Format

Name	Example	Units	Description
Message ID	\$GPGSV		GSV protocol header
Total number of messages ¹	3		Range 1 to 8
Message number ¹	1		Range 1 to 8
Satellites in view	10		
Satellite ID	19		Channel 1 (Range 01 to 196)
Elevation	53	degrees	Channel 1 (Range 00 to 90)
Azimuth	141	degrees	Channel 1 (Range 000 to 359)
SNR (C/No)	47	dB-Hz	Channel 1 (Range 00 to 99, null when not tracking)
....			
Satellite ID	02		Channel 4 (Range 01 to 32)
Elevation	45	degrees	Channel 4 (Range 00 to 90)
Azimuth	335	degrees	Channel 4 (Range 000 to 359)
SNR (C/No)	47	dB-Hz	Channel 4 (Range 00 to 99, null when not tracking)
Checksum	*74		
<CR> <LF>			End of message termination

Note 1: Depending on the number of satellites tracked multiple messages of GSV data may be required.

● RMC---Recommended Minimum Specific GNSS Data

Table 5.1-9 contains the values for the following example:

```
$GPRMC,051951.000,A,2503.71325,N,12138.74397,E,0.0,0.0,260819,,,D*67
```

Table 5.1-9 RMC Data Format

Name	Example	Units	Description
Message ID	\$GPRMC		RMC protocol header
UTC Time	051951.000		hhmmss.sss
Status	A		A=data valid or V=data not valid

Latitude	2503.71325		ddmm.mmmmm
N/S Indicator	N		N=north or S=south
Longitude	12138.74397		dddmm.mmmmm
E/W Indicator	E		E=east or W=west
Speed over ground	0.0	knots	True
Course over ground	0.0	degrees	
Date	260819		ddmmyy
Magnetic variation		degrees	
Variation sense			E=east or W=west (Not shown)
Mode	D		A=autonomous, D=DGPS, E=DR, N=Data not valid, R=Coarse Position, S=Simulator
Checksum	*67		
<CR> <LF>			End of message termination

- **VTG---Course Over Ground and Ground Speed**

Table 5.1-10 contains the values for the following example:

\$GPVTG,0.0,T,,M,0.0,N,0.1,K,D*09

Table 5.1-10 VTG Data Format

Name	Example	Units	Description
Message ID	\$GPVTG		VTG protocol header
Course over ground	0.0	degrees	Reference to “true” earth poles
Reference	T		Indicates “terrestrial”
Course over ground		degrees	Reference to “magnetic” earth poles
Reference	M		Indicates “Magnetic”
Speed over ground	0.0	knots	Speed over ground in knots
Units	N		Indicates “Knots”
Speed over ground	0.1	km/h	Speed over ground in kilometers per hour
Units	K		Indicates “Kilometers per hour”
Mode	D		A = Autonomous mode, D = Differential mode, E = Estimated (Dead Reckoning)mode
Checksum	*09		
<CR> <LF>			End of message termination

5.2 Proprietary NMEA commands

Table 5.2-1 Proprietary command sets

Software command	Command descriptions
\$PSTMCOLD<CR><LF>	Perform a Cold start
\$PSTMWARM<CR><LF>	Perform a Warm start
\$PSTMHOT<CR><LF>	Perform a Hot start
\$PSTMSRR<CR><LF>	Executes a system reset. The GNSS firmware is rebooted.
\$PSTMRESTOREPAR<CR><LF>	Restore System Parameters (Factory Settings)

- **\$PSTMCOLD**

Perform a COLD start.

Synopsis:

\$PSTMCOLD,<Mask><CR><LF>

Table 5.2-2 \$PSTMCOLD Data format

Parameter	Format	Description
Mask	Integer	Optional parameter to invalidate time, position, ephemeris and almanac: 0x1-clear almanac 0x2-clear ephemeris 0x4-clear position 0x8-clear time

Note: If Mask parameter is not used, default is 0xE (clear ephemeris, time and position).

Example:

\$PSTMCOLD,6

- **\$PSTMWARM**

Perform a WARM start.

Synopsis:

\$PSTMWARM<CR><LF>

Example:

```
$PSTMWARM
```

● \$PSTMHOT

Perform a HOT start.

Synopsis:

```
$PSTMHOT<CR><LF>
```

Example:

```
$PSTMHOT
```

● \$PSTMSRR

Executes a system reset. The GNSS firmware is rebooted.

Synopsis:

```
$PSTMSRR<CR><LF>
```

Example:

```
$PSTMSRR
```

● \$PSTMRESTOREPAR

Restore the factory setting parameters. The configuration data block stored in NVM, if present, will be invalidated. Any changed parameter will be lost.

Synopsis:

```
$PSTMRESTOREPAR<CR><LF>
```

Example:

```
$PSTMRESTOREPAR
```

6 Pin assignment and descriptions



Table 6-1 Pin descriptions

Pin #	Name	Type	Description	Note
1	BOOTSEL		Boot mode selection. High: firmware update. Leave unconnected for normal operation.	
2	NC		Not connected	
3	TIMEPULSE	O	Time pulse (1PPS, default 100 ms pulse/sec) Leave unconnected if not used. It must be at low level during power-on reset in order for the module to work.	
4	RSV		Reserved pin. Leave unconnected.	
5	RSV		Reserved pin. Leave unconnected.	
6	RSV		Reserved pin. Leave unconnected.	
7	NC		Not connected	
8	NC		Not connected	
9	VCC_RF	O	Output voltage for active antenna	1
10	GND	P	Ground	
11	RF_IN	I	GNSS RF signal input	
12	GND	P	Ground	
13	GND	P	Ground	

14	RSV		Reserved pin. Leave unconnected.	
15	RSV		Reserved pin. Leave unconnected.	
16	NC		Not connected	
17	NC		Not connected	
18	NC		Not connected	
19	NC		Not connected	
20	TX	O	Serial output (Default NMEA)	
21	RX	I	Serial input (Default NMEA)	
22	V_BCKP	I	Backup battery input	2
23	VCC	I	DC supply input	
24	GND	P	Ground	

Note:

1. VCC_RF does not have short circuit protection.
2. V_BCKP needs to be powered 1ms earlier than VCC. If V_BCKP and VCC are tied and powered together, the voltage rise time must be between 2ms and 50ms.

7 DC & Temperature characteristics

7.1 Absolute maximum ratings

Parameter	Symbol	Ratings	Units
DC Supply Input Voltage	VCCabs.	3.6	V
Backup Battery Input Voltage	V_BCKPabs.	4.3	V
Operating Temperature Range	To _{pr_} abs.	-40 ~ 85	°C
Storage Temperature Range	T _{stg_} abs.	-40 ~ 85	°C

7.2 DC Electrical characteristics

Parameter	Symbol	Conditions	Min.	Typ.	Max.	Units
DC Supply Input Voltage	VCC		3.0	3.3	3.6	V
Backup Battery Input Voltage	V_BCKP		1.6		4.3	V
VCC_RF Output Voltage	VCC_RF			VCC		V
Supply Current	I _{ss}	VCC = 3.3V, w/o active antenna, Peak Acquisition Tracking		68 73 ⁽¹⁾	180	mA mA mA
Backup Battery Current	I _{bat}	VCC = 0V		9		uA
VCC_RF Output Current	I _{out}	VIN = 3.3V			25	mA
High Level Input Voltage	V _{IH}		2.0		3.6	V
Low Level Input Voltage	V _{IL}		-0.3		0.8	V
High Level Output Voltage	V _{OH}		2.6			V
Low Level Output Voltage	V _{OL}				0.4	V

Note 1. Measured for 12 hours when position fix (1Hz) is available and input voltage is 3.3V with UART interface.

7.3 Temperature characteristics

Parameter	Symbol	Min.	Typ.	Max.	Units
Operating Temperature	To _{pr}	-40	-	85	°C
Storage Temperature	T _{stg}	-40	25	85	°C

8 Mechanical specification

8.1 Outline dimensions

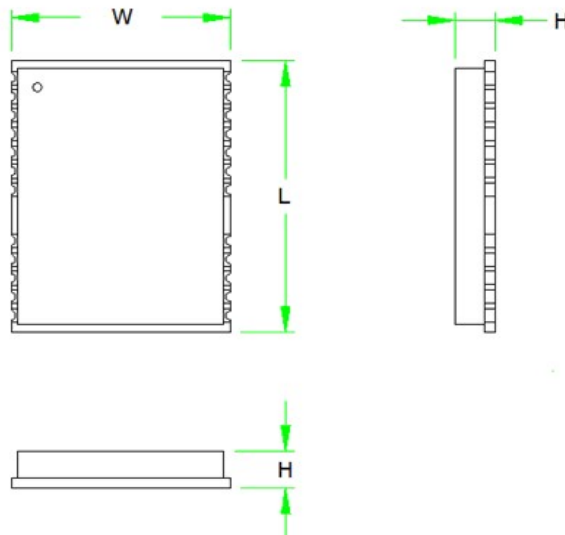

Symbol	Min. (mm)	Typ. (mm)	Max. (mm)
W	12.1	12.2	12.3
L	15.7	16.0	16.4
H	2.2	2.4	2.6

8.2 Recommended land pattern dimensions

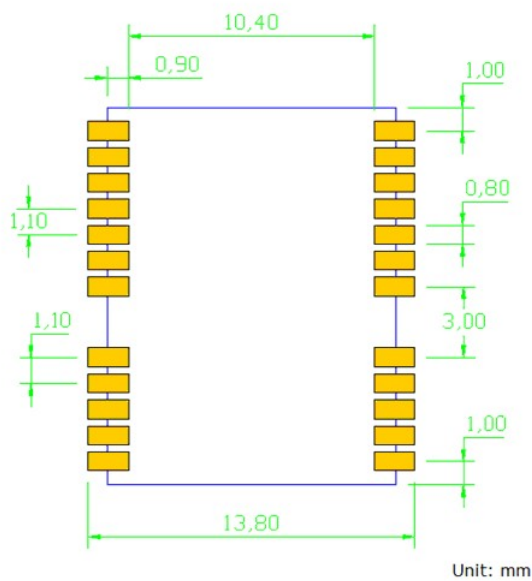

Note: The recommended land pattern dimensions are shown for reference only, as actual layout may vary for different applications.

9 Product handling

9.1 ESD precaution

GNSS modules are electrostatic sensitive devices. Handling the modules without proper ESD protection may result in severe damage to them. ESD protection must be implemented throughout the processing, handling and even when the modules are being returned for repair.

9.2 Packaging

The modules are sealed in a moisture barrier ESD bag with the appropriate units of desiccant and a humidity indicator card. It should not be opened until the modules are ready to be soldered onto the application.

9.2.1 Tape and reel packaging

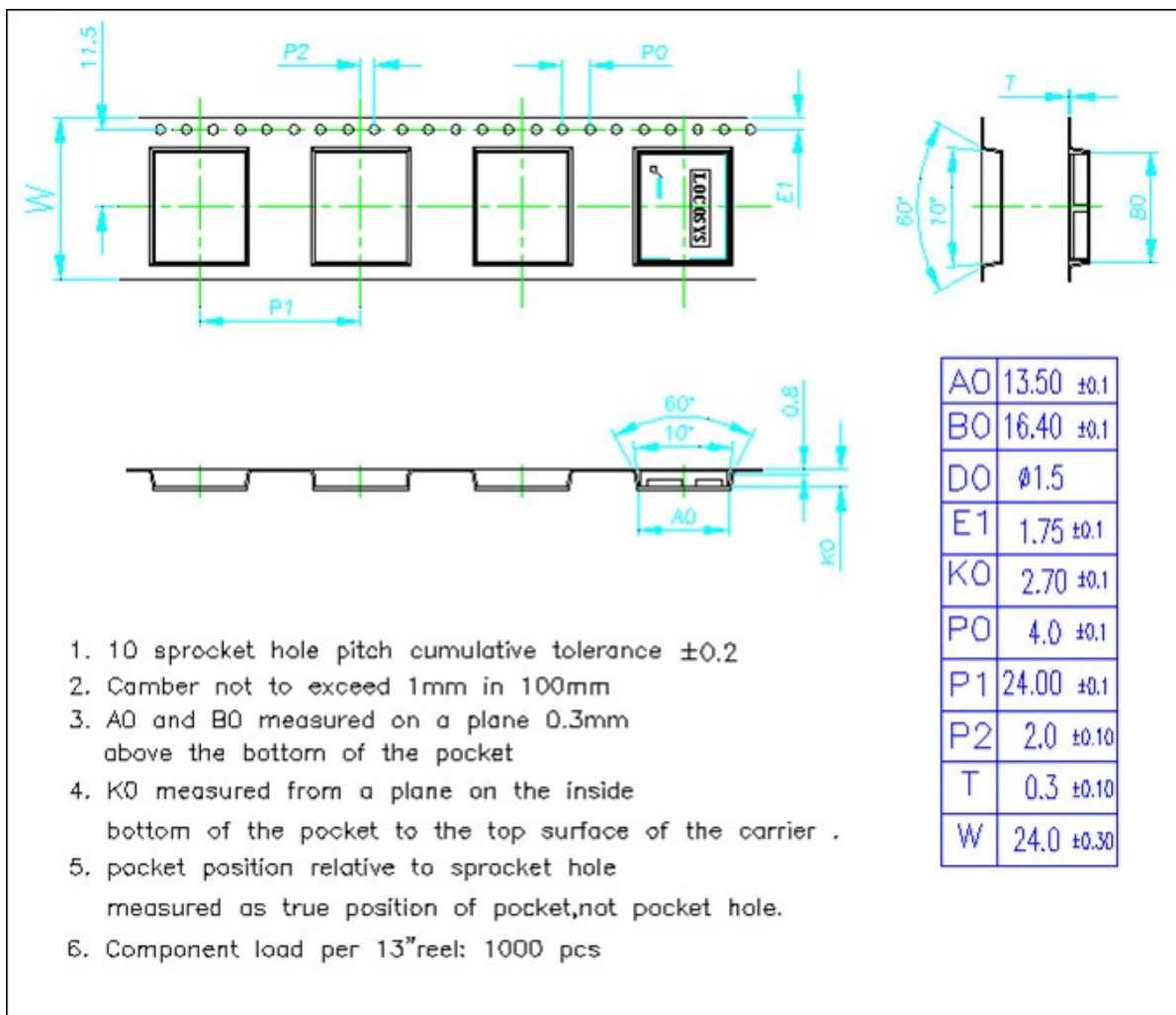

9.2.2 Box packaging

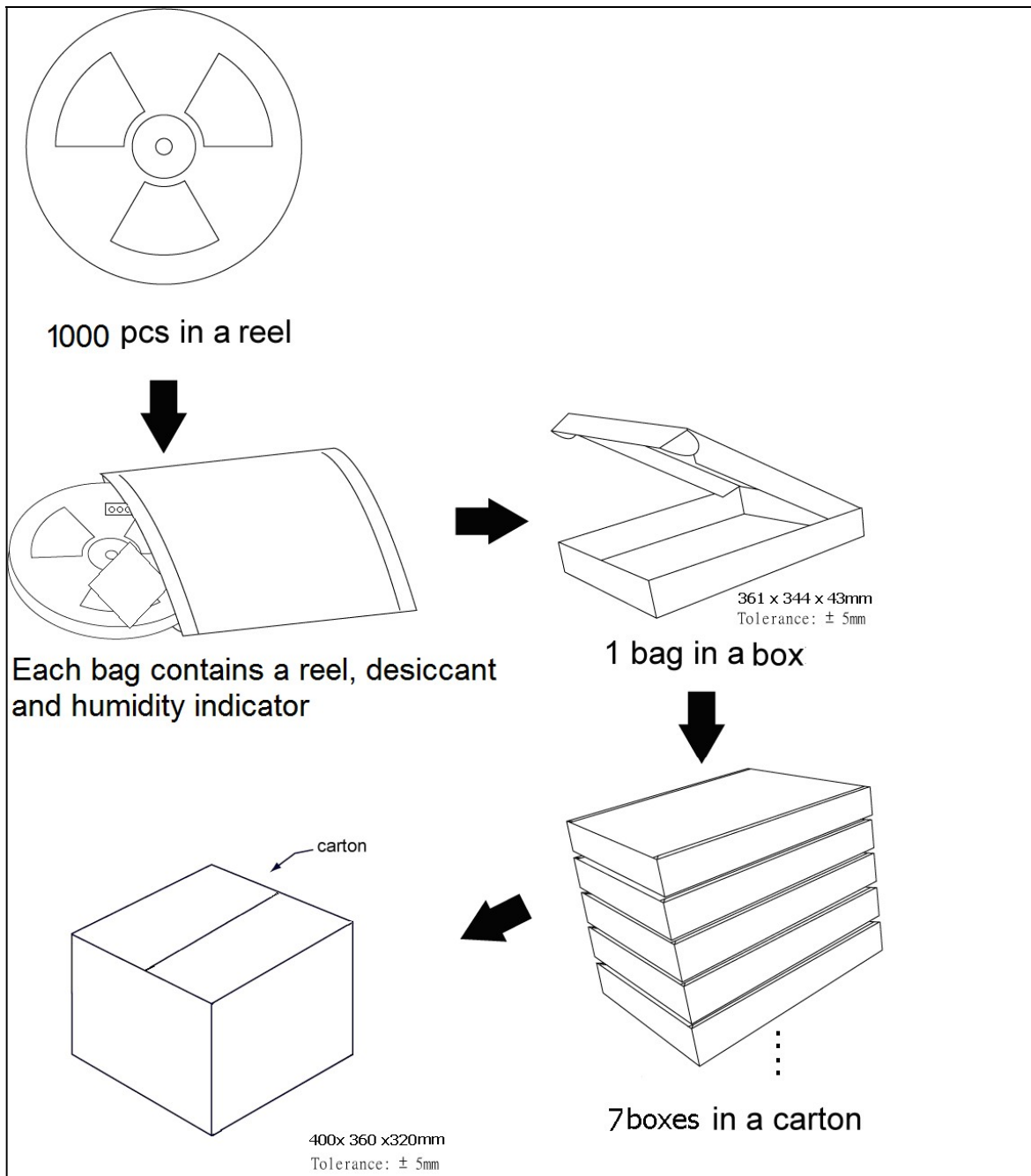

9.3 Moisture sensitivity level

The moisture sensitivity level of the module is 3. After the sealed bag is opened, modules should be mounted within 168 hours at factory conditions of $\leq 30^{\circ}\text{C}$ and 60% RH or stored at $\leq 20\%$ RH.

The modules require baking before mounting if above conditions are not met. If baking is required, the modules without the tape and reel may be baked for:

- 192 hours at $40^{\circ}\text{C} + 5^{\circ}\text{C} / -0^{\circ}\text{C}$ and $< 5\%$ RH
- 24 hours at $125^{\circ}\text{C} + 5^{\circ}\text{C} / -0^{\circ}\text{C}$

9.4 Reflow soldering

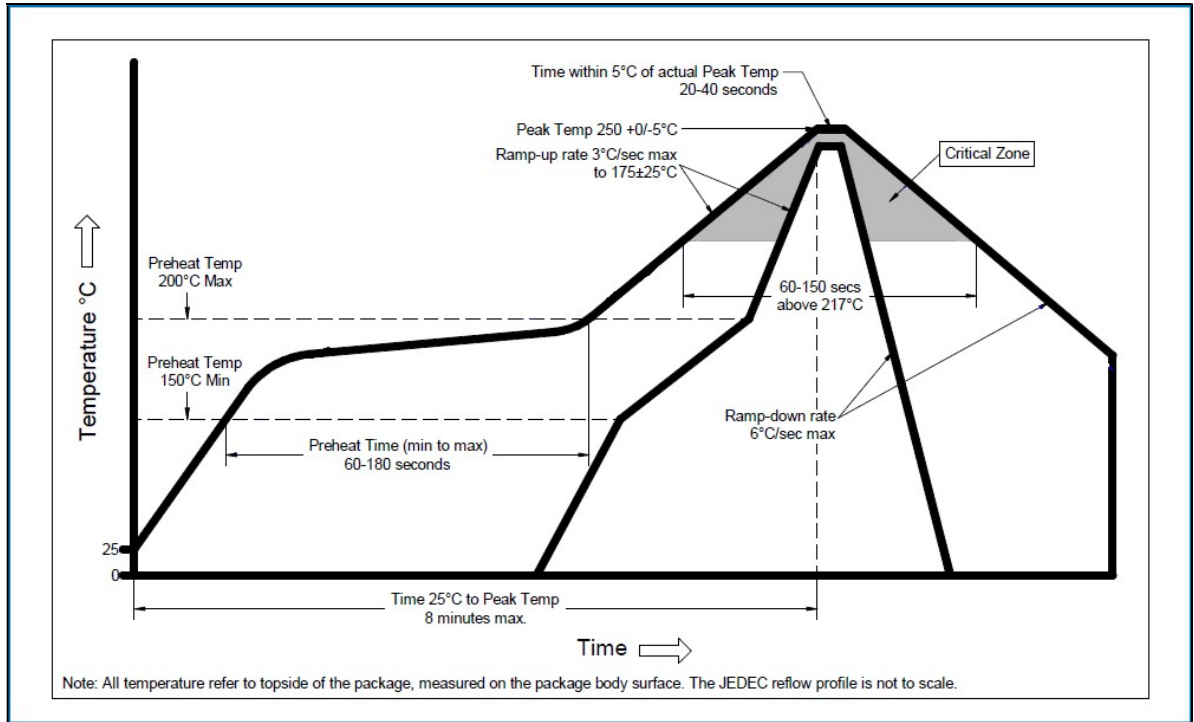

Note the module mounted to the top side (first reflow side) may fall off during reflow soldering of the bottom side.

10 Product marking and ordering information

10.1 Product marking

The marking of the module is engraved on the metal shielding that has product information, such as LOCOSYS logo, product name and manufacturing date.

10.2 Ordering information

Product name	Description	Remark
ST-1612i-B	Multi-constellation GNSS module	GPS, BEIDOU, GALILEO, QZSS

Document change list

Revision 1.0

- First release on September 18, 2020

Revision 1.1 (November 4, 2020)

- Added the note of V_BCKP pin in section 6.

Revision 1.2 (September 22, 2023)

- Added the description to pin 3 (TIMEPULSE) in section 6.