

Product name	Description	Version
S4-1513	Datasheet of S4-1513 GPS module	1.1



1 Introduction

LOCOSYS S4-1513 GPS module features high sensitivity, low power and ultra small form factor. This GPS module is powered by SiRF Star IV, it can provide you with superior sensitivity and performance even in urban canyon and dense foliage environment. With SiRF CGEE (Client Generated Extended Ephemeris) technology, it predicts satellite positions for up to 3 days and delivers CGEE-start time of less than 15 seconds under most conditions, without any network assistance. Besides, MicroPower Mode allows GPS module to stay in a hot-start condition nearly continuously while consuming very little power.

2 Features

- SiRF Star IV high sensitivity solution
- Support 48-channel GPS
- Fast TTFF at low signal level
- Capable of SBAS (WAAS, EGNOS, MSAS, GAGAN)
- Up to 5 Hz update rate
- Built-in active jammer remover to track up to 8 CW jammers
- Embedded free CGEE technology to get faster location fix
- Micro Power Mode
- MEMS support
- SBAS ranging
- Built-in LNA and SAW filter
- Small form factor 15 x 13 x 2.2 mm
- SMD type with stamp holes; RoHS compliant

3 Application

- Personal positioning and navigation
- Automotive navigation
- Marine navigation

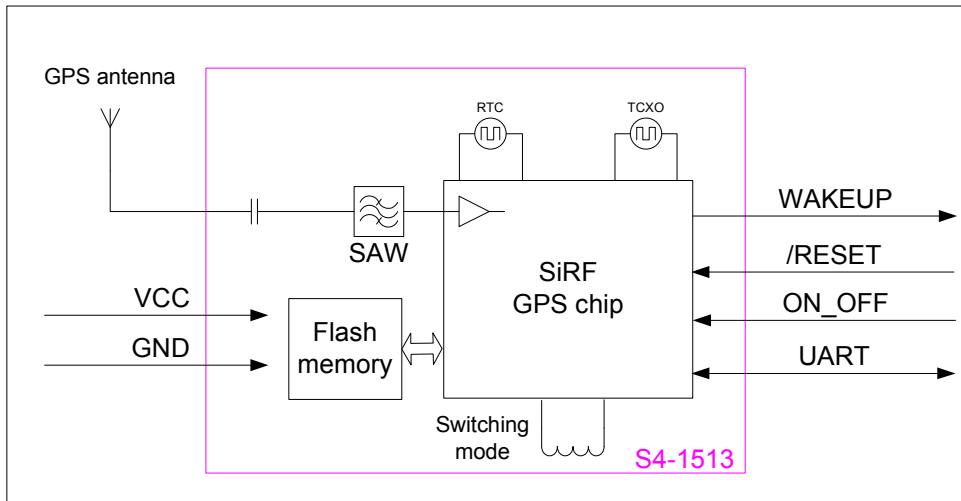

Fig 3-1 System block diagram.

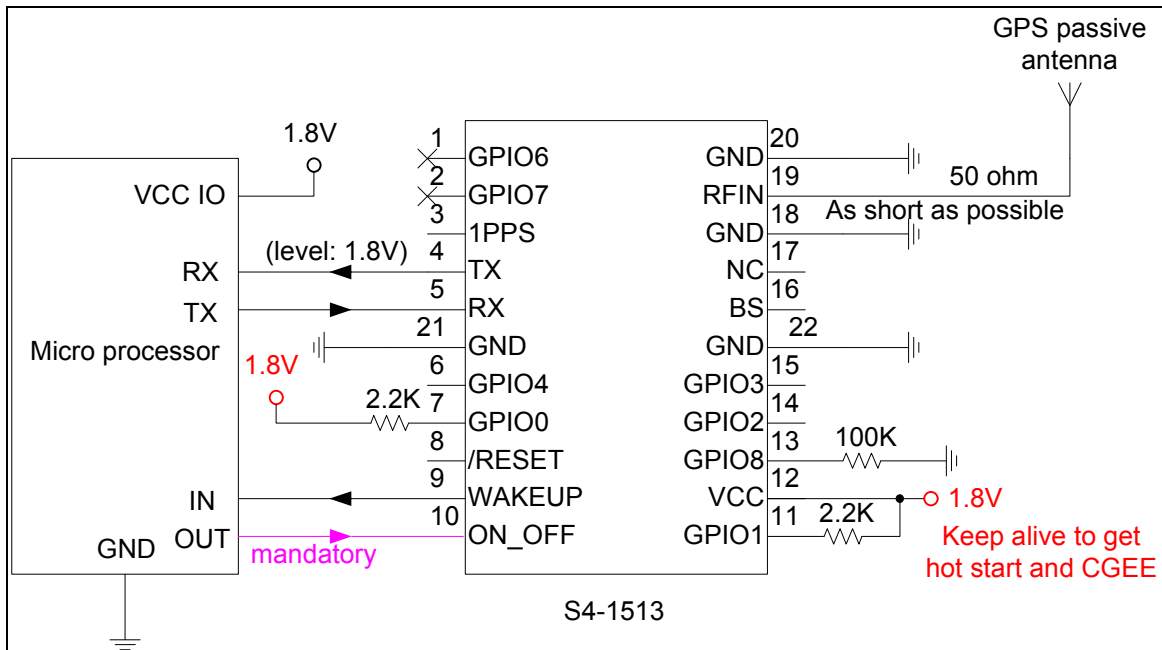

Fig 3-2 Typical application circuit that uses a passive antenna.

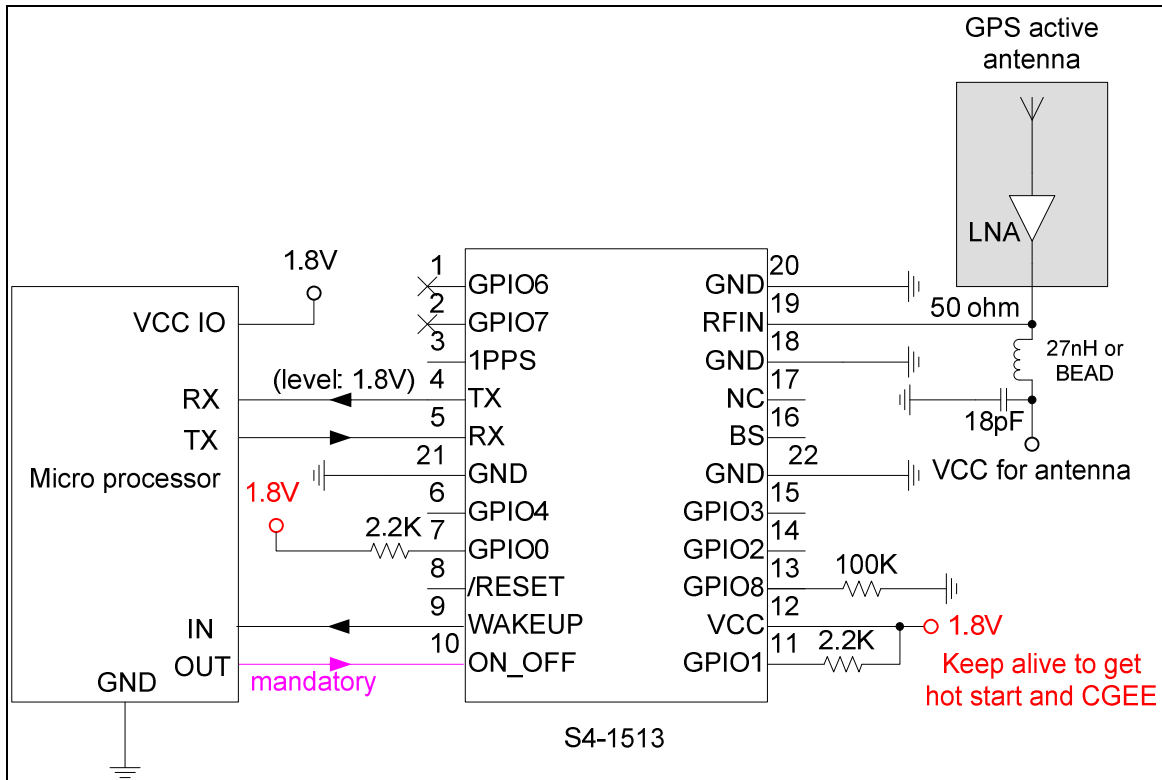

Fig 3-3 Typical application circuit that uses an active antenna

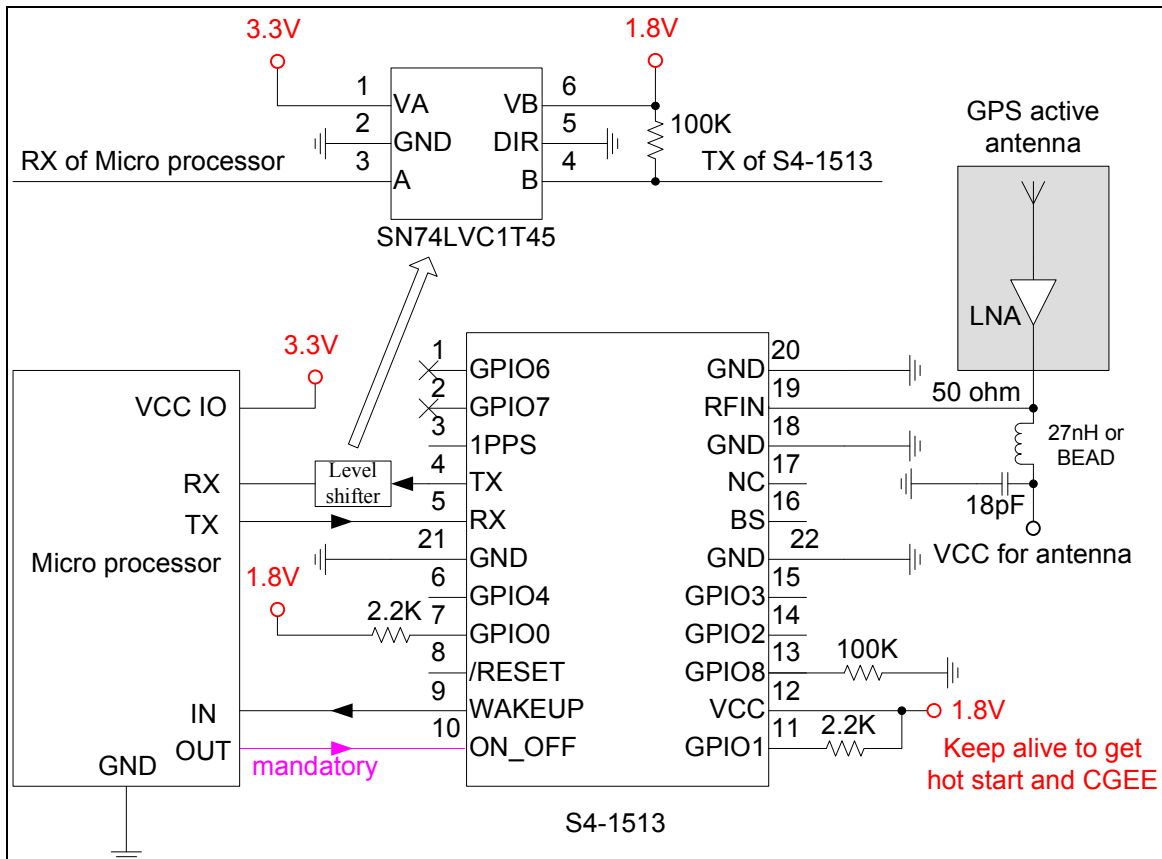

Fig 3-4 Use a level shifter for a micro processor of 3.3V IO voltage to communicate with S4-1513.

4 GPS receiver

Chip	SiRF Star IV, GSD4e-9411	
Frequency	L1 1575.42MHz, C/A code	
Channels	48	
Update rate	1Hz default, up to 5 Hz	
Sensitivity	Tracking	-159.5dBm, up to -163dBm (with external LNA)
	Navigation	-156.5dBm, up to -160dBm (with external LNA)
	Cold start	-144.5dBm, up to -148dBm (with external LNA)
Acquisition Time	Hot start (Open Sky)	< 1s (typical)
	Hot start (Indoor)	< 15s
	Cold Start (Open Sky)	32s (typical)
		< 15s (typical), CGEE-start
Position Accuracy	Autonomous	3m (2D RMS)
	SBAS	2.5m (depends on accuracy of correction data)
Max. Altitude	< 18,000 m	
Max. Velocity	< 515 m/s	
Protocol Support	NMEA 0183 ver 3.0	9600 bps ⁽¹⁾ , 8 data bits, no parity, 1 stop bits (default) 1Hz: GGA, GLL, GSA, GSV, RMC, VTG
	OSP Binary	115200 bps, 8 data bits, no parity, 1 stop bits

Note 1: Both baud rate and output message rate are configurable.

Table 4.1 Navigation Parameters

Track smooth mode	Disabled
Static navigation mode	Enabled

5 Software interface

5.1 NMEA output message

Table 5.1-1 NMEA output message

NMEA record	Description
GGA	Global positioning system fixed data
GLL	Geographic position - latitude/longitude
GSA	GNSS DOP and active satellites
GSV	GNSS satellites in view
RMC	Recommended minimum specific GNSS data
VTG	Course over ground and ground speed

● **GGA--- Global Positioning System Fixed Data**

Table 5.1-2 contains the values for the following example:

\$GPGGA,053740.000,2503.6319,N,12136.0099,E,1,08,1.1,63.8,M,15.2,M,,0000*64

Table 5.1-2 GGA Data Format

Name	Example	Units	Description
Message ID	\$GPGGA		GGA protocol header
UTC Time	053740.000		hhmmss.sss
Latitude	2503.6319		ddmm.mmmm
N/S indicator	N		N=north or S=south
Longitude	12136.0099		dddmm.mmmm
E/W Indicator	E		E=east or W=west
Position Fix Indicator	1		See Table 5.1-3
Satellites Used	08		Range 0 to 12
HDOP	1.1		Horizontal Dilution of Precision
MSL Altitude	63.8	mters	
Units	M	mters	
Geoid Separation	15.2	mters	
Units	M	mters	
Age of Diff. Corr.		second	Null fields when DGPS is not used
Diff. Ref. Station ID	0000		
Checksum	*64		
<CR> <LF>			End of message termination

Table 5.1-3 Position Fix Indicators

Value	Description
0	Fix not available or invalid
1	GPS SPS Mode, fix valid
2	Differential GPS, SPS Mode, fix valid
3-5	Not supported
6	Dead Reckoning Mode, fix valid

● **GLL--- Geographic Position – Latitude/Longitude**

Table 5.1-4 contains the values for the following example:

\$GPGLL,2503.6319,N,12136.0099,E,053740.000,A,A*52

Table 5.1-4 GLL Data Format

Name	Example	Units	Description
Message ID	\$GPGLL		GLL protocol header
Latitude	2503.6319		ddmm.mmmm
N/S indicator	N		N=north or S=south
Longitude	12136.0099		dddmm.mmmm
E/W indicator	E		E=east or W=west
UTC Time	053740.000		hhmmss.sss
Status	A		A=data valid or V=data not valid
Mode	A		A=autonomous, D=DGPS, E=DR
Checksum	*52		
<CR> <LF>			End of message termination

● GSA---GNSS DOP and Active Satellites

Table 5.1-5 contains the values for the following example:

\$GPGSA,A,3,24,07,17,11,28,08,20,04,,,,,2.0,1.1,1.7*35

Table 5.1-5 GSA Data Format

Name	Example	Units	Description
Message ID	\$GPGSA		GSA protocol header
Mode 1	A		See Table 5.1-6
Mode 2	3		See Table 5.1-7
ID of satellite used	24		Sv on Channel 1
ID of satellite used	07		Sv on Channel 2
....		
ID of satellite used			Sv on Channel 12
PDOP	2.0		Position Dilution of Precision
HDOP	1.1		Horizontal Dilution of Precision
VDOP	1.7		Vertical Dilution of Precision
Checksum	*35		
<CR> <LF>			End of message termination

Table 5.1-6 Mode 1

Value	Description
M	Manual- forced to operate in 2D or 3D mode
A	Automatic-allowed to automatically switch 2D/3D

Table 5.1-7 Mode 2

Value	Description
1	Fix not available
2	2D

3	3D
---	----

● GSV---GNSS Satellites in View

Table 5.1-8 contains the values for the following example:

\$GPGSV,3,1,12,28,81,285,42,24,67,302,46,31,54,354,,20,51,077,46*73

\$GPGSV,3,2,12,17,41,328,45,07,32,315,45,04,31,250,40,11,25,046,41*75

\$GPGSV,3,3,12,08,22,214,38,27,08,190,16,19,05,092,33,23,04,127,*7B

Table 5.1-8 GSV Data Format

Name	Example	Units	Description
Message ID	\$GPGSV		GSV protocol header
Total number of messages ¹	3		Range 1 to 3
Message number ¹	1		Range 1 to 3
Satellites in view	12		
Satellite ID	28		Channel 1 (Range 01 to 32)
Elevation	81	degrees	Channel 1 (Range 00 to 90)
Azimuth	285	degrees	Channel 1 (Range 000 to 359)
SNR (C/No)	42	dB-Hz	Channel 1 (Range 00 to 99, null when not tracking)
Satellite ID	20		Channel 4 (Range 01 to 32)
Elevation	51	degrees	Channel 4 (Range 00 to 90)
Azimuth	077	degrees	Channel 4 (Range 000 to 359)
SNR (C/No)	46	dB-Hz	Channel 4 (Range 00 to 99, null when not tracking)
Checksum	*73		
<CR> <LF>			End of message termination

1. Depending on the number of satellites tracked multiple messages of GSV data may be required.

● RMC---Recommended Minimum Specific GNSS Data

Table 5.1-9 contains the values for the following example:

\$GPRMC,053740.000,A,2503.6319,N,12136.0099,E,2.69,79.65,100106,,A*53

Table 5.1-9 RMC Data Format

Name	Example	Units	Description
Message ID	\$GPRMC		RMC protocol header
UTC Time	053740.000		hhmmss.sss
Status	A		A=data valid or V=data not valid
Latitude	2503.6319		ddmm.mmmm
N/S Indicator	N		N=north or S=south
Longitude	12136.0099		dddmm.mmmm
E/W Indicator	E		E=east or W=west

Speed over ground	2.69	knots	True
Course over ground	79.65	degrees	
Date	100106		ddmmyy
Magnetic variation		degrees	
Variation sense			E=east or W=west (Not shown)
Mode	A		A=autonomous, D=DGPS, E=DR
Checksum	*53		
<CR> <LF>			End of message termination

● VTG---Course Over Ground and Ground Speed

Table 5.1-10 contains the values for the following example:

\$GPVTG,79.65,T,,M,2.69,N,5.0,K,A*38

Table 5.1-10 VTG Data Format

Name	Example	Units	Description
Message ID	\$GPVTG		VTG protocol header
Course over ground	79.65	degrees	Measured heading
Reference	T		True
Course over ground		degrees	Measured heading
Reference	M		Magnetic
Speed over ground	2.69	knots	Measured speed
Units	N		Knots
Speed over ground	5.0	km/hr	Measured speed
Units	K		Kilometer per hour
Mode	A		A=autonomous, D=DGPS, E=DR
Checksum	*38		
<CR> <LF>			End of message termination

5.2 Proprietary NMEA input message

Table 5.2-1 Message Parameters

Start Sequence	Payload	Checksum	End Sequence
\$PSRF<MID> ¹	Data ²	*CKSUM ³	<CR><LF> ⁴

1. Message Identifier consisting of three numeric characters. Input messages begin at MID 100.
2. Message specific data. Refer to a specific message section for <data>...<data> definition.
3. CKSUM is a two-hex character checksum as defined in the NMEA specification, *NMEA-0183Standard For Interfacing Marine Electronic Devices*. Use of checksums is required on all input messages.
4. Each message is terminated using Carriage Return (CR) Line Feed (LF) which is \r\n which is hex 0D0A. Because \r\n are not printable ASCII characters, they are omitted from the example strings, but must be sent to terminate the

message and cause the receiver to process that input message.

Note: All fields in all proprietary NMEA messages are required, none are optional. All NMEA messages are comma delimited.

Table 5.2-2 Proprietary NMEA input messages

Message	MID ¹	Description
SetSerialPort	100	Set PORT A parameters and protocol
NavigationInitialization	101	Parameters required for start using X/Y/Z ²
SetDGPSPort	102	Set PORT B parameters for DGPS input
Query/Rate Control	103	Query standard NMEA message and/or set output rate
LLANavigationInitialization	104	Parameters required for start using Lat/Lon/Alt ³
Development Data On/Off	105	Development Data messages On/Off
Select Datum	106	Selection of datum to be used for coordinate transformations

1. Message Identification (MID).
2. Input coordinates must be WGS84.
3. Input coordinates must be WGS84

● 100---SetSerialPort

This command message is used to set the protocol (SiRF binary or NMEA) and/or the communication parameters (Baud, data bits, stop bits, and parity). Generally, this command is used to switch the module back to SiRF binary protocol mode where a more extensive command message set is available. When a valid message is received, the parameters are stored in battery-backed SRAM and the Evaluation Receiver restarts using the saved parameters.

Table 5.2-3 contains the input values for the following example:

Switch to SiRF binary protocol at 9600,8,N,1

\$PSRF100,0,9600,8,1,0*0C

Table 5.2-3 Set Serial Port Data Format

Name	Example	Units	Description
Message ID	\$PSRF100		PSRF100 protocol header
Protocol	0		0=SiRF binary, 1=NMEA
Baud	9600		4800,9600,19200,38400,57600,115200
DataBits	8		8,7 ¹
StopBits	1		0,1
Parity	0		0=None, 1=Odd, 2=Even
Checksum	*0C		
<CR><LF>			End of message termination

1. SiRF protocol is only valid for 8 data bits, 1 stop bit, and no parity.

● 101---NavigationInitialization

This command is used to initialize the Evaluation Receiver by providing current position (in X, Y, Z coordinates), clock offset, and time. This enables the Evaluation Receiver to search for the correct satellite signals at the correct signal parameters. Correct initialization parameters enable the Evaluation Receiver to acquire signals quickly.

Table 5.2-4 contains the input values for the following example:

Start using known position and time

```
$PSRF101,-2686700,-4304200,3851624,96000,497260,921,12,3*1C
```

Table 5.2-4 Navigation Initialization Data Format

Name	Example	Units	Description
Message ID	\$PSRF101		PSRF101 protocol header
ECEF X	-2686700	meters	X coordinate position
ECEF Y	-4304200	meters	Y coordinate position
ECEF Z	3851624	meters	Z coordinate position
ClkOffset	96000	Hz	Clock Offset of the Evaluation Receiver ¹
TimeOfWeek	497260	seconds	GPS Time Of Week
WeekNo	921		GPS Week Number
ChannelCount	12		Range 1 to 12
ResetCfg	3		See Table 5.2-5
Checksum	*1C		
<CR><LF>			End of message termination

1. Use 0 for last saved value if available. If this is unavailable, a default value of 96000 is used.

Table 5.2-5 Reset Configuration

Hex	Description
0x01	Hot Start – All data valid
0x02	Warm Start – Ephemeris cleared
0x03	Warm Start (with Init) – Ephemeris cleared, initialization data loaded
0x04	Cold Start – Clears all data in memory
0x08	Clear Memory – Clears all data in memory and resets the receiver back to factory defaults

● 102---SetDGPSPort

This command is used to control the serial port used to receive RTCM differential corrections. Differential receivers may output corrections using different communication parameters. If a DGPS receiver is used that has different communication parameters, use this command to allow the receiver to correctly decode the data. When a valid message is received, the parameters are stored in battery-backed SRAM and the receiver restarts using the saved parameters.

Table 5.2-6 contains the input values for the following example:

Set DGPS Port to be 9600,8,N,1.

```
$PSRF102,9600,8,1,0*12
```

Table 5.2-6 Set GPS Port Data Format

Name	Example	Units	Description
Message ID	\$PSRF102		PSRF102 protocol header
Baud	9600		4800,9600,19200,38400
DataBits	8		8,7
StopBits	1		0,1
Parity	0		0=None, 1=Odd, 2=Even
Checksum	*12		
<CR><LF>			End of message termination

Note: RTCM is not supported.

● 103---Query/Rate Control

This command is used to control the output of standard NMEA messages GGA, GLL, GSA, GSV, RMC, and VTG.

Using this command message, standard NMEA messages may be polled once, or setup for periodic output. Checksums may also be enabled or disabled depending on the needs of the receiving program. NMEA message settings are saved in battery-backed memory for each entry when the message is accepted.

Table 5.2-7 contains the input values for the following example:

1. Query the GGA message with checksum enabled

\$PSRF103,00,01,00,01*25

2. Enable VTG message for a 1 Hz constant output with checksum enabled

\$PSRF103,05,00,01,01*20

3. Disable VTG message

\$PSRF103,05,00,00,01*21

Table 5.2-7 Query/Rate Control Data Format (See example 1)

Name	Example	Units	Description
Message ID	\$PSRF103		PSRF103 protocol header
Msg	00		See Table 5.2-8
Mode	01		0=SetRate, 1=Query
Rate	00	seconds	Output – off=0, max=255
CksumEnable	01		0=Disable Checksum, 1=Enable Checksum
Checksum	*25		
<CR><LF>			End of message termination

Table 5.2-8 Messages

Value	Description
0	GGA
1	GLL

2	GSA
3	GSV
4	RMC
5	VTG
6	MSS (If internal beacon is supported)
7	Not defined
8	ZDA (if 1PPS output is supported)
9	Not defined

● 104---LLANavigationInitialization

This command is used to initialize the Evaluation Receiver by providing current position (in latitude, longitude, and altitude coordinates), clock offset, and time. This enables the receiver to search for the correct satellite signals at the correct signal parameters. Correct initialization parameters enable the receiver to acquire signals quickly.

Table 5.2-9 contains the input values for the following example:

Start using known position and time.

```
$PSRF104,37.3875111,-121.97232,0,96000,237759,1946,12,1*07
```

Table 5.2-9 LLA Navigation Initialization Data Format

Name	Example	Units	Description
Message ID	\$PSRF104		PSRF104 protocol header
Lat	37.3875111	degrees	Latitude position (Range 90 to -90)
Lon	-121.97232	degrees	Longitude position (Range 180 to -180)
Alt	0	meters	Altitude position
ClkOffset	96000	Hz	Clock Offset of the Evaluation Receiver ¹
TimeOfWeek	237759	seconds	GPS Time Of Week
WeekNo	1946		Extended GPS Week Number (1024 added)
ChannelCount	12		Range 1 to 12
ResetCfg	1		See Table 5.2-10
Checksum	*07		
<CR><LF>			End of message termination

1. Use 0 for last saved value if available. If this is unavailable, a default value of 96000 is used.

Table 5.2-10 Messages

Hex	Description
0x01	Hot Start – All data valid
0x02	Warm Start – Ephemeris cleared
0x03	Warm Start (with Init) – Ephemeris cleared, initialization data loaded

0x04	Cold Start – Clears all data in memory
0x08	Clear Memory – Clears all data in memory and resets receiver back to factory defaults

● 105---Development Data On/Off

Use this command to enable development data information if you are having trouble getting commands accepted. Invalid commands generate debug information that enables you to determine the source of the command rejection. Common reasons for input command rejection are invalid checksum or parameter out of specified range.

Table 5.2-11 contains the input values for the following example:

1. Debug On
\$PSRF105,1*3E
2. Debug Off
\$PSRF105,0*3F

Table 5.2-11 Development Data On/Off Data Format

Name	Example	Units	Description
Message ID	\$PSRF105		PSRF105 protocol header
Debug	1		0=Off, 1=On
Checksum	*3E		
<CR><LF>			End of message termination

● 106---Select Datum

\$PSGPS receivers perform initial position and velocity calculations using an earth-centered earth-fixed (ECEF) coordinate system. Results may be converted to an earth model (geoid) defined by the selected datum. The default datum is WGS 84 (World Geodetic System 1984) which provides a worldwide common grid system that may be translated into local coordinate systems or map datums. (Local map datums are a best fit to the local shape of the earth and not valid worldwide.)

Table 5.2-12 contains the input values for the following example:

- Datum select TOKYO_MEAN
\$PSRF106,178*32

Table 5.2-12 Development Data On/Off Data Format

Name	Example	Units	Description
Message ID	\$PSRF106		PSRF106 protocol header
Datum	178		21=WGS84 178=TOKYO_MEAN 179=TOKYO_JAPAN 180=TOKYO_KOREA 181=TOKYO_OKINAWA
Checksum	*32		

<CR><LF>			End of message termination
----------	--	--	----------------------------

● 117---System Turn Off

This message requests that the GPS receiver perform an orderly shutdown and switch to hibernate mode.

Table 5.2-13 contains the values for the following example:

\$PSRF117,16*0B

Table 5.2-13 System Turn Off

Name	Example	Units	Description
Message ID	\$PSRF117		PSRF117 protocol header
Sub ID	16		16: System turn off
Checksum	*0B		
<CR><LF>			End of message termination

5.3 Supply voltage control and sequencing

5.3.1 Initial power up

When power is first applied, the module goes into a low-power mode while RTC starts. The host is not required to control /RESET pin (pin 8 of GPS module) since the module's internal reset circuitry handles detection of application of power. After that, the module is in "ready-to-start" state and awaits an ON_OFF input pulse to start.

Since RTC startup time is variable, detection of when the module is ready to accept an ON_OFF pulse requires the host to either wait for a fixed interval or to monitor a pulse on WAKEUP output (pin 9 of GPS module) to assert a pulse on the ON_OFF input. An example flow chart is shown below.

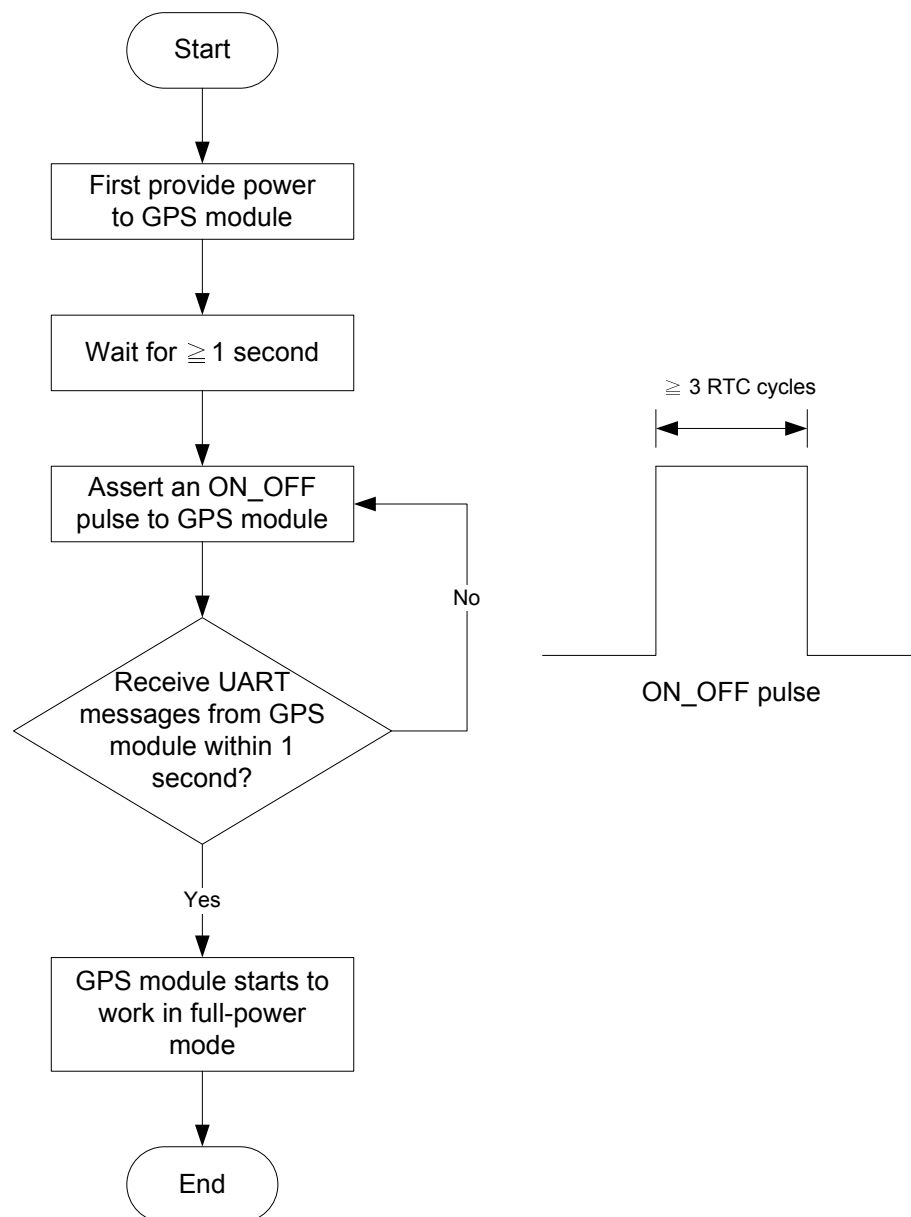

5.3.2 Procedure for removing power of GPS module

Abrupt, uncontrolled removal of power while GPS module is operating carries the risk of data corruption. The consequences of corruption range from longer TimeToFirstFix to complete system failure. The appropriate procedure to remove power is shown as below.

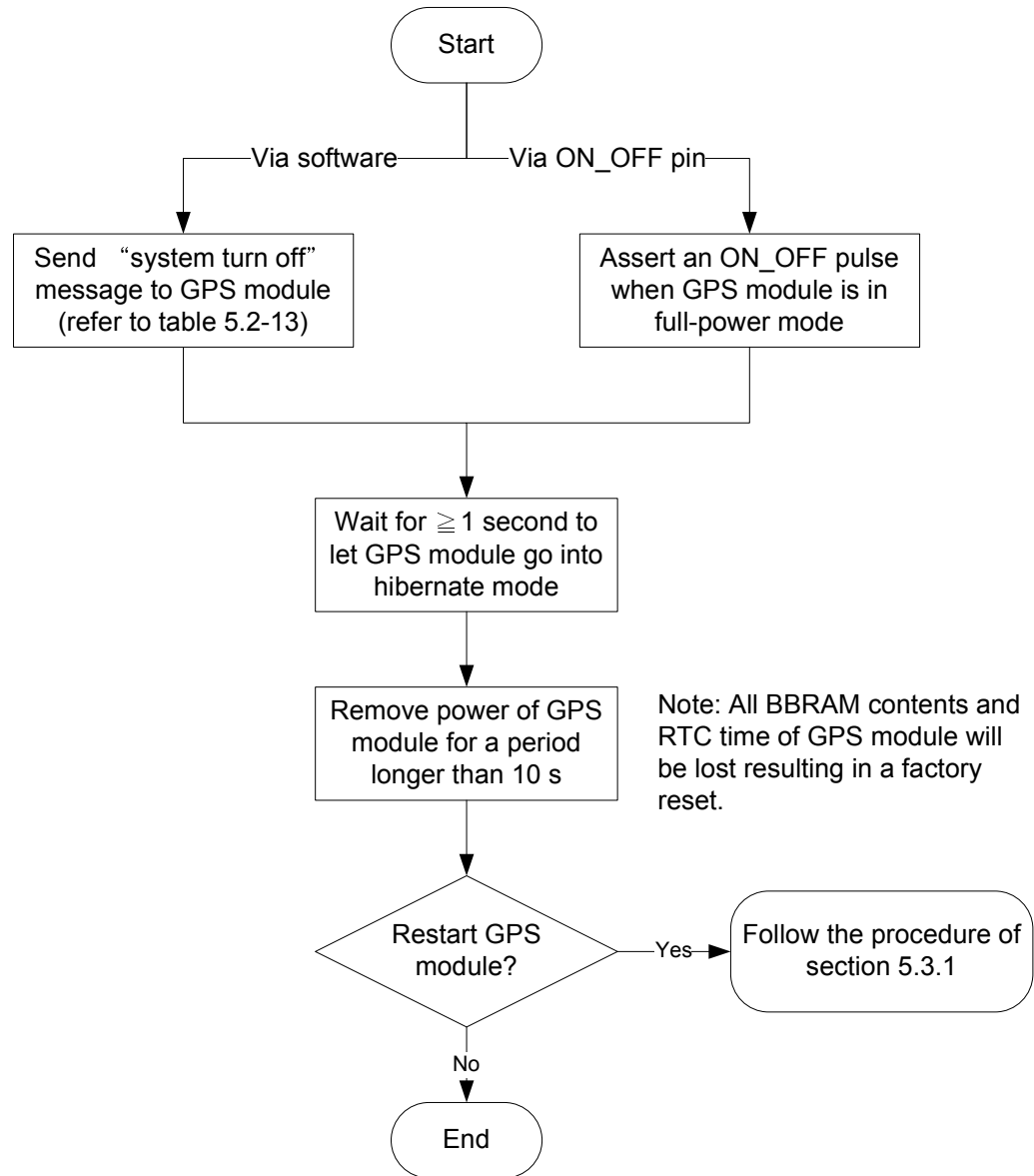

6 Pin assignment and descriptions

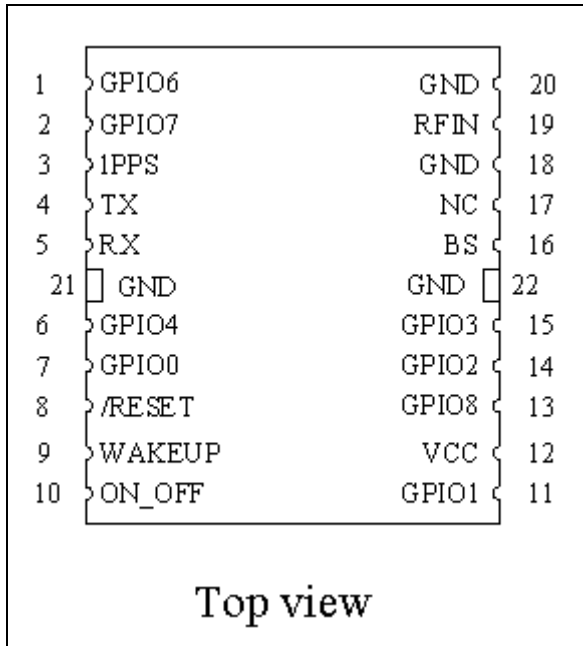

Table 6-1 Pin descriptions

Pin #	Name	Type	Description	Note
1	GPIO6	I/O	General purpose I/O Do not connect for default UART interface.	1
2	GPIO7	I/O	General purpose I/O Do not connect for default UART interface.	1
3	1PPS	O	Pulse per second (200 ms pulse)	
4	TX	O	Serial output (Default NMEA)	
5	RX	I	Serial input (Default NMEA)	1
6	GPIO4	I/O	General purpose I/O	1
7	GPIO0	I/O	General purpose I/O Please connect a 2.2KΩ pull-up resistor to VCC	1
8	/RESET	I	External reset input with internal pull-up, active low. GPS module has internal power on reset that is the preferred system reset method. External reset will clear all BBRAM and SRAM.	1
9	WAKEUP	O	Wake up output. A high on this output indicates that GPS module is in operational mode. A low on this output indicates that GPS module is in low power state (standby, hibernate and ready-to-start). User can use this pin to control external power supply, LNA or external GPS antenna.	

10	ON_OFF	I	Power control pin. Internal 10K Ω pull-down resistor.	1,2
11	GPIO1	I/O	General purpose I/O Please connect a 2.2K Ω pull-up resistor to VCC	1
12	VCC	P	DC supply voltage	
13	GPIO8	I/O	General purpose I/O Please connect a 100K Ω pull-down resistor to GND	1
14	GPIO2	I/O	General purpose I/O	1
15	GPIO3	I/O	General purpose I/O	1
16	BS	I	Boot mode select (Do not connect in normal operation)	
17	NC		Not connected	
18	GND	P	Ground	
19	RFIN	I	GPS RF signal input	
20	GND	P	Ground	
21	GND	P	Ground	
22	GND	P	Ground	

<Note>

1. Input voltage is 3.6V tolerant.
2. Input pulse to start the module, and switch the module between different power modes.
 - ON_OFF pulse requires a rising edge and high level that persists for three cycles of the RTC clock in order to be detected. Resetting the ON_OFF detector requires that ON_OFF goes to logic low for at least three cycles of the RTC clock.
 - If the module is first powered, i.e. in “ready-to-start” state, an ON_OFF pulse will start the module.
 - If the module is in hibernate state, an ON_OFF pulse will move it to full-power mode.
 - If the module is in MicroPower mode, an ON_OFF pulse will move it to full-power mode.
 - If the module is in AdvancedPower mode, an ON_OFF pulse will initiate one AdvancedPower cycle.
 - If the module is in TricklePower mode, an ON_OFF pulse will initiate one TricklePower cycle.
 - If the module is in Push-To-Fix mode, an ON_OFF pulse will initiate one Push-To-Fix cycle.
 - If the module is already in full-power mode, an ON_OFF pulse will initiate orderly shutdown.

7 DC & Temperature characteristics

7.1 Absolute maximum ratings

Parameter	Symbol	Ratings	Units
DC Supply Voltage	VCC	1.95	V
I/O Pin Voltage	VIO	3.6	V
Operating Temperature Range	Topr	-40 ~ 85	°C
Storage Temperature Range	Tstg	-40 ~ 85	°C

7.2 DC Electrical characteristics

Parameter	Symbol	Conditions	Min.	Typ.	Max.	Units
DC Supply Voltage	VCC		1.71	1.8	1.89	V
Supply Current (Switching mode)	Iss	VIN = 1.8V Peak Acquisition		46	130	mA
		Tracking		27.5		mA
		Standby ⁽¹⁾		93		uA
		Hibernate		20		uA
		Ready-to-start ⁽²⁾ MPM ⁽³⁾		9 250 ⁽⁴⁾		uA uA
High Level Input Voltage	V _{IH}		0.7*VCC		3.6	V
Low Level Input Voltage	V _{IL}		-0.4		0.45	V
High Level Output Voltage	V _{OH}		0.75*VCC		VCC	V
Low Level Output Voltage	V _{OL}				0.4	V
High Level Output Current	I _{OH}			2		mA
Low Level Output Current	I _{OL}			2		mA
Input Capacitance	C _{IN}			5		pF
Load Capacitance	C _{LOAD}				8	pF

<Note>

1. Transitional state when GPS module is in TricklePower mode.
2. When power is first applied, the module goes into a “ready-to-start” state. Please refer to the section 5.3.
3. MicroPowerMode.
4. The value of each module is different.

7.3 Temperature characteristics

Parameter	Symbol	Min.	Typ.	Max.	Units
Operating Temperature	Topr	-30	-	85	°C
Storage Temperature	Tstg	-40	25	85	°C

8 Mechanical specification

8.1 Outline dimensions

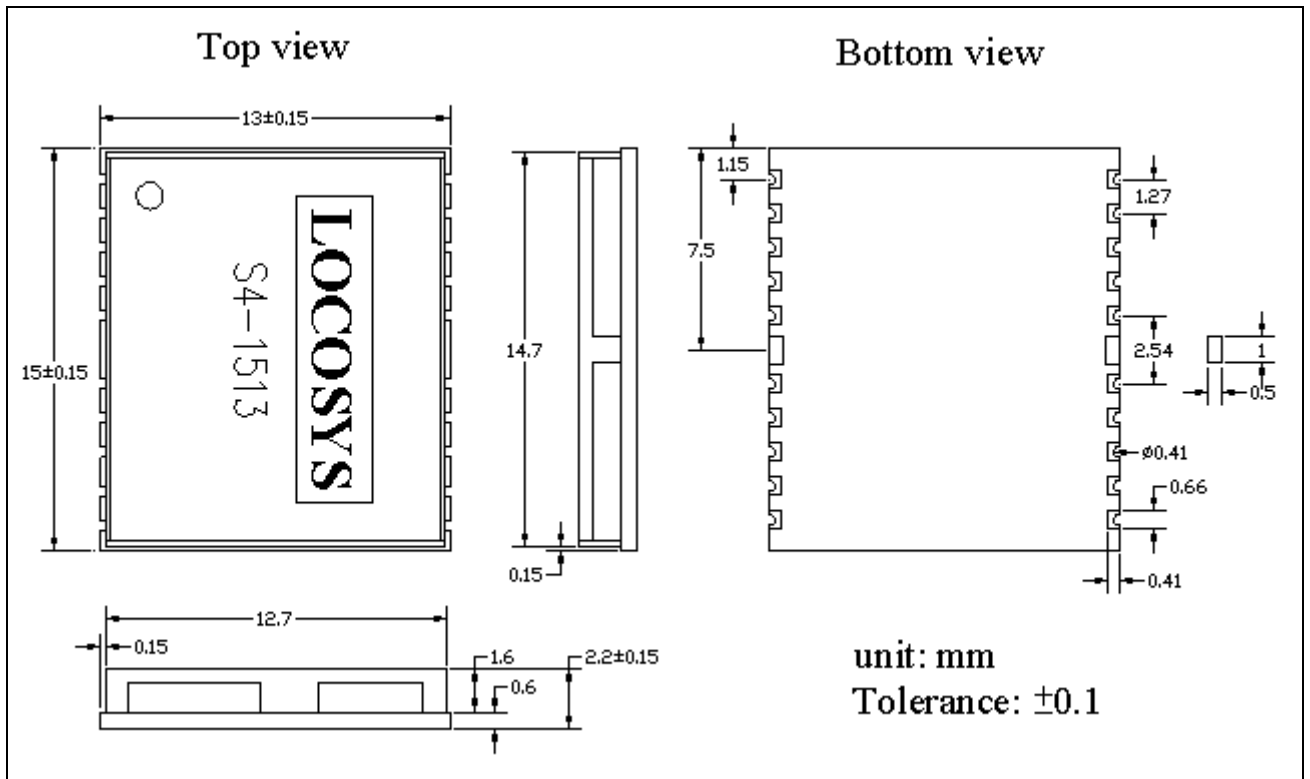

8.2 Recommended land pattern dimensions

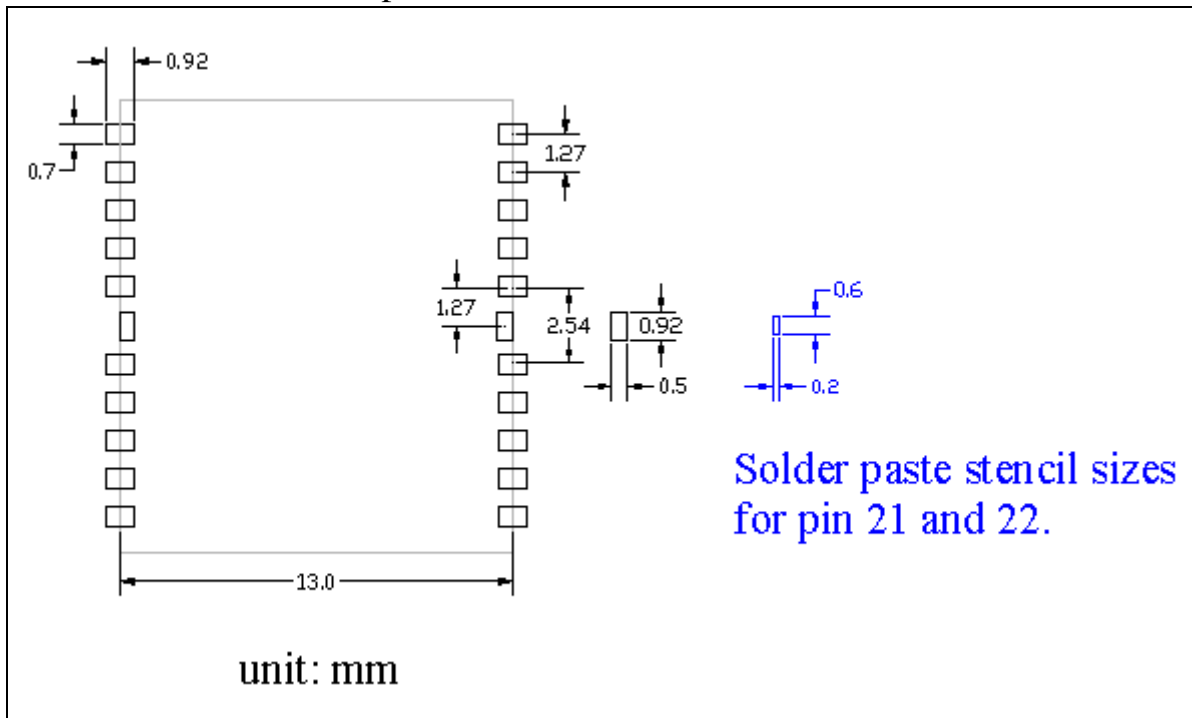

9 Reel Packing information

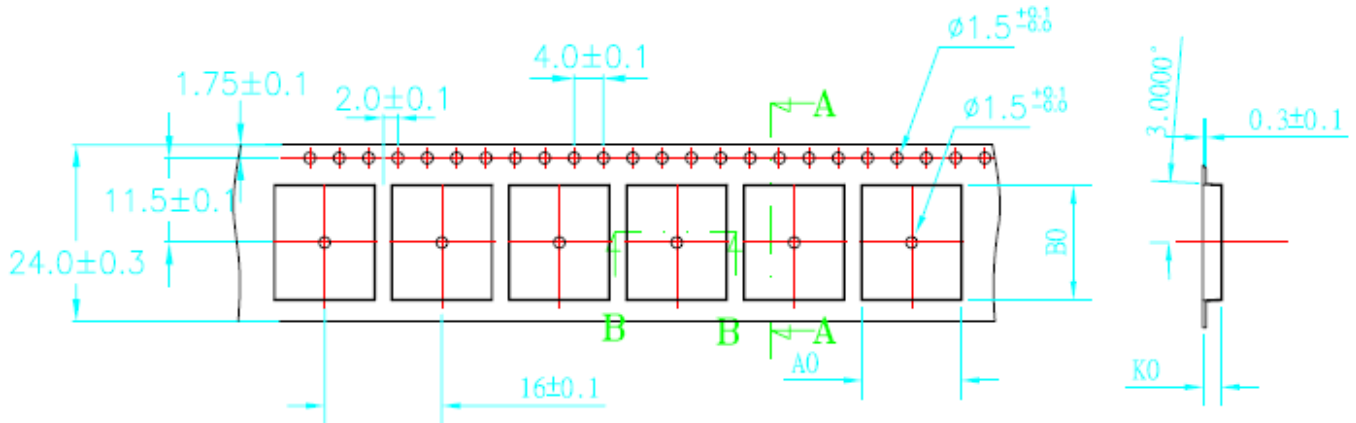

SECTION A-A

ITEM	DIM	ALTERNATE
A0	13.5 ^{+0.10} _{-0.10}	
B0	15.5 ^{+0.10} _{-0.10}	
K0	2.5 ^{+0.10} _{-0.10}	

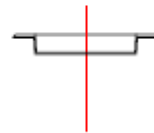

SECTION B-B

1. 10 sprocket hole pitch cumulative tolerance $\pm 0.20\text{mm}$.
2. Carrier camber not to exceed 1mm in 100mm.
3. A0 and B0 measured on a plane 0.3mm above the bottom of the pocket.
4. K0 measured from a plane on the inside bottom of the pocket to the top surface of the carrier.
5. All dimensions meet EIA-481-2 requirements.
6. Material: Black Anti-Static Polystyrene.
7. Component load per 13" reel :1000 pcs.

Document change list

Revision 1.0

- First release on Dec. 24, 2010.

Revision 1.0 to Revision 1.1 (March 15, 2011)

- Upgraded GPS firmware to version 4.1.0.
- Added “Up to 5 Hz update rate” on page 1.
- Added 115200 in the Table 5.2-3 on page 9.
- Changed tracking current from 31mA to 27.5mA on page 19.
- Changed MPM current from 550uA to 250uA on page 19.