

Product name	Description	Version
RTK-1722-T	Datasheet of RTK-1722-T L1/L5 GNSS module	0.1

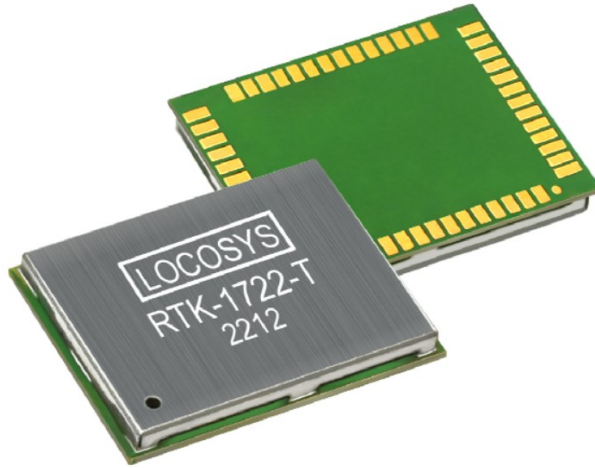

1 Introduction

The RTK-1722-T is a high-performance L1 and L5 dual-band, multi-frequency, high data rate GNSS RTK module that designed for applications requiring centimeter level positioning accuracy. The module supports concurrent reception of GPS, GLONASS, BeiDou, GALILEO to improve the availability and reliability of RTK solution even in the harsh environment.

2 Features

- Dual-band, multi-frequency and with maximum fixed update rate up to 10Hz
- GNSS based timing solution for O-RAN (Open Radio Access Network)
- Low power consumption
- Fast TTFF at low signal level
- RTCM ready (RTCM v2.3 and v3.3)
- SMD type; RoHS compliant
- IATF 16949 quality control

3 System Block Diagram

RTK-1722-T Block Diagram

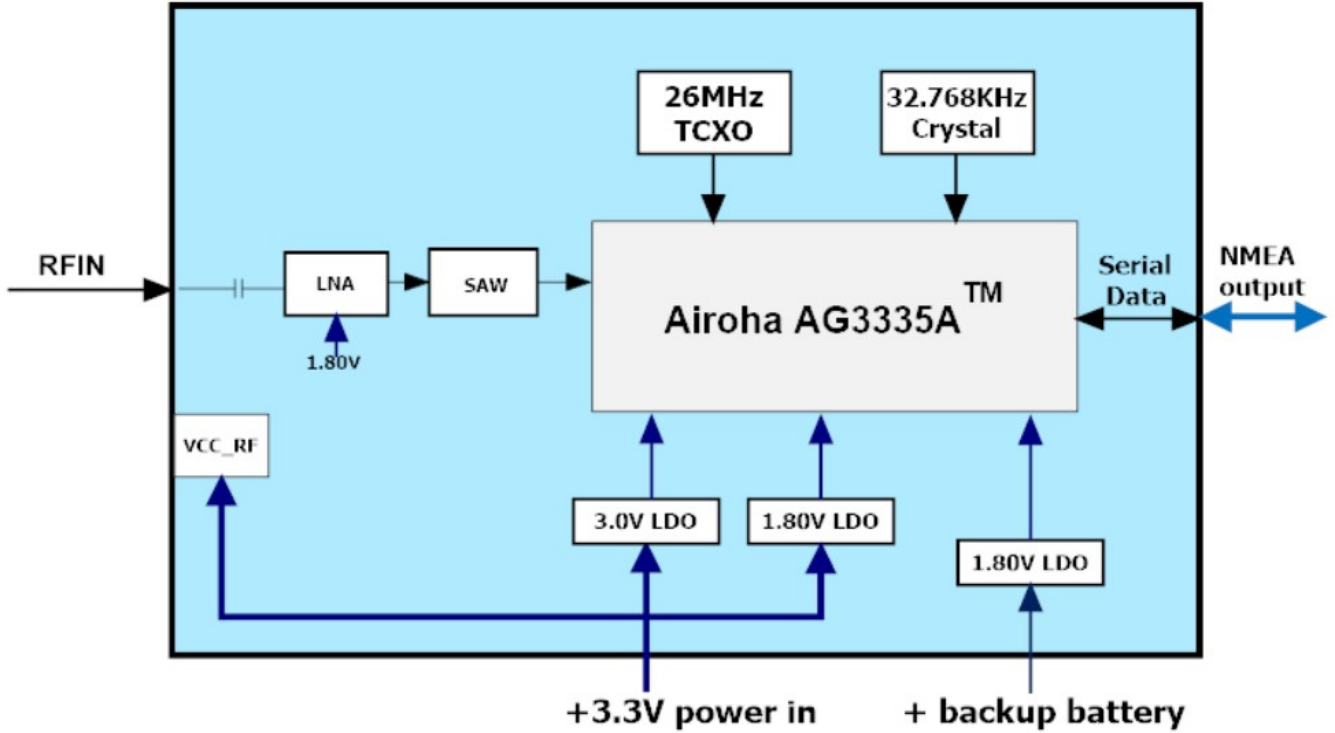

Fig 3-1 System block diagram.

4 GNSS receiver

4.1 GNSS receiver

Chip	Airoha AG3335A	
Frequency	GPS: L1 C/A, L5C GLONASS: L1OF GALILEO: E1, E5a BEIDOU: B1I, B2a	
Channels	Support 135 channels	
Update rate	1Hz default	
Sensitivity	Tracking	Up to -166dBm
	Cold start	Up to -147dBm
Acquisition Time	Cold Start (Open Sky)	27s (typical)
	Hot Start (Open Sky)	2s (typical)
Position Accuracy	Autonomous ⁽¹⁾⁽²⁾	(TBD) m CEP
Time Pulse Accuracy	<5ns, up to 2ns ⁽²⁾	
Max. Altitude	< 18,000 m	
Max. Velocity	< 515 m/s	
Protocol Support	NMEA 0183 ver 4.1	115200 bps, 8 data bits, no parity, 1 stop bits (default) 1Hz: GSV, GGA, GLL, GSA, RMC, VTG

Note 1: With full DCB (Differential Code Bias) calibration.

Note 2: Depends on the satellite visibility, geometric distribution of satellites in the sky, and received signal quality and characteristics.

5 Pin assignment (Top View)

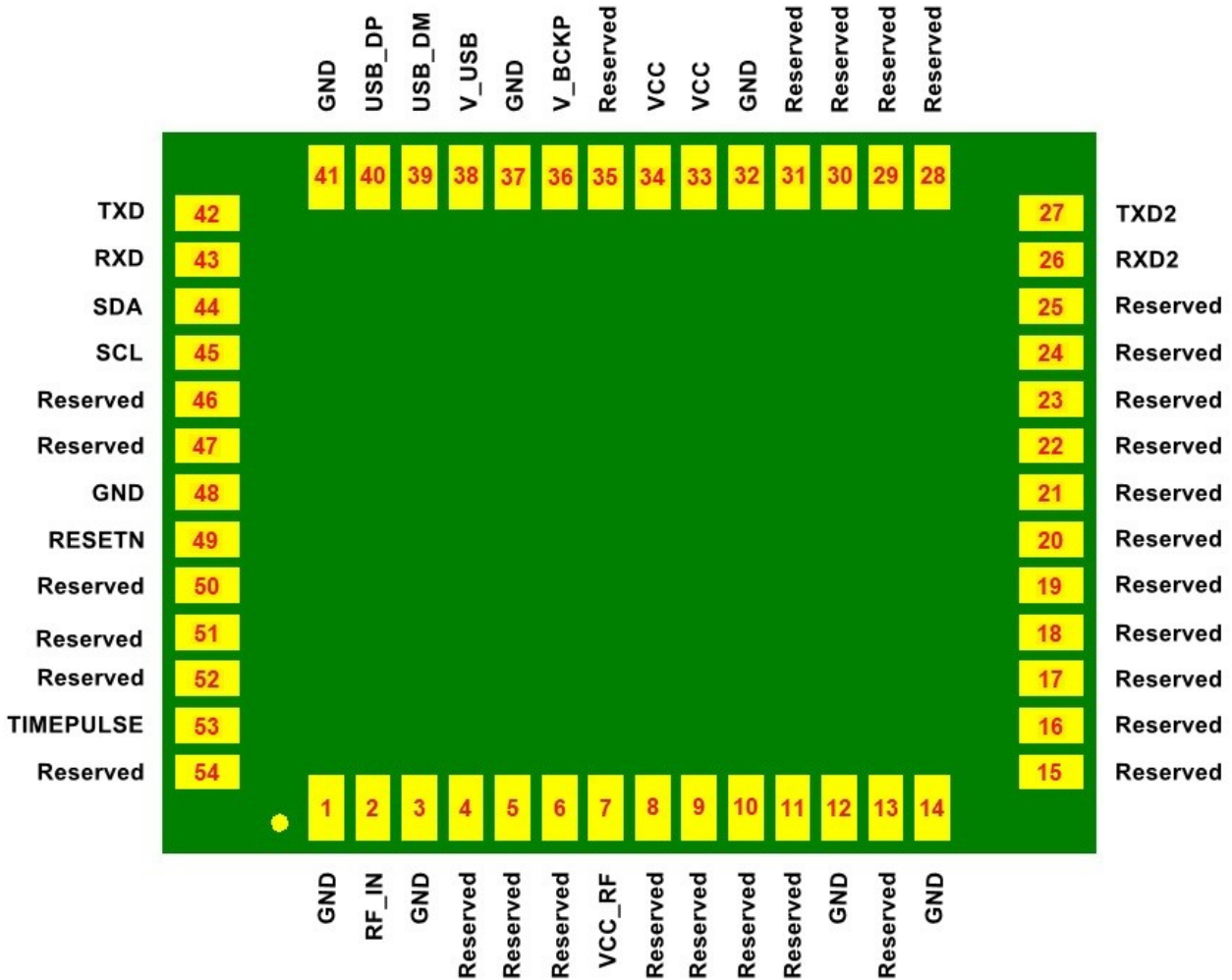

Table 5-1 Pin descriptions

Pin no.	Name	Type	Description	Note
1	GND		Ground	
2	RF_IN	I	GNSS RF signal input	
3	GND		Ground	
4	Reserved		Reserved, keep floating.	
5	Reserved		Reserved, keep floating.	
6	Reserved		Reserved, keep floating.	
7	VCC_RF	O	Output voltage (same as VCC) for active antenna	1
8	Reserved		Reserved, keep floating.	
9	Reserved		Reserved, keep floating.	
10	Reserved		Reserved, keep floating.	

11	Reserved		Reserved, keep floating.	
12	GND		Ground	
13	Reserved		Reserved, keep floating.	
14	GND		Ground	
15	Reserved		Reserved, keep floating	
16	Reserved		Reserved, keep floating.	
17	Reserved		Reserved, keep floating.	
18	Reserved		Reserved, keep floating.	
19	Reserved		Reserved, keep floating.	
20	Reserved		Reserved, keep floating.	
21	Reserved		Reserved, keep floating.	
22	Reserved		Reserved, keep floating.	
23	Reserved		Reserved, keep floating.	
24	Reserved		Reserved, keep floating.	
25	Reserved		Reserved, keep floating.	
26	RXD2	I	UART, asynchronous input, keep floating if not used.	
27	TXD2	O	UART, asynchronous output, keep floating if not used.	
28	Reserved		Reserved, keep floating.	
29	Reserved		Reserved, keep floating.	
30	Reserved		Reserved, keep floating.	
31	Reserved		Reserved, keep floating.	
32	GND		Ground	
33	VCC	I	DC supply voltage	
34	VCC	I	DC supply voltage	
35	Reserved		Reserved, keep floating.	
36	V_BCKP	I	Backup supply voltage (Optional)	
37	GND		Ground	
38	V_USB	I	keep floating; no effect on USB function.	
39	USB_DM	I/O	USB 2.0 signal DM	
40	USB_DP	I/O	USB 2.0 signal DP	
41	GND		Ground	
42	TXD	O	UART, asynchronous output (default NMEA output)	
43	RXD	I	UART, asynchronous input	
44	SDA	I/O	Slave I2C data, internal pull up to 3.0V with 10K resistor.	
45	SCL	I/O	Slave I2C clock, internal pull up to 3.0V with 10K resistor.	
46	Reserved		Reserved, keep floating.	
47	Reserved		Reserved, keep floating.	
48	GND		Ground	
49	RESETN	I	Reset, 1.8V level, active low, keep floating if not used.	

50	Reserved		Reserved, keep floating.	
51	Reserved		Reserved, keep floating.	
52	Reserved		Reserved, keep floating.	
53	TIMEPULSE	O	Time pulse, 1 pps output.	
54	Reserved		Reserved, keep floating.	

Note 1: Please refer the antenna's specification to provide proper voltage.

6 DC & Temperature characteristics

6.1 Absolute maximum ratings

Parameter	Symbol	Ratings	Units
Input Voltage	VCC	3.6	V
Input Backup Battery Voltage	V_BCKP	3.6	V
Operating Temperature Range	Topr	-40 ~ 85	°C
Storage Temperature Range	Tstg	-40 ~ 85	°C

6.2 DC Electrical characteristics

Parameter	Symbol	Conditions	Min.	Typ.	Max.	Units
Input Voltage	VCC		3.3	3.3	3.6	V
Input Backup Battery Voltage	V_BCKP		3.0		3.6	V
VCC_RF Output Voltage	VCC_RF			VCC		V
Supply Current (VCC = 3.3V, w/o active antenna)	Iss	Acquisition		TBD		mA
		Tracking		TBD	TBD	mA
Backup Battery Current	Ibat	VCC = 0V		TBD		uA
VCC_RF Output Current	I _{out}	VIN = 3.3V			25	mA
High Level Input Voltage	V _{IH}		2.3		3.6	V
Low Level Input Voltage	V _{IL}		-0.3		0.8	V
High Level Output Voltage	V _{OH}		2.3			V
Low Level Output Voltage	V _{OL}				0.4	V

6.3 Temperature characteristics

Parameter	Symbol	Min.	Typ.	Max.	Units
Operating Temperature	Topr	-40	-	85	°C
Storage Temperature	Tstg	-40	25	85	°C

7 Mechanical specification

7.1 Outline dimensions

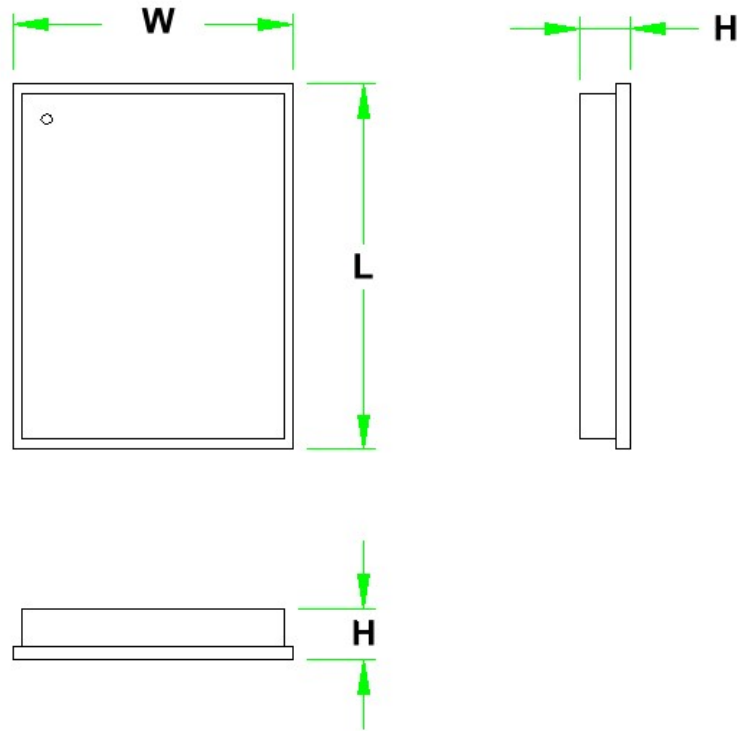

Symbol	Min. (mm)	Typ. (mm)	Max. (mm)
W		17.20	
L		22.30	
H		2.45	

7.2 Mechanical dimensions (Bottom View)

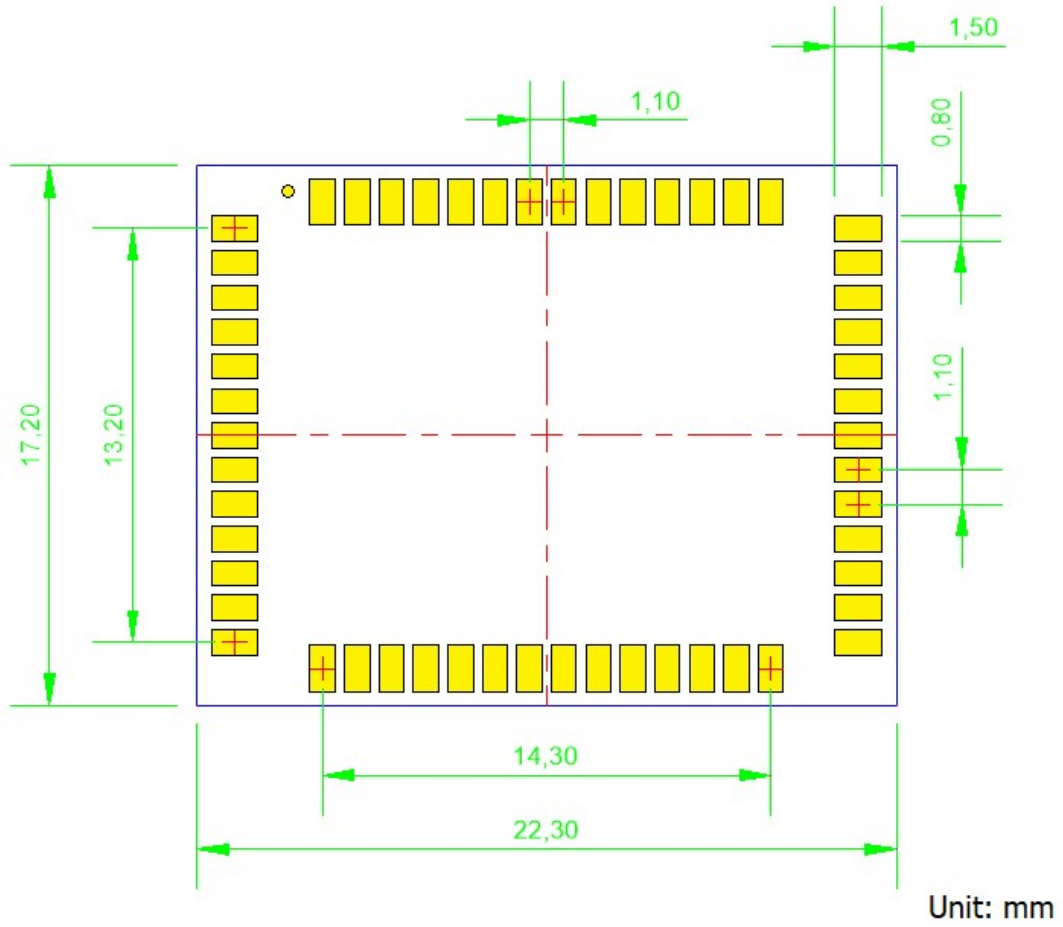

8 Software interface

8.1 NMEA output message

Table 8.1-1 NMEA output message

NMEA record	Description
GGA	Global positioning system fixed data
GLL	Geographic position - latitude/longitude
GSA	GNSS DOP and active satellites
GSV	GNSS satellites in view
RMC	Recommended minimum specific GNSS data
VTG	Course over ground and ground speed

- **GGA--- Global Positioning System Fixed Data**

Table 8.1-2 contains the values for the following example:

\$GNGGA,013654.000,2503.71447,N,12138.74593,E,1,16,0.7,130.00,M,15.3,M,,*72

Table 8.1- 2 GGA Data Format

Name	Example	Units	Description
Message ID	\$GNGGA		GGA protocol header
UTC Time	013654.000		hhmmss.sss
Latitude	2503.71447		ddmm.mmmmm
N/S indicator	N		Latitude Direction: North or South
Longitude	12138.74593		dddmm.mmmmm
E/W Indicator	E		Longitude Direction: East or West
Position Fix Indicator	1		See Table 8.1-3
Satellites Used	16		Satellites in use
HDOP	0.7		Horizontal Dilution of Precision,max:99.0
MSL Altitude	130.00	meters	Height above mean sea level
Units	M	meters	Reference Unit for Altitude (“M” = meters)
Geoidal Separation	15.3	meters	Geoidal Separation measure in “M” = meters
Units	M	meters	Reference Unit for Geoidal Separation (“M” = meters)
DGPS Age			Not supported
DGPS Reference			Not supported
Checksum	*72		
<CR> <LF>			End of message termination

Table 8.1-3 Position Fix Indicators

Value	Description
0	Fix not available or invalid
1	GNSS fix valid
2	Differential GNSS fix valid
4	RTK fixed
6	Estimated (Dead Reckoning) Mode

- **GLL--- Geographic Position – Latitude/Longitude**

Table 8.1-4 contains the values for the following example:

\$GNGLL,2503.71447,N,12138.74593,E,013654.000,A,A*42

Table 8.1-4 GLL Data Format

Name	Example	Units	Description
Message ID	\$GNGLL		GLL protocol header
Latitude	2503.71447		ddmm.mmmmm
N/S indicator	N		Latitude Direction: North or South
Longitude	12138.74593		dddmm.mmmmm
E/W indicator	E		Longitude Direction: East or West
UTC Time	013654.000		hhmmss.sss
Status	A		Validity of Data; A=data valid or V=data invalid
Mode	A		A = Autonomous mode, D = Differential mode, E = Estimated (Dead Reckoning) Mode, N=Data invalid,
Checksum	*42		
<CR> <LF>			End of message termination

- **GSA---GNSS DOP and Active Satellites**

Table 8.1-5 contains the values for the following example:

\$GNGSA,A,3,11,195,194,199,08,07,01,27,16,09,23,,1.19,0.64,1.00,1*3F

\$GNGSA,A,3,87,81,76,,,,,,,,,1.19,0.64,1.00,2*0F

\$GNGSA,A,3,,,,,,,,,,,,,1.19,0.64,1.00,3*09

\$GNGSA,A,3,34,24,12,07,11,10,08,38,25,09,13,16,1.19,0.64,1.00,4*02

Table 8.1-5 GSA Data Format

Name	Example	Units	Description
Message ID	\$GNGSA		GSA protocol header
Mode 1	A		See Table 8.1-6
Mode 2	3		See Table 8.1-7
ID of satellite used	11		SV on Channel 1

ID of satellite used	195		SV on Channel 2
....		
ID of satellite used			SV on Channel 12
PDOP	1.19		Position Dilution of Precision
HDOP	0.64		Horizontal Dilution of Precision
VDOP	1.00		Vertical Dilution of Precision
GNSS system ID	4		See Table 8.1-8
Checksum	*3F		

Table 8.1-6 Mode 1

Value	Description
M	Manual: forced to operate in 2D or 3D mode
A	Automatic: allowed to automatically switch 2D/3D

Table 8.1-7 Mode 2

Value	Description
1	No position fixed
2	2D fixed
3	3D fixed

Table 8.1-8 GNSS system ID

Value	Description
1	GPS
2	GLONASS
3	GALILEO
4	BEIDOU
6	IRNSS

● GSV---GNSS Satellites in View

Table 8.1-9 contains the values for the following example:

```
$GPGSV,3,1,09,8,71,268,47,27,63,18,49,11,44,191,46,4,41,237,46,1*54
$GPGSV,3,2,09,16,38,42,42,9,32,279,39,26,22,70,38,31,15,131,36,1*56
$GPGSV,3,3,09,7,15,320,40,1*6B
$GPGSV,1,1,04,8,71,268,50,27,63,18,49,9,32,279,43,26,22,70,42,8*6C
$GLGSV,2,1,05,82,63,47,47,83,56,182,36,80,47,9,42,79,33,85,45,1*71
$GLGSV,2,2,05,81,15,27,37,1*71
$GAGSV,1,1,04,08,48,300,43,03,47,025,45,13,36,309,42,05,06,061,34,7*79
$GAGSV,1,1,04,08,48,300,43,03,47,025,47,13,36,309,43,05,06,061,33,1*7B
$GBGSV,5,1,17,12,80,182,47,24,64,5,51,7,58,355,44,3,57,205,45,1*7C
$GBGSV,5,2,17,1,54,141,44,34,52,211,49,9,48,230,45,10,47,316,42,1*79
```

\$GBGSV,5,3,17,26,44,100,47,16,39,207,43,4,38,117,41,2,37,240,41,1*77
 \$GBGSV,5,4,17,39,37,210,43,6,36,198,41,38,27,173,41,25,18,317,42,1*4E
 \$GBGSV,5,5,17,35,16,39,40,1*7F
 \$GBGSV,1,1,02,24,64,5,50,26,44,100,43,4*77

Table 8.1-9 GSV Data Format

Name	Example	Units	Description
Message ID	\$GPGSV		GSV protocol header GP=GPS/QZSS, GL=GLONSS, GA=GALILEO, GB=BEIDOU, GI=IRNSS.
Total number of messages	3		Range 1 to 9
Message number	1		Range 1 to 9
Satellites in view	09		
Satellite ID	8		Channel 1
Elevation	71	degrees	Channel 1 (Range 00 to 90)
Azimuth	268	degrees	Channel 1 (Range 000 to 359)
SNR (C/No)	47	dB-Hz	Channel 1 (Range 00 to 99, null when not tracking)
....		
Satellite ID	4		Channel 4 (Range 01 to 196)
Elevation	41	degrees	Channel 4 (Range 00 to 90)
Azimuth	237	degrees	Channel 4 (Range 000 to 359)
SNR (C/No)	46	dB-Hz	Channel 4 (Range 00 to 99, null when not tracking)
Signal ID	1		GPS/QZSS: L1 C/A=1, L5Q=8 GLONASS: L1 C/A=1 GALILEO: E1=7, E5a=1 BEIDOU: B1=1, B2a=4 IRNSS: L6=1
Checksum	*54		

- **RMC---Recommended Minimum Specific GNSS Data**

Table 8.1-10 contains the values for the following example:

\$GNRMC,015924.000,A,2503.71417,N,12138.74623,E,0.1,0.0,230217,,D*77

Table 8.1-10 RMC Data Format

Name	Example	Units	Description
Message ID	\$GNRMC		RMC protocol header
UTC Time	015924.000		hhmmss.sss
Status	A		A=data valid, D=differential data, V=data invalid
Latitude	2503.71417		ddmm.mmmmm
N/S Indicator	N		Latitude Direction: North or South

Longitude	12138.74623		dddmm.mmmmm
E/W Indicator	E		Longitude Direction: East or West
Speed over ground	0.1	knots	Speed over ground in knots
Course over ground	0.0	degrees	
Date	230217		ddmmyy
Magnetic variation		degrees	
Variation sense			Magnetic Variation Direction: East or West
Mode	D		A = Autonomous mode, D = Differential mode, E = Estimated (Dead Reckoning) mode, N=Data invalid
Checksum	*77		
<CR> <LF>			End of message termination

- **VTG---Course Over Ground and Ground Speed**

Table 8.1-11 contains the values for the following example:

\$GNVTG,0.0,T,,M,0.1,N,0.1,K,D*16

Table 8.1-11 VTG Data Format

Name	Example	Units	Description
Message ID	\$GNVTG		VTG protocol header
Course over ground	0.0	degrees	Reference to “true” earth poles
Reference	T		Indicates “terrestrial”
Course over ground		degrees	Reference to “magnetic” earth poles
Reference	M		Indicates “Magnetic”
Speed over ground	0.1	knots	Speed over ground in knots
Units	N		Indicates “Knots”
Speed over ground	0.1	km/h	Speed over ground in kilometers per hour
Units	K		Indicates “Kilometers per hour”
Mode	D		A = Autonomous mode, D = Differential mode, E = Estimated (Dead Reckoning)mode
Checksum	*16		
<CR> <LF>			End of message termination

8.2 Proprietary input/output message

Table 8.2-1 The table below summarizes the set of proprietary command sets for the RTK-1722-T

Software command	Command descriptions
\$PAIR006*3C<CR><LF>	Perform a Cold start
\$PAIR005*3F<CR><LF>	Perform a Warm start
\$PAIR004*3E<CR><LF>	Perform a Hot start

- **\$PAIR006*3C** : Perform a COLD start.
Command : \$PAIR006*3C<CR><LF>
Success Response: \$PAIR001,006,0*3D<CR><LF>
- **\$PAIR005*3F** : Perform a WARM start
Command : \$PAIR005*3F<CR><LF>
Success Response: \$PAIR001,005,0*3E<CR><LF>
- **\$PAIR004*3E** : Perform a HOT start
Command : \$PAIR004*3E<CR><LF>
Success Response: \$PAIR001,004,0*3F<CR><LF>

9 Recommended soldering reflow profile

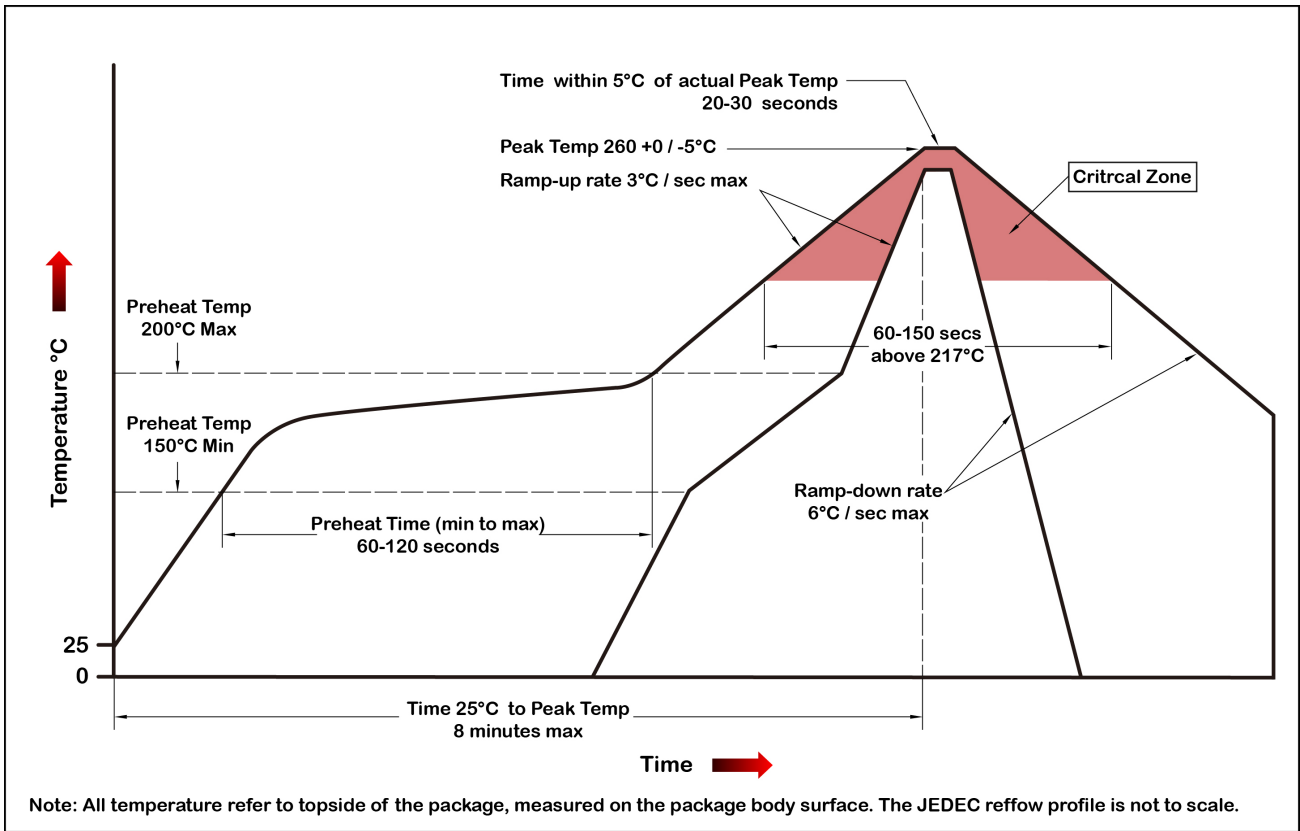

Note: The RTK-1722-T module should be soldered on the topside in the soldering process to prevent from falling down.

10 Reel Packing information

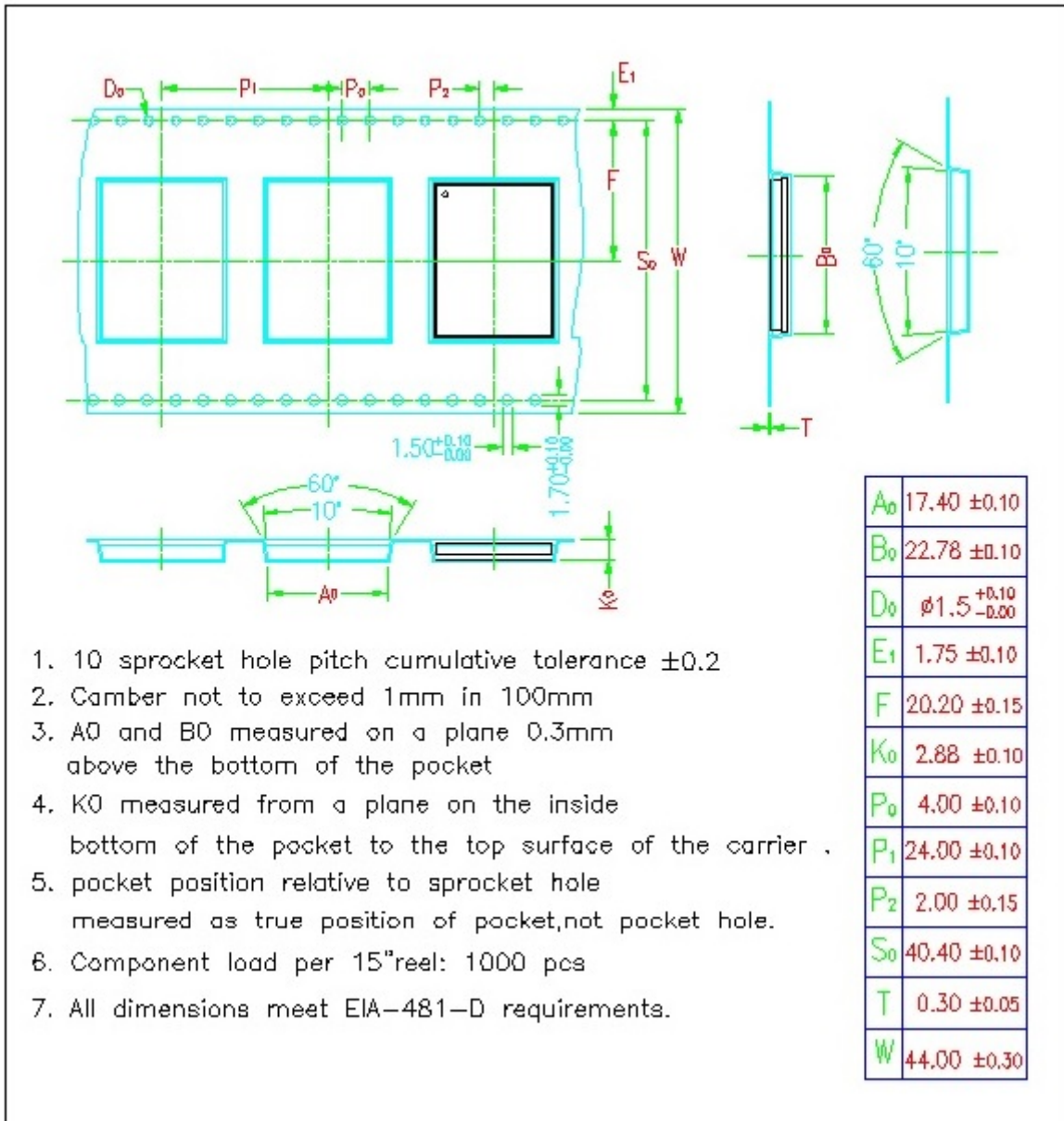

11 Packing and Handling

GNSS modules, like any other SMD devices, are sensitive to moisture, electrostatic discharge, and temperature. By following the description sketched in the document for LOCOSYS GNSS module storage and handling, it is possible to reduce the chances of them being damaged during production.

11.1 Packing

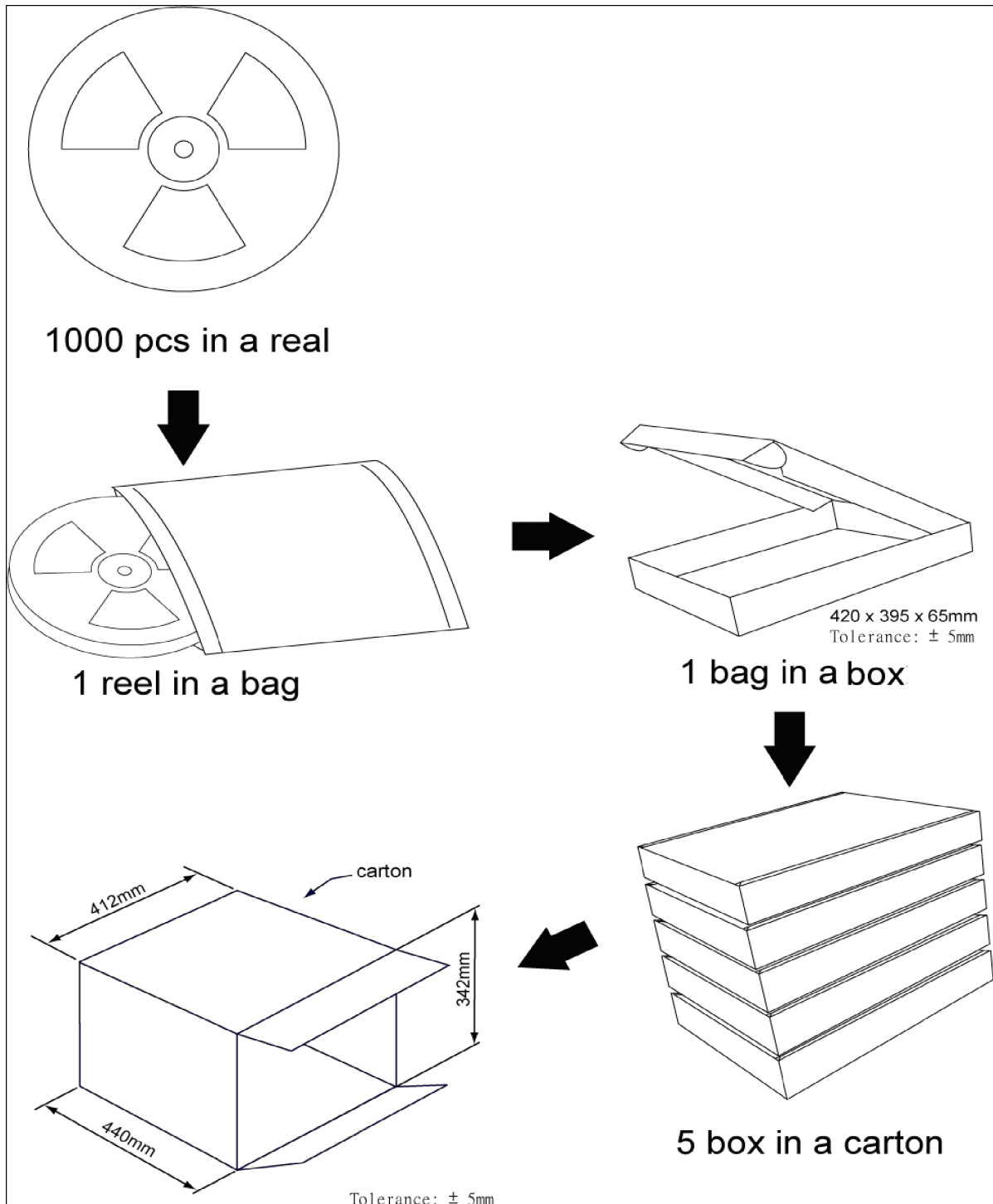

11.2 Moisture Sensitivity

The module belongs to moisture sensitive device (IPC/JEDEC J-STD-020C Level III). If it is not used by then, we strong recommended storing the GNSS modules in dry places such as dry cabinet. The approximate shelf life for LOCOSYS GNSS modules packages is 6 months from the bag seal date, when store in a non-condensing storage environment (<30°C/60% RH)

11.3 ESD Handling



Please carefully follow the following precautions to prevent severe damage to GNSS modules.

LOCOSYS GNSS modules are sensitive to electrostatic discharges, and thus are Electrostatic Sensitive Devices (ESD). Careful handling of the GNSS modules and in particular RFIN pin must follow the standard ESD safety protections:

- Unless there is a galvanic coupling between the local GND and the PCB GND, then the first point of contact when handling the PCB shall always be between the local GND and PCB GND.
- Before working with RFIN pin, please make sure the GND is connected.
- When working with RFIN pin, do not contact any charges capacitors or materials that can easily develop or store charges such as patch antenna, coax cable, soldering iron.
- When soldering RFIN pin, please make sure to use an ESD safe soldering iron (tip).

12 Reference Circuits

- GNSS based timing solution for O-RAN

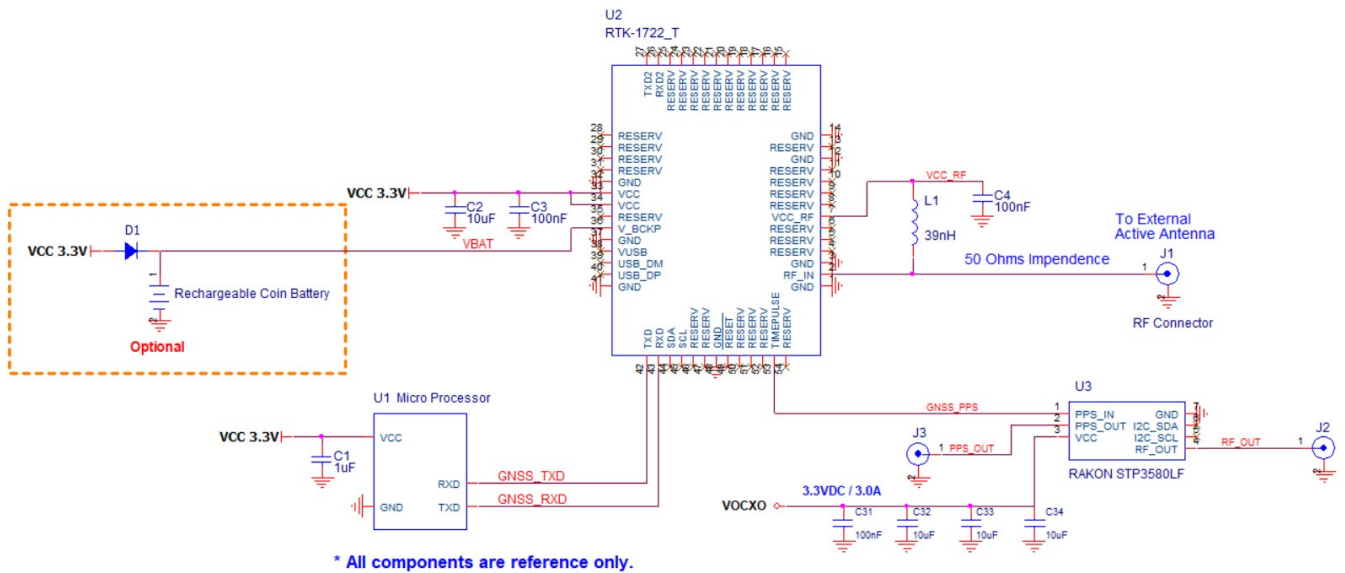

- External active antenna supply power from RTK-1722_T pin 7 (VCC_RF)

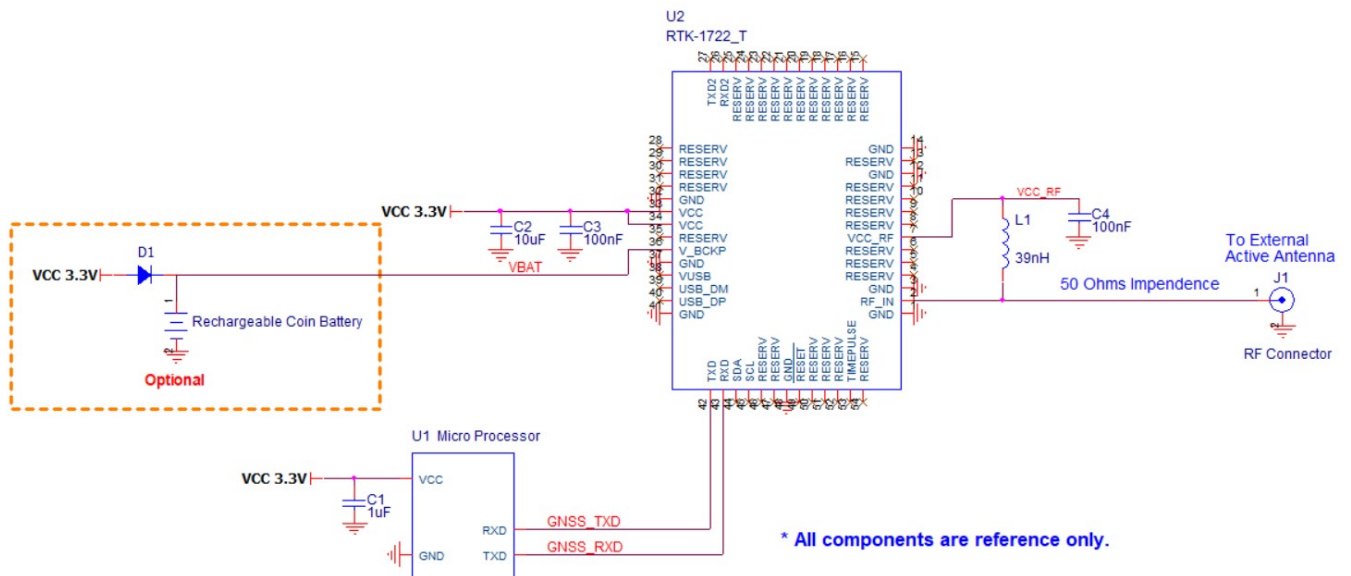

- External active antenna supply power from user

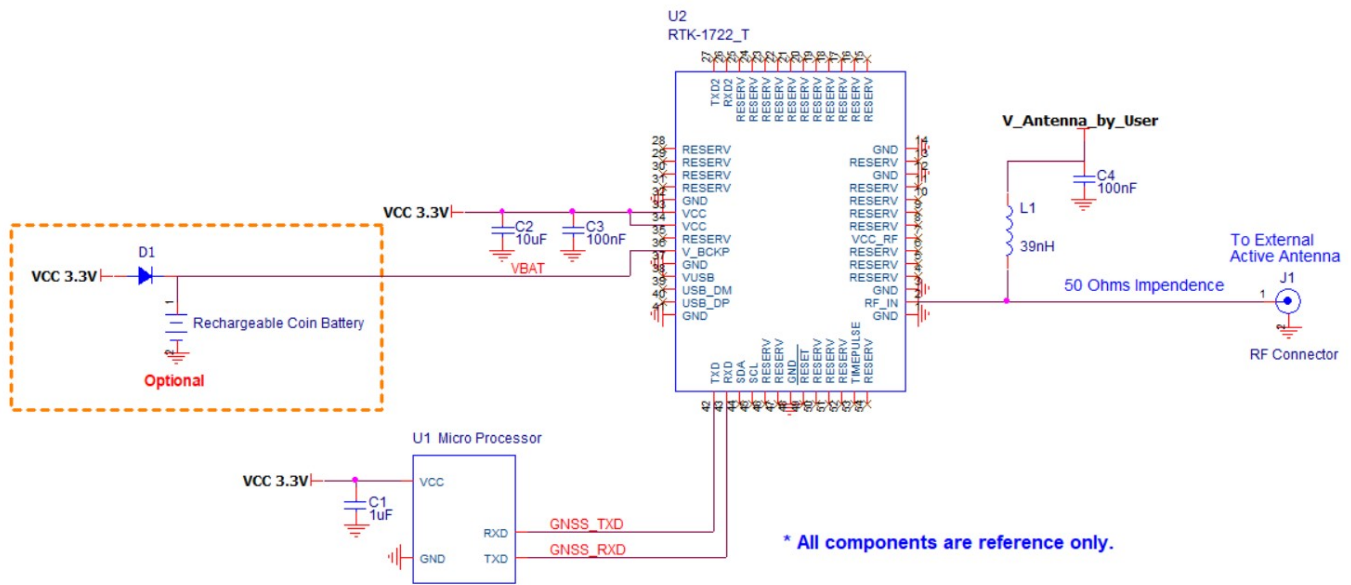

Document change list

Revision 0.1

- Draft release on March 23, 2022.