

Product name	Description	Version
RTK-1612	Dual-frequency multi-constellation GNSS RTK module	1.3



1 Introduction

The RTK-1612 is a high-performance dual-band GNSS RTK module that designed for applications requiring centimeter level positioning accuracy. It adopts 12 nm process and integrate efficient power management architecture to perform low power and high sensitivity. The module supports concurrent reception of GPS, GLONASS, BeiDou, GALILEO, and QZSS to improve the availability and reliability of RTK solution even in the harsh environment.

2 Features

- Dual-frequency and multi-constellation RTK positioning solution
- Support GPS, GLONASS, GALILEO, BEIDOU and QZSS
- Capable of SBAS (WAAS, EGNOS, MSAS, GAGAN)
- Support 135-channel GNSS
- Low power consumption
- Fast TTFF at low signal level
- Up to 10 Hz update rate
- Small form factor 16 x 12.2 x 2.4 mm
- SMD type with stamp holes; RoHS compliant
- AEC-Q104 compliant
- IATF 16949 quality control

3 Application

- Precision Agriculture
- AGV Robotics
- V2X / ETC / 5G Station
- Structural / Land Monitoring
- Offshore / Marine Application

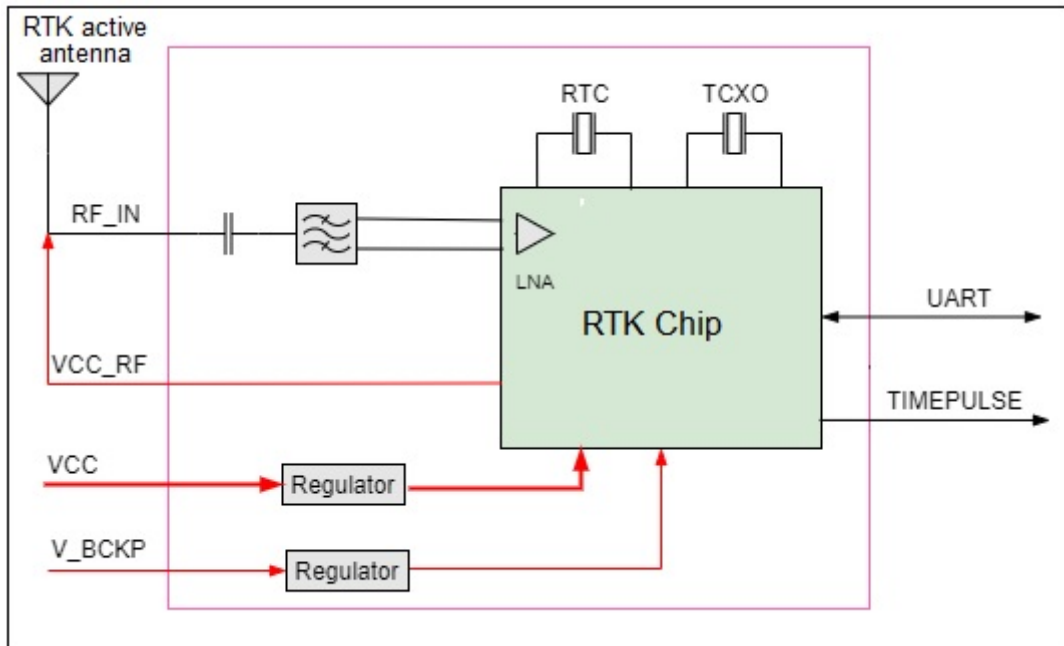

Fig 3-1 System block diagram.

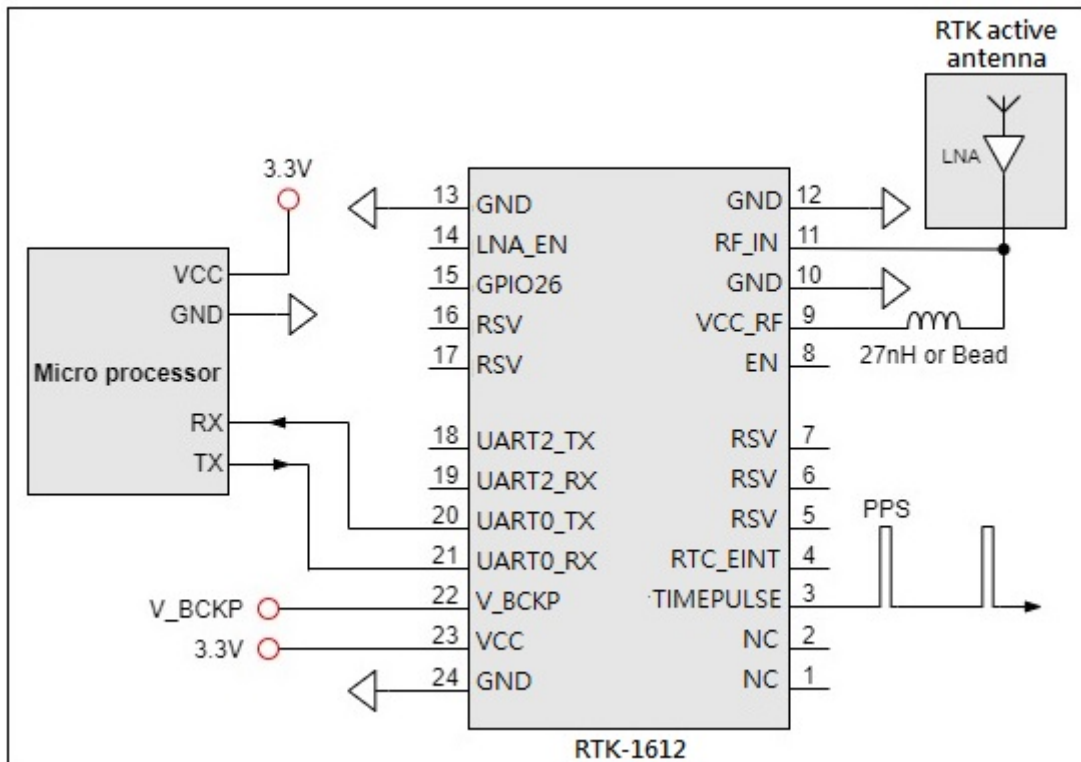
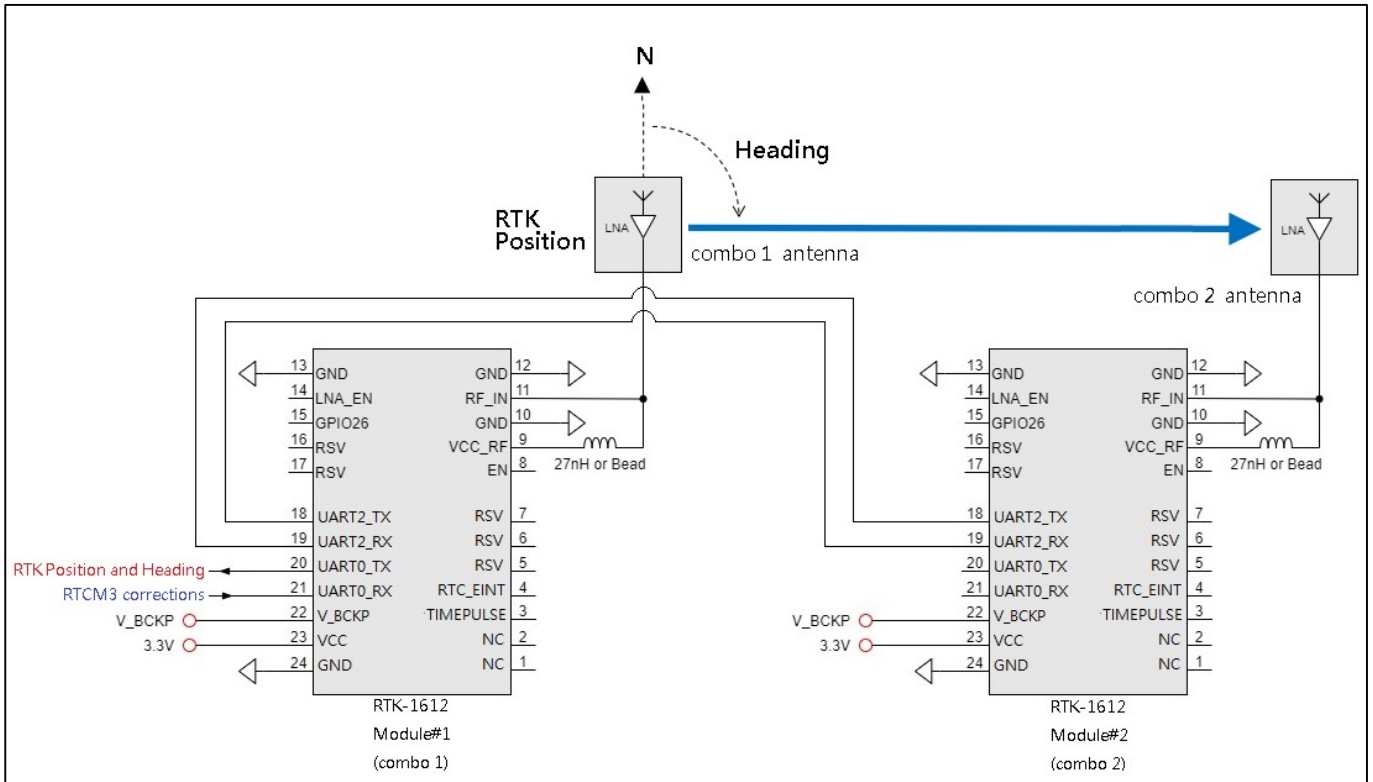

Fig 3-2 Typical application circuit that uses an active antenna



Refer to the application note "Heading application notes for RTK-1612"

Fig 3-3 RTK-1612 (Position & Orientation) Reference Layout Guide

4 GNSS receiver

Frequency	GPS/QZSS: L1 C/A, L5C GLONASS: L1OF GALILEO: E1, E5a BEIDOU: B1I, B2a	
Channels	Support 135 channels	
Update rate	1Hz default, up to 10Hz	
Sensitivity	Tracking	-165dBm (with external LNA)
	Cold start	-148dBm (with external LNA)
Acquisition Time	Cold start (open sky)	28s (typical)
	RTK Convergence time	< 10s (typical; after 3D fix)
Position Accuracy ⁽¹⁾	Autonomous	1.5m CEP
	RTK ⁽²⁾	0.01m + 1ppm (Horizontal) CEP
Max. Altitude	< 18,000 m	
Max. Velocity	< 500 m/s	
Protocol Support	NMEA 0183 ver. 4.1	115200 bps ⁽³⁾ , 8 data bits, no parity, 1 stop bits (default) 1Hz : GGA, GLL, RMC 0.2Hz : GSA,GSV
	Raw data	115200 bps, RTCM V3.3, MSM4, MSM5 and MSM7, message type 1005, 1074, 1075, 1077, 1084, 1085, 1087, 1094, 1095, 1097, 1114, 1115, 1117, 1124, 1125, 1127

Note 1: Open sky, dual band, demonstrated with a good external LNA.

Note 2: CEP, 24hr static.

Note 3: Both baud rate output message rate are configurable to be factory default.

5 Software interface

5.1 NMEA output message

Table 5.1-1 NMEA output message

NMEA record	Description
GGA	Global positioning system fixed data
GLL	Geographic position - latitude/longitude
GSA	GNSS DOP and active satellites
GSV	GNSS satellites in view
RMC	Recommended minimum specific GNSS data

● **GGA--- Global Positioning System Fixed Data**

Table 5.1-2 contains the values for the following example:

\$GNGGA,061730.000,2503.7135400,N,12138.7466600,E,1,46,0.49,131.36,M,15.32,M,,*71

Table 5.1- 2 GGA Data Format

Name	Example	Units	Description
Message ID	\$GNGGA		GGA protocol header
UTC Time	061730.000		hhmmss.sss
Latitude	2503.7135400		ddmm.mmmmmmm
N/S indicator	N		N=north or S=south
Longitude	12138.7466600		dddmm.mmmmmmm
E/W Indicator	E		E=east or W=west
Position Fix Indicator	1		See Table 5.1-3
Satellites Used	46		Number of satellites in use
HDOP	0.49		Horizontal Dilution of Precision (meters)
MSL Altitude	131.36	meters	Antenna Altitude above/below mean-sea-level (geoid) (in meters)
Units	M	meters	Units of antenna altitude, meters
Geoidal Separation	15.32	meters	
Units	M	meters	Units of geoidal separation, meters
Age of diff. GNSS data		second	Null fields when DGPS is not used
Diff. Ref. Station ID			Differential reference station ID, 0000-1023
Checksum	*71		Checksum
<CR> <LF>			End of message termination

Table 5.1-3 Position Fix Indicators

Value	Description
0	No position fix
1	Autonomous GNSS fix

2	Differential GNSS fix
4	RTK fixed
5	RTK float
6	Estimated/Dead reckoning fix

● **GLL--- Geographic Position – Latitude/Longitude**

Table 5.1-4 contains the values for the following example:

\$GNGLL,2503.7135400,N,12138.7466600,E,061730.000,A,A*48

Table 5.1-4 GLL Data Format

Name	Example	Units	Description
Message ID	\$GNGLL		GLL protocol header
Latitude	2503.7135400		ddmm.mmmmmmm
N/S indicator	N		N=north or S=south
Longitude	12138.7466600		dddmm.mmmmmmm
E/W indicator	E		E=east or W=west
UTC Time	061730.000		hhmmss.sss
Status	A		A=data valid or V=data not valid
Mode	A		N = No position fix A = Autonomous GNSS fix D = Differential GNSS fix R = RTK fixed F = RTK float E = Estimated/Dead reckoning fix
Checksum	*48		
<CR> <LF>			End of message termination

● **GSA---GNSS DOP and Active Satellites**

Table 5.1-5 contains the values for the following example:

\$GNGSA,A,3,11,195,194,199,08,07,01,27,16,09,23,,1.19,0.64,1.00,1*3F

\$GNGSA,A,3,87,81,76,,,,,,,,,1.19,0.64,1.00,2*0F

\$GNGSA,A,3,,,,,,,,,,,,,1.19,0.64,1.00,3*09

\$GNGSA,A,3,34,24,12,07,11,10,08,38,25,09,13,16,1.19,0.64,1.00,4*02

Table 5.1-5 GSA Data Format

Name	Example	Units	Description
Message ID	\$GNGSA		GSA protocol header
Mode 1	A		See Table 5.1-6
Mode 2	3		See Table 5.1-7

ID of satellite used	11		SV on Channel 1
ID of satellite used	195		SV on Channel 2
....		
ID of satellite used			SV on Channel 12
PDOP	1.19		Position Dilution of Precision
HDOP	0.64		Horizontal Dilution of Precision
VDOP	1.00		Vertical Dilution of Precision
GNSS system ID	4		See Table 5.1-8
Checksum	*3F		
<CR> <LF>			End of message termination

Table 5.1-6 Mode 1

Value	Description
M	Manually set to operate in 2D or 3D mode
A	Automatically switching between 2D or 3D mode

Table 5.1-7 Mode 2

Value	Description
1	No position fix
2	2D fix
3	3D fix

Table 5.1-8 GNSS system ID

Value	Description
1	GPS
2	GLONASS
3	GALILEO
4	BEIDOU
6	IRNSS

● GSV---GNSS Satellites in View

Table 5.1-9 contains the values for the following example:

```
$GPGSV,3,1,09,8,71,268,47,27,63,18,49,11,44,191,46,4,41,237,46,1*54
$GPGSV,3,2,09,16,38,42,42,9,32,279,39,26,22,70,38,31,15,131,36,1*56
$GPGSV,3,3,09,7,15,320,40,1*6B
$GPGSV,1,1,04,8,71,268,50,27,63,18,49,9,32,279,43,26,22,70,42,8*6C
$GLGSV,2,1,05,82,63,47,47,83,56,182,36,80,47,9,42,79,33,85,45,1*71
$GLGSV,2,2,05,81,15,27,37,1*71
$GAGSV,1,1,04,08,48,300,43,03,47,025,45,13,36,309,42,05,06,061,34,7*79
$GAGSV,1,1,04,08,48,300,43,03,47,025,47,13,36,309,43,05,06,061,33,1*7B
```

\$GBGSV,5,1,17,12,80,182,47,24,64,5,51,7,58,355,44,3,57,205,45,1*7C
 \$GBGSV,5,2,17,1,54,141,44,34,52,211,49,9,48,230,45,10,47,316,42,1*79
 \$GBGSV,5,3,17,26,44,100,47,16,39,207,43,4,38,117,41,2,37,240,41,1*77
 \$GBGSV,5,4,17,39,37,210,43,6,36,198,41,38,27,173,41,25,18,317,42,1*4E
 \$GBGSV,5,5,17,35,16,39,40,1*7F
 \$GBGSV,1,1,02,24,64,5,50,26,44,100,43,4*77

Table 5.1-9 GSV Data Format

Name	Example	Units	Description
Message ID	\$GPGSV		GSV protocol header GP=GPS/QZSS, GL=GLONSS, GA=GALILEO, GB=BEIDOU, GI=IRNSS.
Total number of messages	3		Range 1 to 9
Message number	1		Range 1 to 9
Satellites in view	09		
Satellite ID	8		Channel 1
Elevation	71	degrees	Channel 1 (Range 00 to 90)
Azimuth	268	degrees	Channel 1 (Range 000 to 359)
SNR (C/No)	47	dB-Hz	Channel 1 (Range 00 to 99, null when not tracking)
....		
Satellite ID	4		Channel 4 (Range 01 to 196)
Elevation	41	degrees	Channel 4 (Range 00 to 90)
Azimuth	237	degrees	Channel 4 (Range 000 to 359)
SNR (C/No)	46	dB-Hz	Channel 4 (Range 00 to 99, null when not tracking)
Signal ID	1		GPS/QZSS: L1 C/A=1, L5Q=8 GLONASS: L1 C/A=1 GALILEO: E1=7, E5a=1 BEIDOU: B1=1, B2a=4 IRNSS: L6=1
Checksum	*54		
<CR> <LF>			End of message termination

● **RMC---Recommended Minimum Specific GNSS Data**

Table 5.1-10 contains the values for the following example:

\$GNRMC,061730.000,A,2503.7135400,N,12138.7466600,E,0.01,0.00,230522,,A,V*00

Table 5.1-10 RMC Data Format

Name	Example	Units	Description
Message ID	\$GNRMC		RMC protocol header

UTC Time	061730.000		hhmmss.sss
Status	A		A = Autonomous V = invalid D = Differential
Latitude	2503.7135400		ddmm.mmmmmmm
N/S Indicator	N		N=north or S=south
Longitude	12138.7466600		dddmm.mmmmmmm
E/W Indicator	E		E=east or W=west
Speed over ground	0.01	knots	True
Course over ground	0.00	degrees	
Date	230522		ddmmyy
Magnetic variation		degrees	
Variation sense			E=east or W=west
Mode	A		N = No position fix A = Autonomous GNSS fix D = Differential GNSS fix R = RTK fixed F = RTK float E = Estimated/Dead reckoning fix
Navigational status indicator	V		S = Safe C = Caution U = Unsafe V = Void
Checksum	*00		
<CR> <LF>			End of message termination

5.2 Proprietary commands

5.2.1 Query firmware version

Synopsis:

```
$PLSC,VER*CK<CR><LF>
```

Response:

```
$PLSR,<VER>,<ID>,<VER>,<LIBRARY>,<RSV>*CK<CR><LF>
```

Parameter	Description
ID	Firmware ID
VER	Firmware version
LIBRARY	RTK core library version

RSV	Reserved
-----	----------

Examples:

```
$PLSR,VER,RTK35X,V1.1X0314AS,Lib20210517,0<CR><LF>
```

5.2.2 Set up module as a reference station or as a rover

Synopsis:

```
$PLSC,MCBASE,<MODE>*CK<CR><LF>
```

Response:

```
$PLSR,MCBASE,<MODE>*CK<CR><LF>
```

Parameter	Format	Description
MODE	Decimal	0: set up the board as a rover(default) 1: set up the board as a reference station (Output RTCM3.3 1005, 1074, 1084, 1094, 1124 messages) -1: base location not set yet

Examples:

```
$PLSC,MCBASE,1*26<CR><LF>
```

5.2.3 Set the base location (reference position)

Synopsis:

```
$PLSC,SETBASEXYZ,<X>,<Y>,<Z>*CK<CR><LF>
```

Response:

```
$PLSR,BASEXYZ,<X>,<Y>,<Z>*CK<CR><LF>
```

Parameter	Format	Description
X	DDDDDDD.DDD	WGS-84 ECEF X-axis coordinate (in meters)
Y	DDDDDDD.DDD	WGS-84 ECEF Y-axis coordinate (in meters)
Z	DDDDDDD.DDD	WGS-84 ECEF Z-axis coordinate (in meters)

Examples:

```
$PLSC,SETBASEXYZ,-3028442.081,4923062.884,2687870.875*03<CR><LF>
```

5.2.4 Get the base location setting

Synopsis:

```
$PLSC,GETBASEXYZ*CK<CR><LF>
```

Response:

```
$PLSR,BASEXYZ,<X>,<Y>,<Z>*CK<CR><LF>
```

Parameter	Format	Description
-----------	--------	-------------

X	DDDDDDDD.DDD	WGS-84 ECEF X-axis coordinate (in meters)
Y	DDDDDDDD.DDD	WGS-84 ECEF Y-axis coordinate (in meters)
Z	DDDDDDDD.DDD	WGS-84 ECEF Z-axis coordinate (in meters)

Note: If the vale = 0, means base location not set yet.

Examples:

```
$PLSC,SETBASEXYZ,-3028442.081,4923062.884,2687870.875*03<CR><LF>
```

5.2.5 Set up the output data update rate, in Hz.(included 1, 5, 10)

Synopsis:

```
$PLSC, FIXRATE,<FIXRATE>*CK<CR><LF>
```

Response:

```
$PLSR, FIXRATE,<FIXRATE>*CK<CR><LF>
```

Parameter	Format	Description
FIXRATE	Decimal	1: set up the fix rate as 1Hz (default) 5: set up the fix rate as 5Hz 10: set up the fix rate as 10Hz

Examples:

```
$PLSC, FIXRATE,5*6C <CR><LF>
```

5.2.6 Get the setting of output data update rate

Synopsis:

```
$PLSC, FIXRATE,?*CK<CR><LF>
```

Response:

```
$PLSR, FIXRATE,<RATE1>,<RATE2>,<RATE3>*CK<CR><LF>
```

Parameter	Format	Description
RATE1	Decimal	Present update rate
RATE2	Decimal	Default update rate
RATE3	Decimal	Maximum update rate

5.2.7 Set up the GST message output

Synopsis:

```
$PAIR062,8,<OUTPUT_MODE>*CS<CR><LF>  
$PAIR513*CS<CR><LF>
```

Parameter	Format	Description
OUTPUT_MODE	Decimal	0: disable \$GNGST output (default)

		1: enable \$GNGST output
--	--	--------------------------

Examples:

```
$PAIR062,8,1*37 <CR><LF>
```

Note: Changing fix rate from 1Hz to 5Hz will reset configuration to factory default settings.

- **GST --- Estimated Position Error**

Table 5.2-1 contains the values for the following example:

```
$GNGST,021423.000,1.8,2.1,1.6,105.9,1.6,2.0,6.8*74
```

Table 5.2-1 GST Data Format

Name	Example	Units	Description
Message ID	\$GNGST		GST protocol header
UTC Time	021423.000		hhmmss.sss
RMS value of the standard deviation of the ranges	1.8		
Standard deviation of semi-major axis of error ellipse	2.1	meters	0~9999999.99
Standard deviation of semi-minor axis of error ellipse	1.6	meters	0~9999999.99
Orientation of semi-major axis of error ellipse	105.9	degree	
Standard deviation of Latitude error	1.6	meters	
Standard deviation of Longitude error	2.0	meters	
Standard deviation of altitude error	6.8	meters	
Checksum	*74		
<CR> <LF>			End of message termination

5.2.8 Set up the PLSV message output

Synopsis:

```
$PLSC,MSG,<OUTPUT_MODE>*CS<CR><LF>
$PLSC,SMSG*CS<CR><LF>
```

Parameter	Format	Description
OUTPUT_MODE	Decimal	0: disable \$PLSV output (default) 4000: enable \$PLSV output

Examples:

```
$PLSC,MSG,4000*51 <CR><LF>
$PLSC,SMSG*2A<CR><LF>
```

- **PLSV --- 3D velocity & deviation information**

Table 5.2-2 contains the values for the following example:

```
$PLSV,0,0,0,12,12,10*28
```

Table 5.2-2 PLSV Data Format

Name	Example	Units	Description
Message ID	\$PLSVD		PLSVD protocol header
True east velocity	0	cm/s	-51500~51500
True north velocity	0	cm/s	-51500~51500
True down velocity	0	cm/s	-10000~10000
Deviation of east velocity	12	cm/s	
Deviation of north velocity	12	cm/s	
Deviation of down velocity	10	cm/s	
Checksum			
<CR> <LF>			

5.2.9 Set up the NMEA message output

Synopsis:

```
$PLSC,NMEA,<OUTPUT_MODE>*CS<CR><LF>
```

Parameter	Format	Description
OUTPUT_MODE	Decimal	FF: enable NMEA message output (default) 0: disable NMEA message output

Examples:

```
$PLSC,NMEA,FF*0B <CR><LF>
```

```
$PLSC,NMEA,0*3B <CR><LF>
```

6 Pin assignment and descriptions



Table 6-1 Pin descriptions

Pin #	Name	Type	Description	Note
1	NC		Not connect	
2	NC		Not connect	
3	TIMEPULSE	O	Time pulse (PPS, default 100 ms pulse/sec when GNSS fix is available. Output high level is 1.8V)	
4	RTC_EINT	I	RTC external interrupt	
5	RESERVED	I/O	Leave this pin floating	
6	RESERVED	I/O	Leave this pin floating	
7	RESERVED	I	Leave this pin floating	
8	EN	I	Enable the module, high active. Internal 10K ohm pull-up resistor to 1.8V. Setting this pin to low will disable “hot start” function, i.e. boot from “cold start” . Leave	

			unconnected if not used.	
9	VCC_RF	O	Output voltage for active antenna	
10	GND	P	Ground	
11	RF_IN	I	GNSS RF signal input. The overall gain of the active antenna must be between 8dB ~ 25dB.	
12	GND	P	Ground	
13	GND	P	Ground	
14	LNA_EN	O	Output pin to control the external LNA, high active. Internal pull down.	
15	GPIO26	I/O	General purpose I/O	
16	RSV		Reserved pin. Leave unconnected.	
17	RSV		Reserved pin. Leave unconnected.	
18	UART2_TX	O	Serial output	1
19	UART2_RX	I	Serial input	1
20	UART0_TX	O	Serial output	
21	UART0_RX	I	Serial input	
22	V_BCKP	P	Backup battery input. It is recommended to connect a backup supply voltage to V_BCKP in order to enable warm and hot start features. Moreover, V_BCKP is a must of the system running. If no backup power is available, connect V_BCKP to the main power supply (VCC).	
23	VCC	P	DC supply input. Must be clean and stable.	2
24	GND	P	Ground	

<Note>

- 1.8V LVTTTL serial port
- If an abnormal input voltage as shown in the figure below is input, even if the correct voltage is input again later, the module may not work until V_BCKP pin is re-powered.

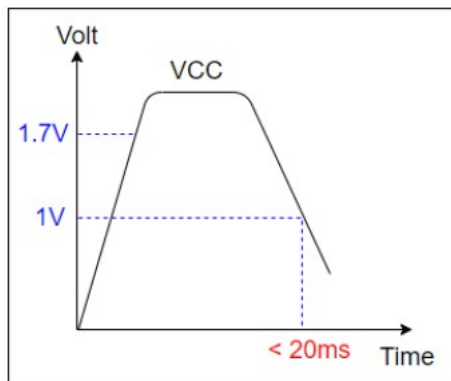

7 DC & Temperature characteristics

7.1 Absolute maximum ratings

Parameter	Symbol	Ratings	Units
DC Supply Input Voltage	VCCabs	5.5	V
Input Backup Battery Voltage	V_BCKPabs	5.5	V
Operating Temperature Range	Topr_abs	-40 ~ 85	°C
Storage Temperature Range	Tstg_abs	-40 ~ 85	°C

7.2 DC Electrical characteristics

Parameter	Symbol	Conditions	Min.	Typ.	Max.	Units
DC Supply Input Voltage	VCC		3.1	3.3	4.5	V
Input Backup Battery Voltage	V_BCKP		2.0		4.5	V
VCC_RF Output Voltage	VCC_RF			VCC		V
Supply Current ^{(1),(2)}	I _{ss}	VCC = 3.3V, w/o active antenna, Tracking		65		mA
	I _{shdn}	VCC=3.3V, EN=0V		23		uA
Backup Battery Current	I _{bat}	VIN = 0V		64		uA
VCC_RF Output Current	I _{out}	VIN = 3.3V			30	mA
High Level Input Voltage	V _{IH}	For UART0_TX, UART0_RX	2.2		3.6	V
Low Level Input Voltage	V _{IL}		-0.3		0.8	V
High Level Output Voltage	V _{OH}		2.18		3.3	V
Low Level Output Voltage	V _{OL}				0.4	V
High Level Input Voltage	V _{IH}	For TIMEPULSE, RTC_EINT,EN, LNA_EN, GPIO26 UART2_TX UART2_RX	1.21		1.98	V
Low Level Input Voltage	V _{IL}		-0.3		0.6	V
High Level Output Voltage	V _{OH}		1.29		1.98	V
Low Level Output Voltage	V _{OL}				0.45	V

Note 1: Measured when RTK FIX is available, input voltage is 3.3V.

Note 2: The inrush current that occurs at the first power-on or “full cold start” command can be as high as 600mA for 20 μs.

7.3 Temperature characteristics

Parameter	Symbol	Min.	Typ.	Max.	Units
Operating Temperature	Topr	-40	-	85	°C
Storage Temperature	Tstg	-40	25	85	°C

8 Mechanical specification

8.1 Outline dimensions

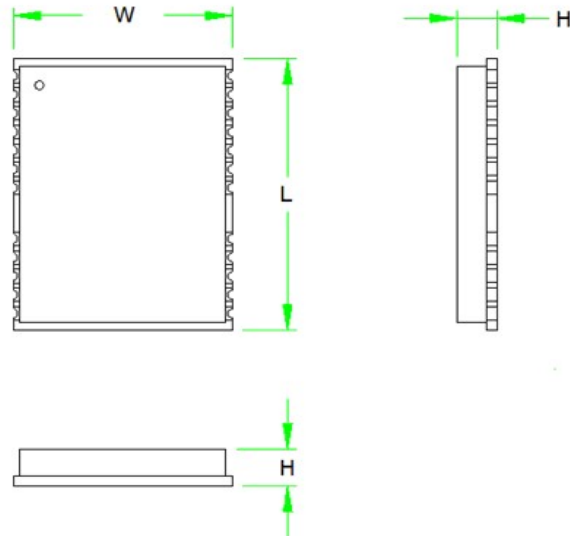

Symbol	Min. (mm)	Typ. (mm)	Max. (mm)
W	12.1	12.2	12.3
L	15.7	16.0	16.4
H	2.2	2.4	2.6

8.2 Recommended land pattern dimensions

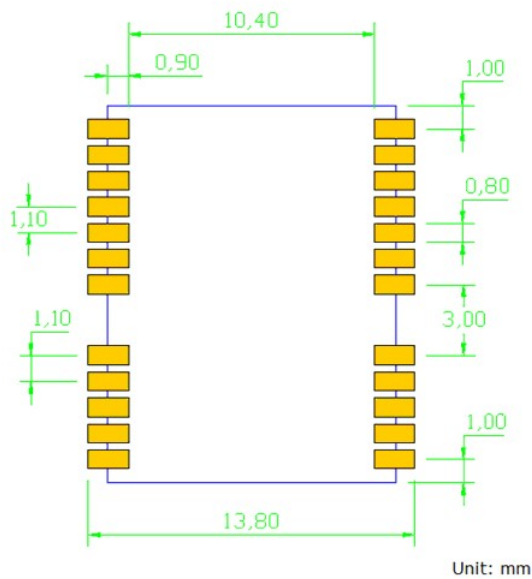

Note: The recommended land pattern dimensions are shown for reference only, as actual pad layouts may vary depending on application.

9 Reel Packing information

9.1 ESD precaution

GNSS modules are electrostatic sensitive devices. Handling the modules without proper ESD protection may result in severe damage to them. ESD protection must be implemented throughout the processing, handling and even when the modules are being returned for repair.

9.2 Packaging

The modules are sealed in a moisture barrier ESD bag with the appropriate units of desiccant and a humidity indicator card. It should not be opened until the modules are ready to be soldered onto the application.

9.2.1 Packaging

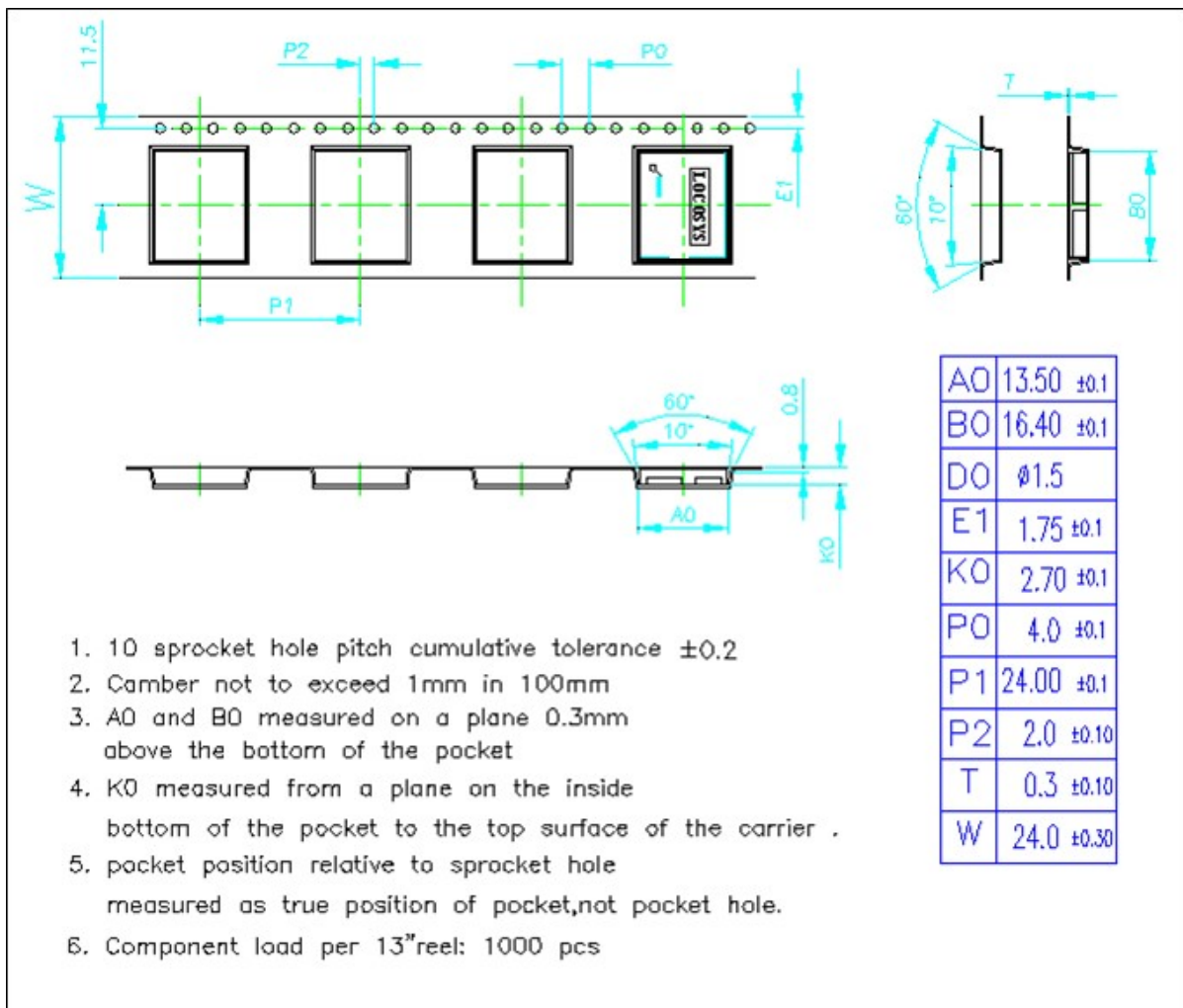

9.2.2 Box packaging

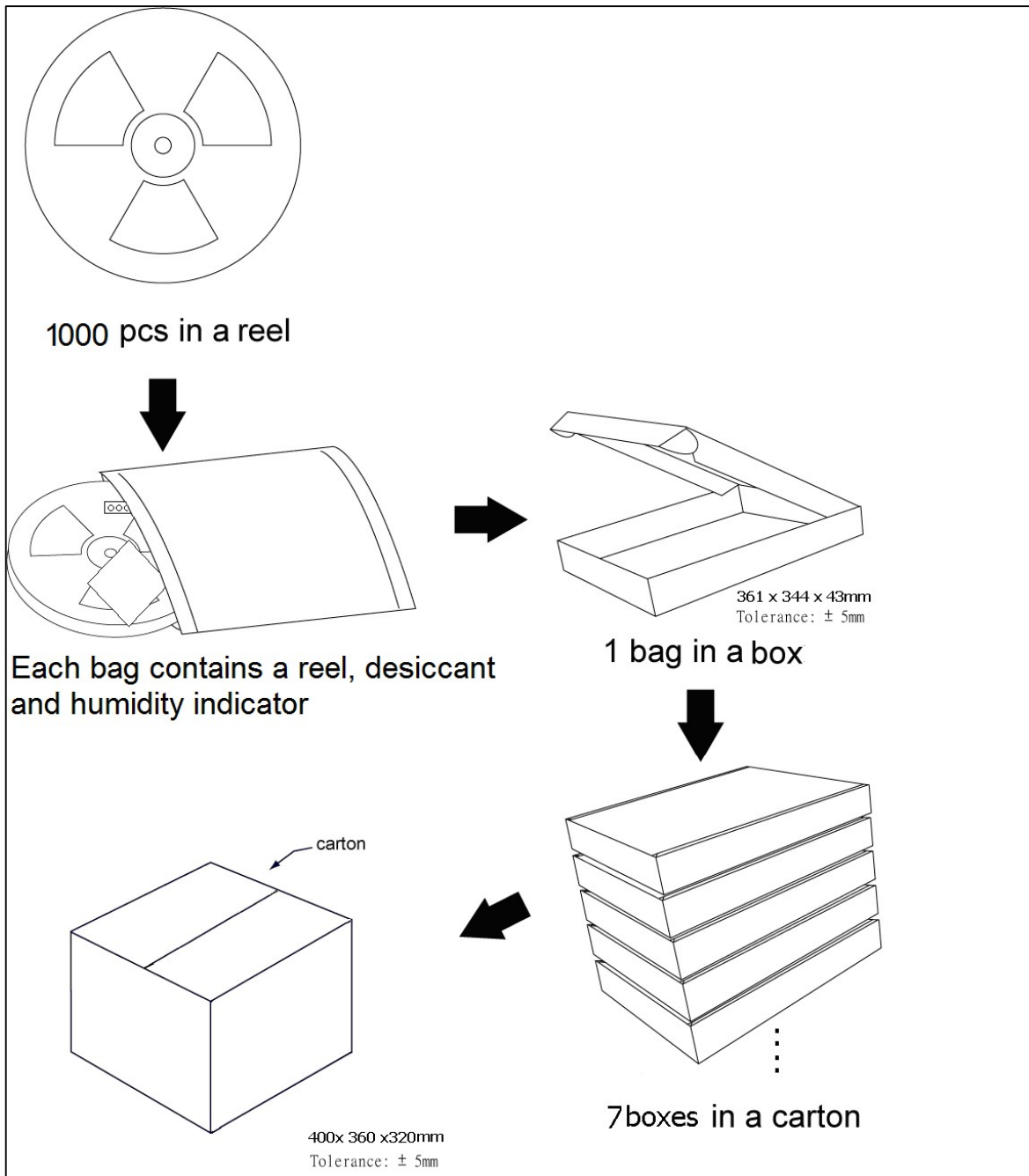

9.3 Moisture sensitivity level

The moisture sensitivity level of the module is 3. After the sealed bag is opened, modules should be mounted within 168 hours at factory conditions of $\leq 30^{\circ}\text{C}$ and 60% RH or stored at $\leq 20\%$ RH.

The modules require baking before mounting if above conditions are not met. If baking is required, the modules without the tape and reel may be baked for:

- a. 192 hours at $40^{\circ}\text{C} + 5^{\circ}\text{C} / -0^{\circ}\text{C}$ and $< 5\%$ RH
- b. 24 hours at $125^{\circ}\text{C} + 5^{\circ}\text{C} / -0^{\circ}\text{C}$

9.4 Reflow soldering

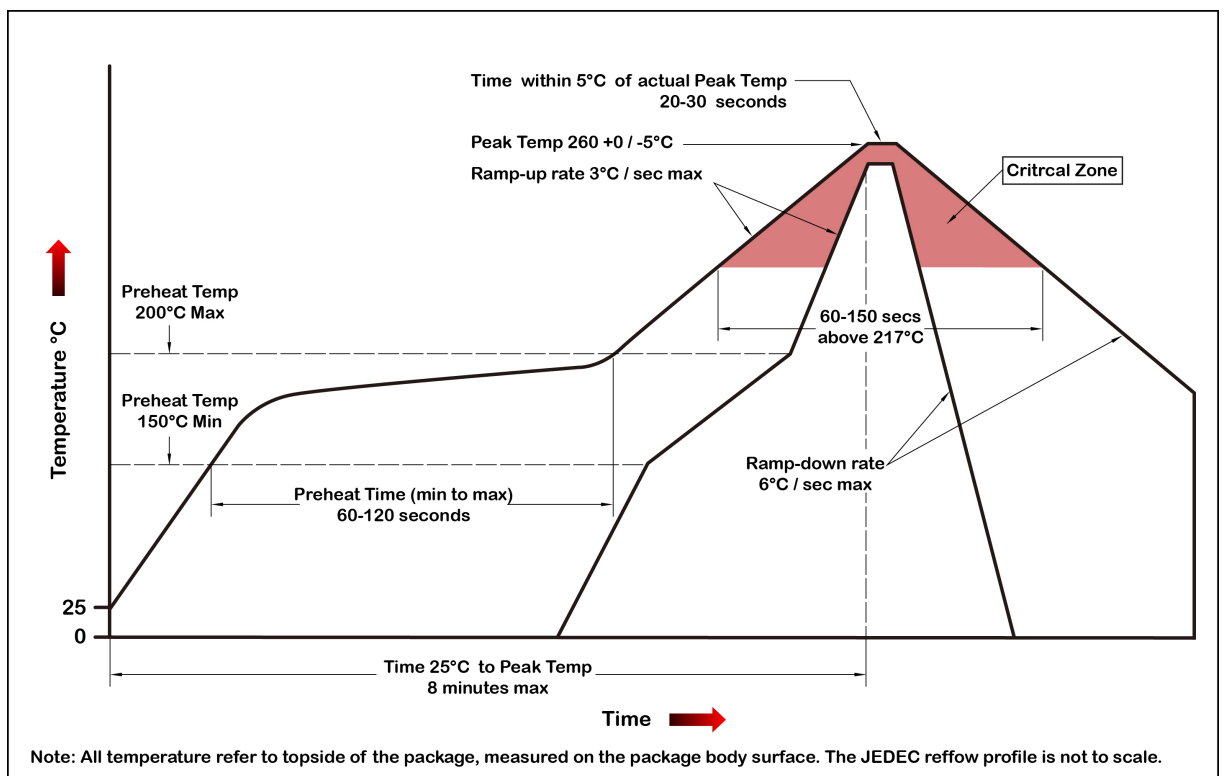

Note the module mounted to the top side (first reflow side) may fall off during reflow soldering of the bottom side.

10 Product marking and ordering information

10.1 Product marking

The marking of the module is engraved on the metal shielding that has product information, such as LOCOSYS logo, product name and manufacturing date.

Document change list

Revision 0.1

- Draft release on March 26, 2021.

Revision 0.2 (April 9, 2021)

- Revised the GSV default output from 1Hz to 0.2Hz in the section 4.
- Added proprietary commands of Set up the GST message output in the section 5.2.5.
- Added proprietary commands of Set up the PLSV message output in the section 5.2.6.

Revision 0.3 (September 9, 2021)

- Revised the Fig 3-2.
- Added the Fig 3-3.
- Add the description of up to 10 Hz update rate in section 2 and 4.
- Changed the max. velocity from 515 m/s to 500 m/s in section 4.
- Revised the GSA default output from 1Hz to 0.2Hz in the section 4.
- Removed the VTG default output in the section 4.
- Removed the description of VTG in section 5.1.
- Added the Proprietary commands of Set up the update rate 10Hz in the section 5.2.4.
- Revised the proprietary commands of Set up the PLSV message output in the section 5.2.6.
- Revised the Pin assignment and descriptions of pin18 to pin 21 in section 6.

Revision 0.4 (January 25, 2022)

- Changed the overall gain of the active antenna to be 8dB ~ 25dB in section 6.

Revision 0.5 (February 10, 2022)

- Revised the Fig 3-3.
- Revised NMEA RMC message in section 5.1.
- Revised proprietary commands in section 5.2.
- Revised the En pin description in section 6.
- Added notes of UART2_TX and UART2_RX and VCC pins in Table 6-1.
- Changed the backup battery current from 44uA to 64uA in section 7.2.
- Added IO voltage for RTC_EINT, GPIO26, UART2_TX, UART2_RX in section 7.2.
- Revised the reflow soldering profile in section 9.4

Revision 1.0 (April 19, 2023)

- Revised proprietary commands in section 5.2.1

Revision 1.1 (June 12, 2023)

- Added “AEC-Q104 compliant” in section 2.
- Removed the description of note in section 5.2.8.
- Added the Proprietary commands of Set up the NMEA message output in section 5.2.9.

Revision 1.2 (February 29, 2024)

- Revised protocol support in section 4.

Revision 1.3 (March 4, 2024)

- Revised NMEA GGA, GLL and RMC message in section 5.1.