

Product name	Description	Version
MC-1010-Vxx	Dual-frequency multi-constellation GNSS positioning module	0.4



1 Introduction

LOCOSYS MC-1010-Vxx series are high-performance dual-band GNSS positioning modules that are capable of tracking all global civil navigation systems. They adopt 12 nm process and integrate efficient power management architecture to perform low power and high sensitivity. Besides, concurrent reception of L1 and L5 band signals mitigates the multipath delay and achieves sub-meter position accuracy.

The modules support hybrid ephemeris prediction to achieve faster cold start. One is self-generated ephemeris prediction (called EASY) that is no need of both network assistance and host CPU's intervention. This is valid for up to 3 days and updates automatically from time to time when GNSS module is powered on and satellites are available. The other is server-generated ephemeris prediction (called EPO) that gets from an internet server. This is valid for up to 14 days. Both ephemeris predictions are stored in the on-board flash memory and perform a cold start time less than 15 seconds.

The RF front end of MC-1010-V3x is specifically designed to comply with sensitivity specification contained in AIS 140 standard (please refer to note in the Fig 3-2). It is the best solution to those customers that design tracking applications in compliance with AIS 140.

2 Features

- Support GPS, GLONASS, GALILEO, BEIDOU, QZSS and NAVIC
- Capable of SBAS (WAAS, EGNOS, MSAS, GAGAN)
- Support 135-channel GNSS
- Ultra low power consumption
- Fast TTFF at low signal level
- Free hybrid ephemeris prediction to achieve faster cold start
- Up to 10 Hz update rate (TBR)
- ±15ns high accuracy time pulse (PPS)
- IATF 16949 quality control
- Small form factor 10.1 x 9.7 x 2.2 mm
- SMD type with stamp holes; RoHS compliant

3 Application

- Personal positioning and navigation

- Automotive navigation
- Autonomous Vehicle (ex: AVN/T-BOX/HUD)
- Marine navigation
- Fleet management
- Unmanned Aerial Vehicles
- Hand-Held Device
- Tracker

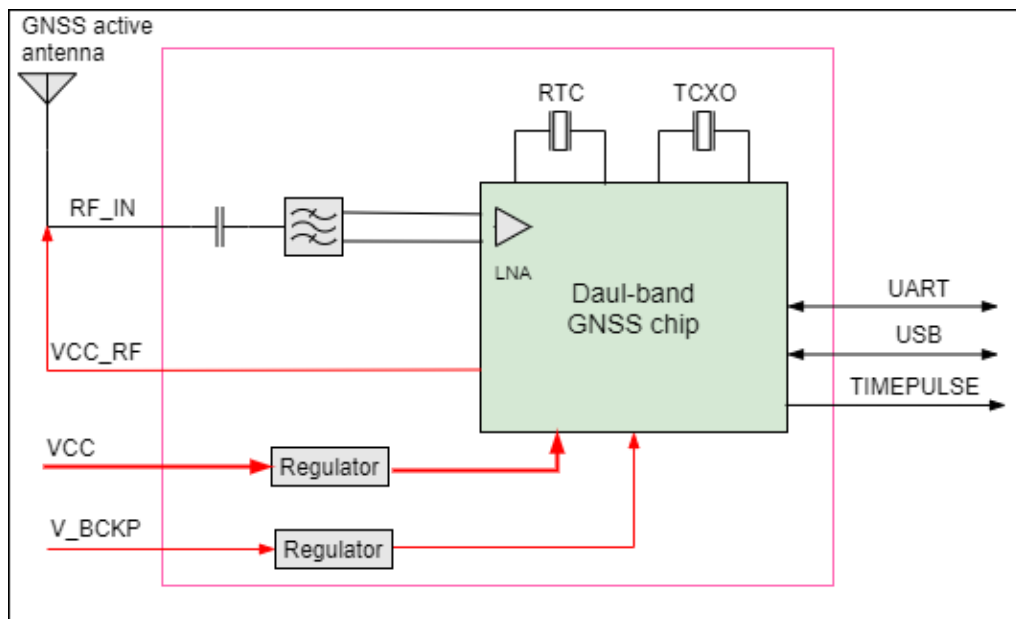

Fig 3-1 System block diagram.

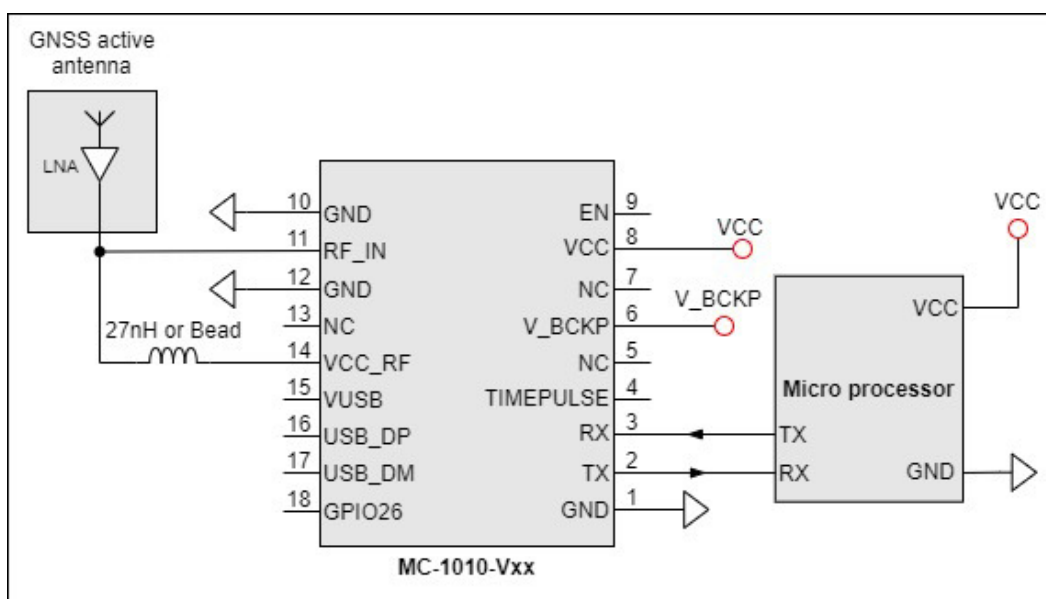

Fig 3-2 Typical application circuit that uses an active antenna.

Note: MC-1010-V3x with the active antenna can comply with the sensitivity specification contained in AIS 140 standard.

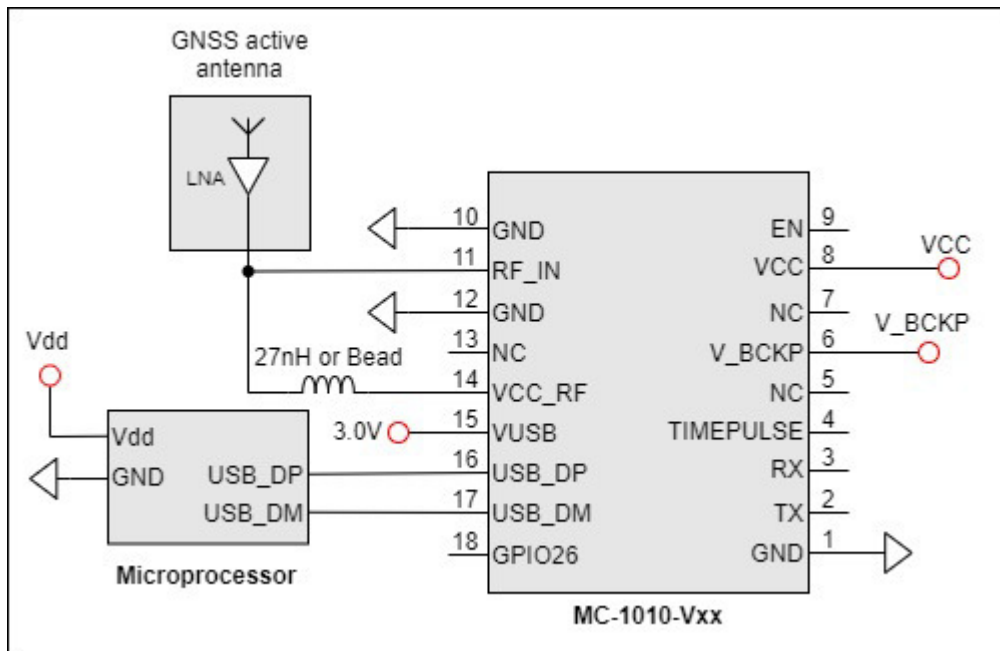

Fig 3-3 Typical application circuit that uses USB interface.

4 Product marking and ordering information

4.1 Product marking

The marking of the module is engraved on the metal shielding that has product information, such as LOCOSYS logo, product name and manufacturing date.

4.2 Ordering information

Product name	Input Voltage	Description	Remark
MC-1010-V2a	1.8V	Dual-frequency multi-constellation GNSS positioning module	GPS, GLONASS, GALILEO, BEIDOU, QZSS.
MC-1010-V2b	3.3V	Dual-frequency multi-constellation GNSS positioning module	GPS, GLONASS, GALILEO, BEIDOU, QZSS.
MC-1010-V3a	1.8V	Dual-frequency multi-constellation GNSS positioning module	GPS, GLONASS, GALILEO, BEIDOU, QZSS, IRNSS. For L5 band, only support IRNSS.
MC-1010-V3b	3.3V	Dual-frequency multi-constellation GNSS positioning module	GPS, GLONASS, GALILEO, BEIDOU, QZSS, IRNSS. For L5 band, only support IRNSS.

5 GNSS receiver

Frequency	MC-1010-V2a MC-1010-V2b	GPS/QZSS: L1 C/A, L5C GLONASS: L1OF GALILEO: E1, E5a BEIDOU: B1I, B2a
	MC-1010-V3a MC-1010-V3b	GPS/QZSS: L1 C/A GLONASS: L1OF GALILEO: E1 BEIDOU: B1I IRNSS (NAVIC): L5
Channels	Support 135 channels	
Update rate	1Hz default, up to 10Hz (TBR)	
Sensitivity	Tracking	-165dBm (with external LNA)
	Cold start	-148dBm (with external LNA)

Acquisition Time	Hot start (Open Sky)	1s (typical)
	Cold Start (Open Sky)	28s (typical) without AGPS
		< 15s (typical) with AGPS (ephemeris prediction)
Position Accuracy ⁽¹⁾	GNSS	< 1m CEP
Max. Altitude	< 18,000 m	
Max. Velocity	< 515 m/s	
Protocol Support	NMEA 0183 ver. 4.1	115200 bps ⁽²⁾ , 8 data bits, no parity, 1 stop bits (default)
		1Hz: GGA, GLL, GSA, GSV, RMC, VTG

Note 1: Open sky, dual band, demonstrated with a good external LNA.

Note 2: Both baud rate and output message rate are configurable to be factory default.

6 Software interface

6.1 NMEA output message

Table 6.1-1 NMEA output message

NMEA record	Description
GGA	Global positioning system fixed data
GLL	Geographic position - latitude/longitude
GSA	GNSS DOP and active satellites
GSV	GNSS satellites in view
RMC	Recommended minimum specific GNSS data
VTG	Course over ground and ground speed

● GGA--- Global Positioning System Fixed Data

Table 6.1-2 contains the values for the following example:

\$GNGGA,091250.000,2503.71250,N,12138.74514,E,1,32,0.55,119.0,M,17.2,M,,*7E

Table 6.1- 2 GGA Data Format

Name	Example	Units	Description
Message ID	\$GNGGA		GGA protocol header
UTC Time	091250.000		hhmmss.sss
Latitude	2503.71250		ddmm.mmmmm
N/S indicator	N		N=north or S=south
Longitude	12138.74514		dddmm.mmmmm
E/W Indicator	E		E=east or W=west
Position Fix Indicator	1		See Table 6.1-3
Satellites Used	32		Number of satellites in view
HDOP	0.55		Horizontal Dilution of Precision (meters)
MSL Altitude	119.0	meters	Antenna Altitude above/below mean-sea-level (geoid) (in meters)
Units	M	meters	Units of antenna altitude, meters
Geoidal Separation	17.2	meters	
Units	M	meters	Units of geoidal separation, meters
Age of diff. GNSS data		second	Null fields when DGPS is not used
Diff. Ref. Station ID			Differential reference station ID, 0000-1023
Checksum	*7E		Checksum
<CR> <LF>			End of message termination

Table 6.1-3 Position Fix Indicators

Value	Description
0	No position fix

1	Autonomous GNSS fix
2	Differential GNSS fix
4	RTK fixed
5	RTK float

● **GLL--- Geographic Position – Latitude/Longitude**

Table 6.1-4 contains the values for the following example:

\$GNGLL,2503.71193,N,12138.74582,E,094450.000,A,A*47

Table 6.1-4 GLL Data Format

Name	Example	Units	Description
Message ID	\$GNGLL		GLL protocol header
Latitude	2503.71193		ddmm.mmmmm
N/S indicator	N		N=north or S=south
Longitude	12138.74582		dddmm.mmmmm
E/W indicator	E		E=east or W=west
UTC Time	094450.000		hhmmss.sss
Status	A		A=data valid or V=data not valid
Mode	A		N = No position fix A = Autonomous GNSS fix D = Differential GNSS fix R = RTK fixed F = RTK float E = Estimated/Dead reckoning fix
Checksum	*47		
<CR> <LF>			End of message termination

● **GSA---GNSS DOP and Active Satellites**

Table 6.1-5 contains the values for the following example:

\$GNGSA,A,3,11,195,194,199,08,07,01,27,16,09,23,,1.19,0.64,1.00,1*3F

\$GNGSA,A,3,87,81,76,,,,,,,,,1.19,0.64,1.00,2*0F

\$GNGSA,A,3,,,,,,,,,1.19,0.64,1.00,3*09

\$GNGSA,A,3,34,24,12,07,11,10,08,38,25,09,13,16,1.19,0.64,1.00,4*02

Table 6.1-5 GSA Data Format

Name	Example	Units	Description
Message ID	\$GNGSA		GSA protocol header
Mode 1	A		See Table 6.1-6
Mode 2	3		See Table 6.1-7

ID of satellite used	11		SV on Channel 1
ID of satellite used	195		SV on Channel 2
....		
ID of satellite used			SV on Channel 12
PDOP	1.19		Position Dilution of Precision
HDOP	0.64		Horizontal Dilution of Precision
VDOP	1.00		Vertical Dilution of Precision
GNSS system ID	1		See Table 6.1-8
Checksum	*3F		
<CR> <LF>			End of message termination

Table 6.1-6 Mode 1

Value	Description
M	Manually set to operate in 2D or 3D mode
A	Automatically switching between 2D or 3D mode

Table 6.1-7 Mode 2

Value	Description
1	No position fix
2	2D fix
3	3D fix

Table 6.1-8 GNSS system ID

Value	Description
1	GPS
2	GLONASS
3	GALILEO
4	BEIDOU
6	IRNSS

● **GSV---GNSS Satellites in View**

Table 6.1-9 contains the values for the following example:

```
$GPGSV,3,1,09,8,71,268,47,27,63,18,49,11,44,191,46,4,41,237,46,1*54
$GPGSV,3,2,09,16,38,42,42,9,32,279,39,26,22,70,38,31,15,131,36,1*56
$GPGSV,3,3,09,7,15,320,40,1*6B
$GPGSV,1,1,04,8,71,268,50,27,63,18,49,9,32,279,43,26,22,70,42,8*6C
$GGLSV,2,1,05,82,63,47,47,83,56,182,36,80,47,9,42,79,33,85,45,1*71
$GGLSV,2,2,05,81,15,27,37,1*71
$GAGSV,1,1,04,08,48,300,43,03,47,025,45,13,36,309,42,05,06,061,34,7*79
$GAGSV,1,1,04,08,48,300,43,03,47,025,47,13,36,309,43,05,06,061,33,1*7B
```

\$GBGSV,5,1,17,12,80,182,47,24,64,5,51,7,58,355,44,3,57,205,45,1*7C
 \$GBGSV,5,2,17,1,54,141,44,34,52,211,49,9,48,230,45,10,47,316,42,1*79
 \$GBGSV,5,3,17,26,44,100,47,16,39,207,43,4,38,117,41,2,37,240,41,1*77
 \$GBGSV,5,4,17,39,37,210,43,6,36,198,41,38,27,173,41,25,18,317,42,1*4E
 \$GBGSV,5,5,17,35,16,39,40,1*7F
 \$GBGSV,1,1,02,24,64,5,50,26,44,100,43,4*77

Table 6.1-9 GSV Data Format

Name	Example	Units	Description
Message ID	\$GPGSV		GSV protocol header GP=GPS/QZSS, GL=GLONSS, GA=GALILEO, GB=BEIDOU, GI=IRNSS.
Total number of messages	3		Range 1 to 9
Message number	1		Range 1 to 9
Satellites in view	09		
Satellite ID	8		Channel 1
Elevation	71	degrees	Channel 1 (Range 00 to 90)
Azimuth	268	degrees	Channel 1 (Range 000 to 359)
SNR (C/No)	47	dB-Hz	Channel 1 (Range 00 to 99, null when not tracking)
....		
Satellite ID	4		Channel 4 (Range 01 to 196)
Elevation	41	degrees	Channel 4 (Range 00 to 90)
Azimuth	237	degrees	Channel 4 (Range 000 to 359)
SNR (C/No)	46	dB-Hz	Channel 4 (Range 00 to 99, null when not tracking)
Signal ID	1		GPS/QZSS: L1 C/A=1, L5Q=8 GLONASS: L1 C/A=1 GALILEO: E1=7, E5a=1 BEIDOU: B1=1, B2a=4 IRNSS: L6=1
Checksum	*54		
<CR> <LF>			End of message termination

● **RMC---Recommended Minimum Specific GNSS Data**

Table 6.1-10 contains the values for the following example:

\$GNRMC,070143.000,A,2503.71317,N,12138.74533,E,0.002,70.50,130220,,,A,V*01

Table 6.1-10 RMC Data Format

Name	Example	Units	Description
Message ID	\$GNRMC		RMC protocol header

UTC Time	070143.000		hhmmss.sss
Status	A		A=data valid or V=data not valid
Latitude	2503.71317		ddmm.mmmmm
N/S Indicator	N		N=north or S=south
Longitude	12138.74533		dddmm.mmmmm
E/W Indicator	E		E=east or W=west
Speed over ground	0.002	knots	True
Course over ground	70.50	degrees	
Date	130220		ddmmyy
Magnetic variation		degrees	
Variation sense			E=east or W=west
Mode	A		N = No position fix A = Autonomous GNSS fix D = Differential GNSS fix R = RTK fixed F = RTK float E = Estimated/Dead reckoning fix
Navigational status indicator	V		S = Safe C = Caution U = Unsafe V = Void
Checksum	*01		
<CR> <LF>			End of message termination

● **VTG---Course Over Ground and Ground Speed**

Table 6.1-11 contains the values for the following example:

\$GNVTG,0.00,T,,M,0.003,N,0.006,K,A*26

Table 6.1-11 VTG Data Format

Name	Example	Units	Description
Message ID	\$GNVTG		VTG protocol header
Course over ground	0.00	degrees	Measured heading
Reference	T		True
Course over ground		degrees	Measured heading
Reference	M		Magnetic
Speed over ground	0.003	knots	Measured speed
Units	N		Knots
Speed over ground	0.006	km/hr	Measured speed

Units	K		Kilometer per hour
Mode	A		N = No position fix A = Autonomous GNSS fix D = Differential GNSS fix R = RTK fixed F = RTK float E = Estimated/Dead reckoning fix
Checksum	*26		
<CR> <LF>			End of message termination

6.2 Proprietary command sets

The following table shows the most common use proprietary command sets.

Table 6.2-1 The table below summarizes the set of proprietary command sets for the MC-1010-Vxx

Command descriptions	Software command
Perform HOT_START	\$PAIR004*3E\r\n
Perform WARM_START	\$PAIR005*3F\r\n
Perform COLD_START	\$PAIR006*3C\r\n
Perform FULL_COLD_START	\$PAIR007*3D\r\n
Set OUTPUT BAUDRATE [Note] Must reboot the device after changing the port baud rate. The change will valid after reboot.	\$PAIR864,0,0,115200*1B\r\n \$PAIR864,0,0,230400*19\r\n \$PAIR864,0,0,460800*16\r\n \$PAIR864,0,0,921600*10\r\n \$PAIR864,0,0,3000000*2F\r\n
Set SPEED THRESHOLD [NOTE] Speed_threshold. 0~20 dm/s. Default value is 0 dm/s. The minimum is 1 dm/s, the maximum is 20 dm/s. 1 dm/s = 0.1m/s	\$PAIR070,15*15\r\n --- 1.5m/s
Query SPEED _THRESHOLD	Send: \$PAIR071*3C\r\n Response: \$PAIR001,071,0*3D\r\n ==> Success \$PAIR071,1.5*3A\r\n
Set DGPS MODE [NOTE] Mode: DGPS data source mode. '0': No DGPS source	\$PAIR400,0*22\r\n ==> Set No DGPS source \$PAIR400,1*23\r\n ==> Set RTCM \$PAIR400,2*20\r\n ==> Set SBAS Mode

'1': RTCM '2': SBAS(Include WAAS/EGNOS/GAGAN/ MSAS)	
Query DGPS MODE [NOTE] Mode: DGPS data source mode. '0': No DGPS source '1': RTCM '2': SBAS(Include WAAS/EGNOS/GAGAN/ MSAS)	Send: \$PAIR401*3F\r\n Response: \$PAIR001,401,0*3E\r\n ==> Success \$PAIR401,2*21\r\n ==> SBAS Mode
Enable or Disable SBAS SATELLITE SEARCHING	\$PAIR410,0*23\r\n ==> Disable SBAS \$PAIR410,1*22\r\n ==> Enable SBAS

7 Pin assignment and descriptions



Table 7-1 Pin descriptions

Pin #	Name	Type	Description	Note
1	GND	P	Ground	
2	TX	O	Serial output	
3	RX	I	Serial input	
4	TIMEPULSE	O	Time pulse (PPS, default 100 ms pulse/sec when GNSS fix is available)	
5	NC		Not connect	
6	V_BCKP	P	Backup battery input. It is recommended to connect a backup supply voltage to V_BCKP in order to enable warm and hot start features. Moreover, V_BCKP is a must of the system running. If no backup power is available, connect V_BCKP to the main power supply (VCC).	1
7	NC		Not connect	
8	VCC	P	DC supply input. Must be clean and stable.	
9	EN	I	Enable the module, high active. Internal 1M ohm pull-up resistor to 1.8V. Leave unconnected if not used.	
10	GND	P	Ground	
11	RF_IN	I	GNSS RF signal input	
12	GND	P	Ground	

13	NC		Not connect	
14	VCC_RF	O	Output voltage for active antenna	
15	VUSB	I	USB voltage supply. Connect this pin to 2.92 ~ 3.22V to enable USB interface. Leave unconnected if not used.	
16	USB_DP	I/O	USB D+ line. Leave unconnected if not used.	
17	USB_DM	I/O	USB D- line. Leave unconnected if not used.	
18	GPIO26	I/O	General purpose I/O	

Note 1: In order to get the advantage of hybrid ephemeris prediction, this pin must be always powered during the period of effective ephemeris prediction.

8 DC & Temperature characteristics

8.1 Absolute maximum ratings

Parameter	Symbol	Model	Ratings	Units
DC Supply Input Voltage	VCCabs	MC-1010-V2a	5.5	V
		MC-1010-V2b	1.98	
Input Backup Battery Voltage	V_BCKPabs	MC-1010-V2a	5.5	V
		MC-1010-V2b	1.98	
Operating Temperature Range	Topr_abs	All	-40 ~ 85	°C
Storage Temperature Range	Tstg_abs	All	-40 ~ 85	°C

8.2 DC Electrical characteristics

8.2.1 For 1.8V operating voltage: MC-1010-V2a and MC-1010-V3a

Parameter	Symbol	Conditions	Min.	Typ.	Max.	Units
DC Supply Input Voltage	VCC		1.73	1.8	1.98	V
Input Backup Battery Voltage	V_BCKP		1.62		1.98	V
VCC_RF Output Voltage	VCC_RF			VCC		V
Supply Current	Iss	VCC = 1.8V, w/o active antenna, Peak Acquisition Tracking			TBD ⁽¹⁾	mA
				30		mA
				40 ⁽²⁾		mA
Backup Battery Current	Ibat	VIN = 0V		44		uA
VCC_RF Output Current	Iout	VIN = 1.8V			TBD	mA
High Level Input Voltage	V _{IH}		0.65*VCC		VCC	V
Low Level Input Voltage	V _{IL}		-0.3		0.35*VCC	V
High Level Output Voltage	V _{OH}		VCC-0.45		VCC	V

Low Level Output Voltage	V_{OL}				0.45	V
--------------------------	----------	--	--	--	------	---

Note 1: This happens when downloading AGPS data to the module.

Note 2: Measured when position fix (1Hz) is available, input voltage is 1.8V and the function of self-generated ephemeris prediction is inactive.

8.2.2 For 3.3V operating voltage: MC-1010-V2b and MC-1010-V3b

Parameter	Symbol	Conditions	Min.	Typ.	Max.	Units
DC Supply Input Voltage	VCC		3.1	3.3	4.5	V
Input Backup Battery Voltage	V_BCKP		2.0		4.5	V
VCC_RF Output Voltage	VCC_RF		2.9	3	3.1	V
Supply Current	I_{ss}	VCC = 3.3V, w/o active antenna, Peak			110 ⁽¹⁾	mA
		Acquisition(UART)		37.57		mA
		Acquisition(USB)		46.81		mA
		Tracking(UART)		55.27 ⁽²⁾		mA
		Tracking(USB)		63.65 ⁽²⁾		mA
Backup Battery Current	I_{bat}	VIN = 0V		44		uA
VCC_RF Output Current	I_{out}	VIN = 3.3V			30	mA
High Level Input Voltage	V_{IH}		2.2		3.6	V
Low Level Input Voltage	V_{IL}		-0.3		0.8	V
High Level Output Voltage	V_{OH}		2.18		3.3	V
Low Level Output Voltage	V_{OL}				0.4	V

Note 1: This happens when downloading AGPS data to the module.

Note 2: Measured when position fix (1Hz) is available, input voltage is 3.3V and the function of self-generated ephemeris prediction is inactive.

8.3 Temperature characteristics

Parameter	Symbol	Min.	Typ.	Max.	Units
Operating Temperature	T_{opr}	-40	-	85	°C
Storage Temperature	T_{stg}	-40	25	85	°C

9 Mechanical specification

9.1 Outline dimensions

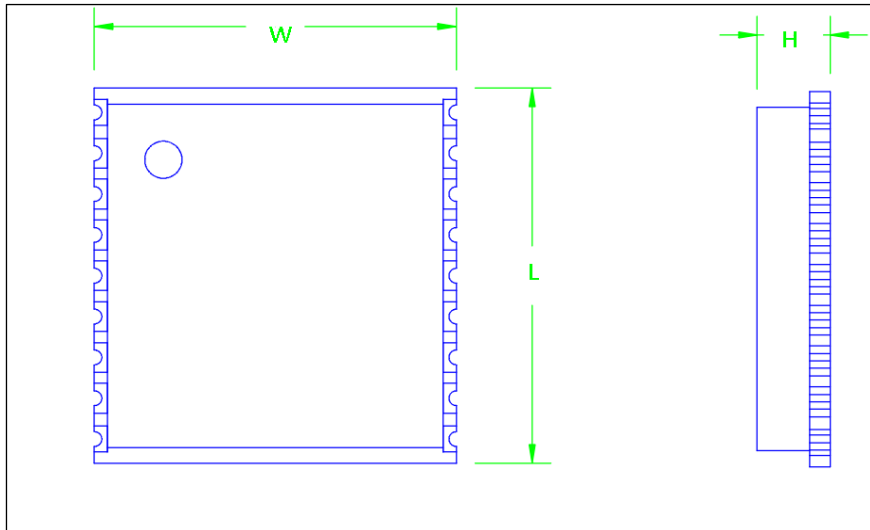

Symbol	Min. (mm)	Typ. (mm)	Max. (mm)
W	9.6	9.7	9.8
L	9.8	10.1	10.4
H	2.0	2.2	2.4

9.2 Recommended land pattern dimensions

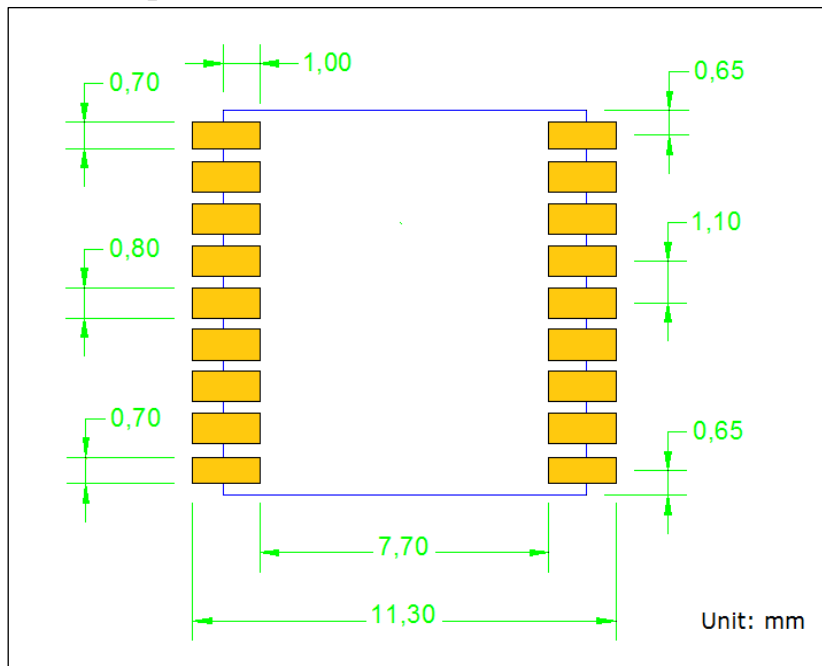

Note: The recommended land pattern dimensions are shown for reference only, as actual pad layouts may vary depending on application.

10 Reel Packing information

10.1 ESD precaution

GNSS modules are electrostatic sensitive devices. Handling the modules without proper ESD protection may result in severe damage to them. ESD protection must be implemented throughout the processing, handling and even when the modules are being returned for repair.

10.2 Packaging

The modules are sealed in a moisture barrier ESD bag with the appropriate units of desiccant and a humidity indicator card. It should not be opened until the modules are ready to be soldered onto the application.

10.2.1 Packaging

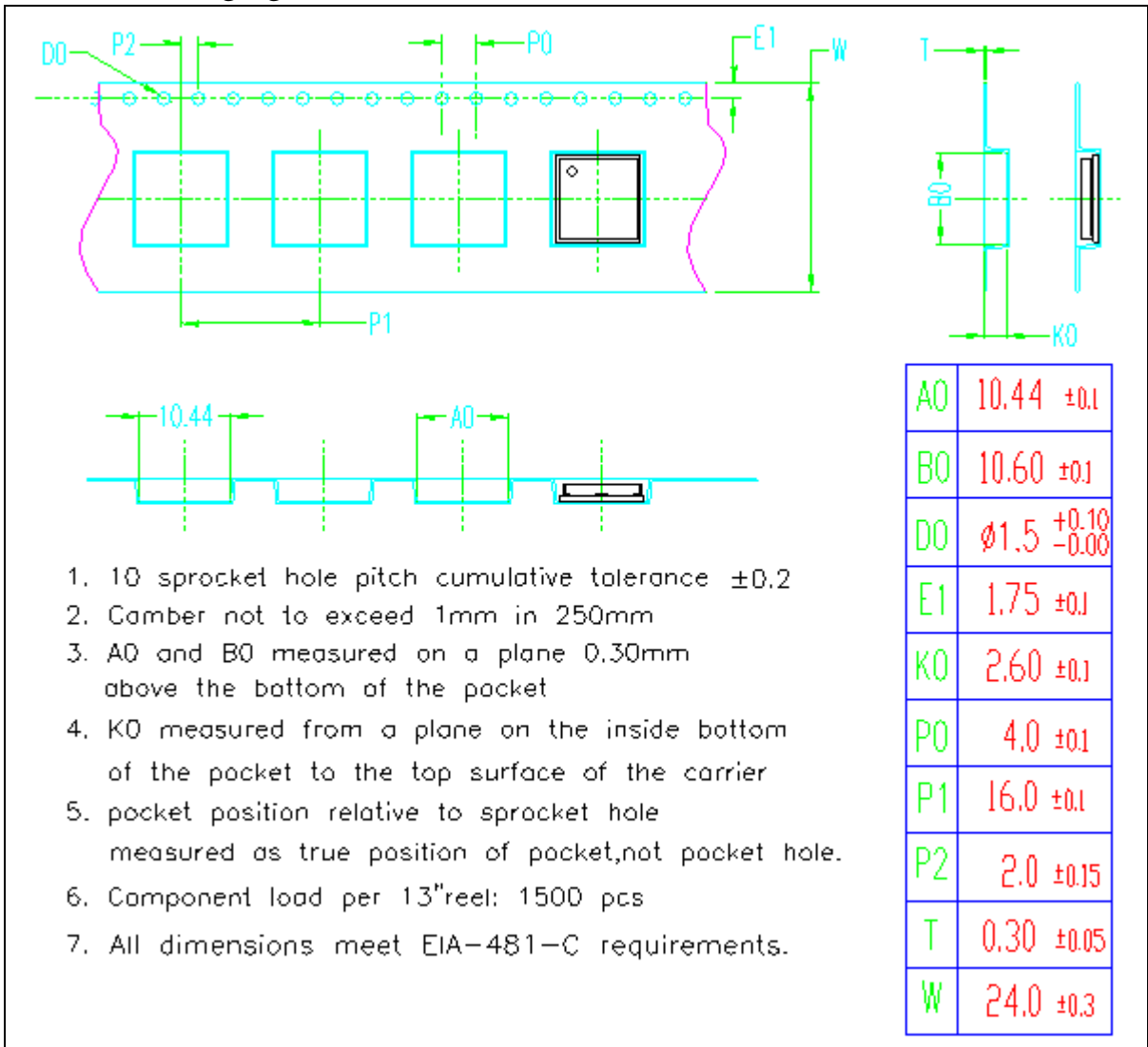

10.2.2 Box packaging

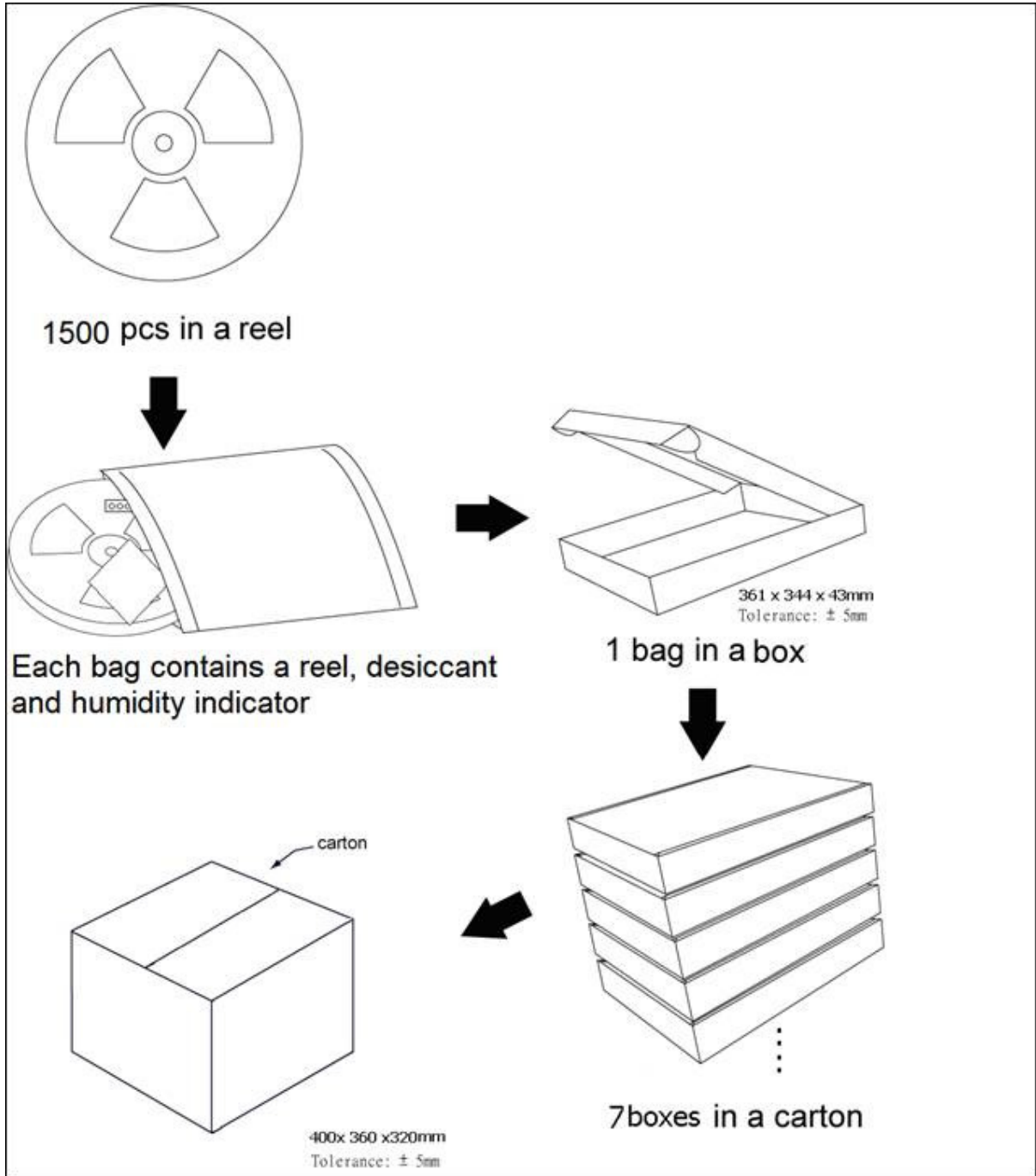

10.3 Moisture sensitivity level

The moisture sensitivity level of the module is 3. After the sealed bag is opened, modules should be mounted within 168 hours at factory conditions of $\leq 30^{\circ}\text{C}$ and 60% RH or stored at $\leq 20\%$ RH.

The modules require baking before mounting if above conditions are not met. If baking is required, the modules without the tape and reel may be baked for:

- a. 192 hours at $40^{\circ}\text{C} + 5^{\circ}\text{C} / -0^{\circ}\text{C}$ and $< 5\%$ RH
- b. 24 hours at $125^{\circ}\text{C} + 5^{\circ}\text{C} / -0^{\circ}\text{C}$

10.4 Reflow soldering

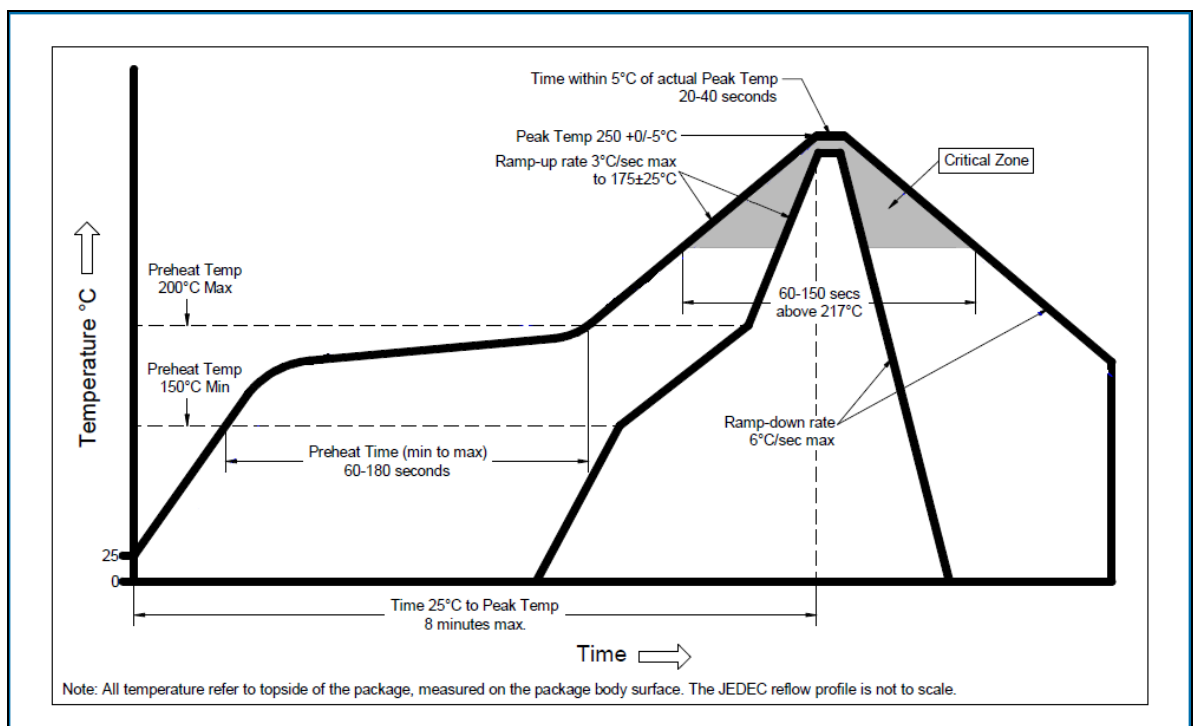

Note the module mounted to the top side (first reflow side) may fall off during reflow soldering of the bottom side.

Document change list

Revision 0.1

- Draft release on July 15, 2020.

Revision 0.2 (August 24, 2020)

- Added the compliant description of AIS 140 in section 1.
- Added the Note in the Fig 3-2.

Revision 0.3 (September 24, 2020)

- Added the proprietary command sets in section 6.2.

Revision 0.4 (October 21, 2020)

- Revised the description of up to 10 Hz update rate in section 2.
- Revised the description of update rate in section 5.
- Revised GSV message in section 6.1.
- Changed peak current from TBD to 110 mA in section 8.2.2.
- Changed acquisition current from 30 mA to 37.57 mA in section 8.2.2.
- Changed tracking current from 40 mA to 55.27 mA in section 8.2.2.
- Added acquisition / tracking current of USB in section 8.2.2.