

Product name	Description	Version
MC-1010-G	Standalone multiple GNSS module	1.2



1 Introduction

LOCOSYS MC-1010-G is a complete standalone GNSS module. The module can simultaneously acquire and track multiple satellite constellations that include GPS, GLONASS, GALILEO, QZSS and SBAS. It features low power and small form factor. Besides, it can provide you with superior sensitivity and performance even in urban canyon and dense foliage environment.

This module supports hybrid ephemeris prediction to achieve faster cold start. One is self-generated ephemeris prediction (called EASY) that is no need of both network assistance and host CPU's intervention. This is valid for up to 3 days and updates automatically from time to time when GNSS module is powered on and satellites are available. The other is server-generated ephemeris prediction (called EPO) that gets from an internet server. This is valid for up to 14 days. Both ephemeris predictions are stored in the on-board flash memory and perform a cold start time less than 15 seconds.

2 Features

- MediaTek high sensitivity solution
- Support GPS, GLONASS, GALILEO and QZSS
- Capable of SBAS (WAAS, EGNOS, MSAS, GAGAN)
- Support 99-channel GNSS
- Ultra low power consumption
- Fast TTFF at low signal level
- Built-in 12 multi-tone active interference canceller
- Free hybrid ephemeris prediction to achieve faster cold start
- Built-in data logger
- Built-in DC/DC converter to save power
- Allow direct connection with the lithium battery
- Built-in off-chip LNA to get best performance when using passive antenna
- Up to 10 Hz update rate
- ± 1 ns high accuracy time pulse (1PPS)
- Indoor and outdoor multi-path detection and compensation
- Small form factor 10.1 x 9.7 x 2 mm
- SMD type with stamp holes; RoHS compliant

3 Application

- Personal positioning and navigation
- Automotive navigation
- Marine navigation

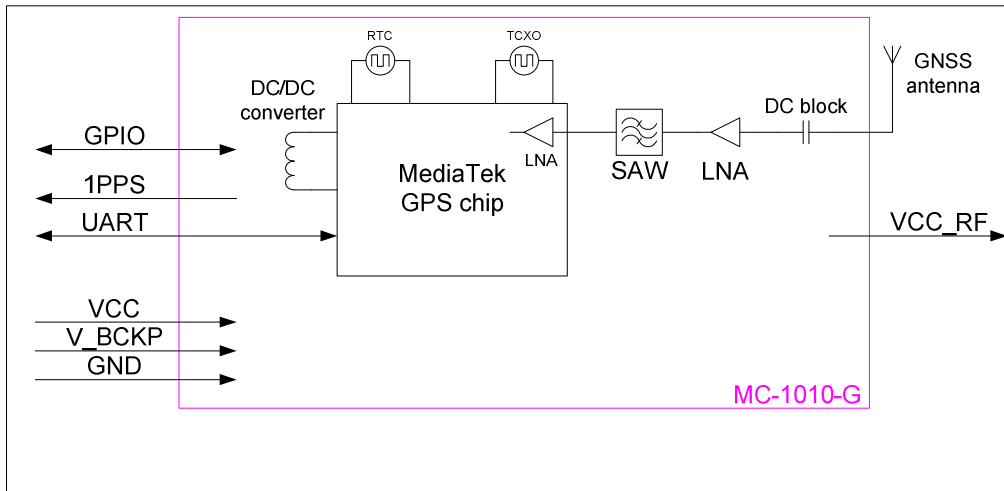

Fig 3-1 System block diagram.

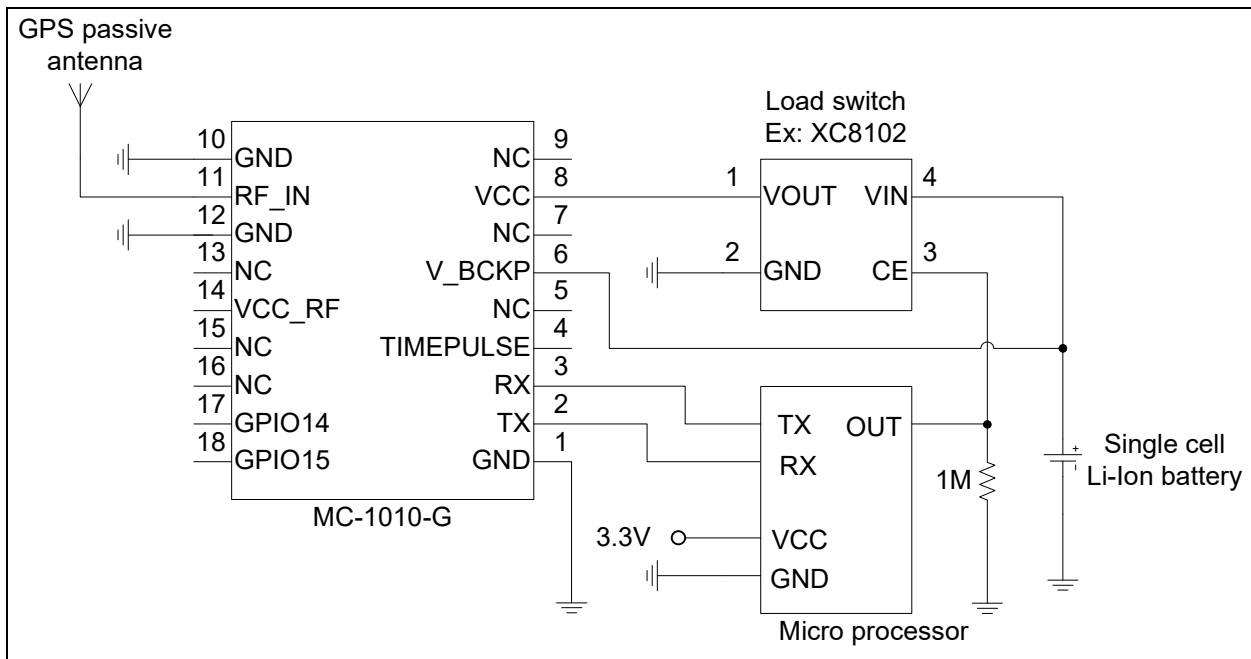

Fig 3-2 Directly use a passive antenna and a Li-Ion battery to save power.

Note: When using an active antenna with MC-1010-G, the overall gain of the active antenna must be smaller than 18dB.

4 GNSS receiver

Chip	MediaTek MT3333	
Frequency	GPS, GALILEO ⁽¹⁾ , QZSS: L1 1575.42MHz, C/A code GLONASS: L1 1598.0625MHz ~ 1605.375MHz, C/A code	
Channels	Support 99 channels (33 Tracking, 99 Acquisition)	
Update rate	1Hz default, up to 10Hz	
Sensitivity	Tracking	-164dBm, up to -165dBm
	Cold start	-147dBm, up to -148dBm
Acquisition Time	Hot start (Open Sky)	1s (typical)
	Hot start (Indoor)	< 30s (typical)
	Cold Start (Open Sky)	33s (typical) without AGPS
< 15s (typical) with AGPS (hybrid ephemeris prediction)		
Position Accuracy	Autonomous	2.5m CEP
	SBAS	2.5m (depends on accuracy of correction data).
Max. Altitude	< 18,000 m, up to 50,000m by request	
Max. Velocity	< 515 m/s	
Protocol Support	NMEA 0183 ver 4.00	9600 bps ⁽²⁾ , 8 data bits, no parity, 1 stop bits (default)
		1Hz: GGA, GLL, GSA, GSV, RMC, VTG

Note 1: MC-1010-G module is default configured for concurrent GPS, GLONASS, QZSS and SBAS reception.

Please contact us for different default configuration, such as concurrent GPS, GLONASS, GALILEO, QZSS and SBAS.

Note 2: Both baud rate and output message rate are configurable to be factory default.

5 Software interface

5.1 NMEA output message

Table 5.1-1 NMEA output message

NMEA record	Description
GGA	Global positioning system fixed data
GLL	Geographic position - latitude/longitude
GSA	GNSS DOP and active satellites
GSV	GNSS satellites in view
RMC	Recommended minimum specific GNSS data
VTG	Course over ground and ground speed

- **GGA--- Global Positioning System Fixed Data**

Table 5.1-2 contains the values for the following example:

\$GPGGA,183015.000,2503.7123,N,12138.7446,E,2,16,0.68,123.2,M,15.3,M,0000,0000*66

Table 5.1- 2 GGA Data Format

Name	Example	Units	Description
Message ID	\$GPGGA		GGA protocol header
UTC Time	183015.000		hhmmss.sss
Latitude	2503.7123		ddmm.mmmm
N/S indicator	N		N=north or S=south
Longitude	12138.7446		dddmm.mmmm
E/W Indicator	E		E=east or W=west
Position Fix Indicator	2		See Table 5.1-3
Satellites Used	16		Range 0 to 33
HDOP	0.68		Horizontal Dilution of Precision
MSL Altitude	123.2	meters	
Units	M	meters	
Geoid Separation	15.3	meters	
Units	M	meters	
Age of Diff. Corr.	0000	second	Null fields when DGPS is not used
Diff. Ref. Station ID	0000		
Checksum	*66		
<CR> <LF>			End of message termination

Table 5.1-3 Position Fix Indicators

Value	Description
0	Fix not available or invalid
1	GPS SPS Mode, fix valid
2	Differential GPS, SPS Mode, fix valid
3-5	Not supported
6	Dead Reckoning Mode, fix valid

● GLL--- Geographic Position – Latitude/Longitude

Table 5.1-4 contains the values for the following example:

\$GPGLL,2503.7123,N,12138.7446,E,183015.000,A,D*59

Table 5.1-4 GLL Data Format

Name	Example	Units	Description
Message ID	\$GPGLL		GLL protocol header (GNGLL or GPGLL)
Latitude	2503.7123		ddmm.mmmm
N/S indicator	N		N=north or S=south
Longitude	12138.7446		dddmm.mmmm

E/W indicator	E		E=east or W=west
UTC Time	183015.000		hhmmss.sss
Status	A		A=data valid or V=data not valid
Mode	D		A=autonomous, D=DGPS, E=DR, N=Data not valid, R=Coarse Position, S=Simulator
Checksum	*59		
<CR> <LF>			End of message termination

● GSA---GNSS DOP and Active Satellites

Table 5.1-5 contains the values for the following example:

\$GNGSA,A,3,18,193,21,09,12,22,27,15,25,14,,,1.44,0.68,1.27*2F

\$GNGSA,A,3,76,72,77,75,66,65,,,,,1.44,0.68,1.27*12

Table 5.1-5 GSA Data Format

Name	Example	Units	Description
Message ID	\$GNGSA		GSA protocol header (GNGSA or GPGSA)
Mode 1	A		See Table 5.1-6
Mode 2	3		See Table 5.1-7
ID of satellite used	18		Sv on Channel 1
ID of satellite used	193		Sv on Channel 2
....		
ID of satellite used			Sv on Channel 12
PDOP	1.44		Position Dilution of Precision
HDOP	0.68		Horizontal Dilution of Precision
VDOP	1.27		Vertical Dilution of Precision
Checksum	*2F		
<CR> <LF>			End of message termination

Table 5.1-6 Mode 1

Value	Description
M	Manual- forced to operate in 2D or 3D mode
A	Automatic-allowed to automatically switch 2D/3D

Table 5.1-7 Mode 2

Value	Description
1	Fix not available
2	2D
3	3D

● GSV---GNSS Satellites in View

Table 5.1-8 contains the values for the following example:

```
$GPGSV,3,1,11,18,67,344,48,09,55,031,50,42,54,142,40,193,47,174,45*4D
$GPGSV,3,2,11,21,44,219,46,27,39,035,48,12,34,131,44,15,30,057,46*76
$GPGSV,3,3,11,22,27,319,47,14,22,285,42,25,19,171,40*44
$GLGSV,2,1,07,76,71,201,44,65,57,041,40,75,48,028,39,72,27,108,39*68
$GLGSV,2,2,07,66,25,333,43,77,17,207,37,81,02,280,29*5C
```

Table 5.1-8 GSV Data Format

Name	Example	Units	Description
Message ID	\$GPGSV		GSV protocol header (GPGSV and GLGSV)
Total number of messages ¹	3		Range 1 to 6
Message number ¹	1		Range 1 to 6
Satellites in view	11		
Satellite ID	18		Channel 1 (Range 01 to 196)
Elevation	67	degrees	Channel 1 (Range 00 to 90)
Azimuth	344	degrees	Channel 1 (Range 000 to 359)
SNR (C/No)	48	dB-Hz	Channel 1 (Range 00 to 99, null when not tracking)
Satellite ID	09		Channel 4 (Range 01 to 196)
Elevation	55	degrees	Channel 4 (Range 00 to 90)
Azimuth	031	degrees	Channel 4 (Range 000 to 359)
SNR (C/No)	50	dB-Hz	Channel 4 (Range 00 to 99, null when not tracking)
Checksum	*4D		
<CR> <LF>			End of message termination

1. Depending on the number of satellites tracked multiple messages of GSV data may be required.

● RMC---Recommended Minimum Specific GNSS Data

Table 5.1-9 contains the values for the following example:

```
$GNRMC,183015.000,A,2503.7123,N,12138.7446,E,0.01,34.92,270812,,D*43
```

Table 5.1-9 RMC Data Format

Name	Example	Units	Description
Message ID	\$GNRMC		RMC protocol header (GNRMC or GPRMC)
UTC Time	183015.000		hhmmss.sss
Status	A		A=data valid or V=data not valid
Latitude	2503.7123		ddmm.mmmm
N/S Indicator	N		N=north or S=south
Longitude	12138.7446		dddmm.mmmm
E/W Indicator	E		E=east or W=west
Speed over ground	0.01	knots	True

Course over ground	34.92	degrees	
Date	270812		ddmmyy
Magnetic variation		degrees	
Variation sense			E=east or W=west (Not shown)
Mode	D		A=autonomous, D=DGPS, E=DR, N=Data not valid, R=Coarse Position, S=Simulator
Checksum	*43		
<CR> <LF>			End of message termination

● VTG---Course Over Ground and Ground Speed

Table 5.1-10 contains the values for the following example:

\$GPVTG,34.92,T,,M,0.01,N,0.02,K,D*07

Table 5.1-10 VTG Data Format

Name	Example	Units	Description
Message ID	\$GPVTG		VTG protocol header
Course over ground	34.92	degrees	Measured heading
Reference	T		True
Course over ground		degrees	Measured heading
Reference	M		Magnetic
Speed over ground	0.01	knots	Measured speed
Units	N		Knots
Speed over ground	0.02	km/hr	Measured speed
Units	K		Kilometer per hour
Mode	D		A=autonomous, D=DGPS, E=DR, N=Data not valid, R=Coarse Position, S=Simulator
Checksum	*07		
<CR> <LF>			End of message termination

5.2 Proprietary NMEA input/output message

Please refer to MTK proprietary message.

5.3 Examples to configure the power mode of GNSS module

The GNSS module supports different power modes that user can configure by issuing software commands.

5.3.1 Standby mode

User can issue software command to make GNSS module go into standby mode that consumes less than 500uA current. GNSS module will be awaked when receiving any byte.

The following flow chart is an example to make GNSS module go into standby mode and then wake up.

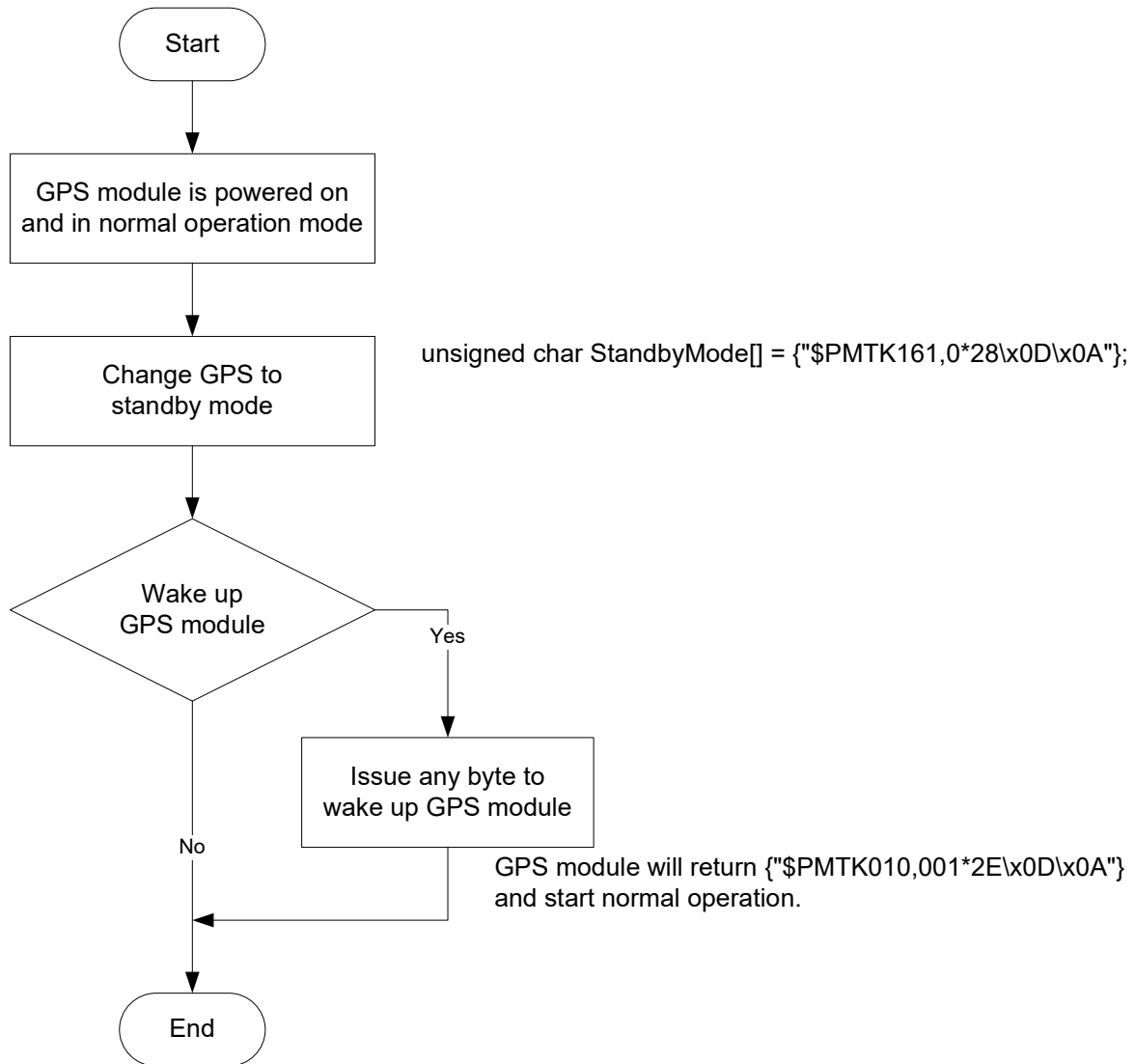

5.3.2 Periodic mode

When GNSS module is commanded to periodic mode, it will be in operation and standby periodically. Its status of power consumption is as below chart.

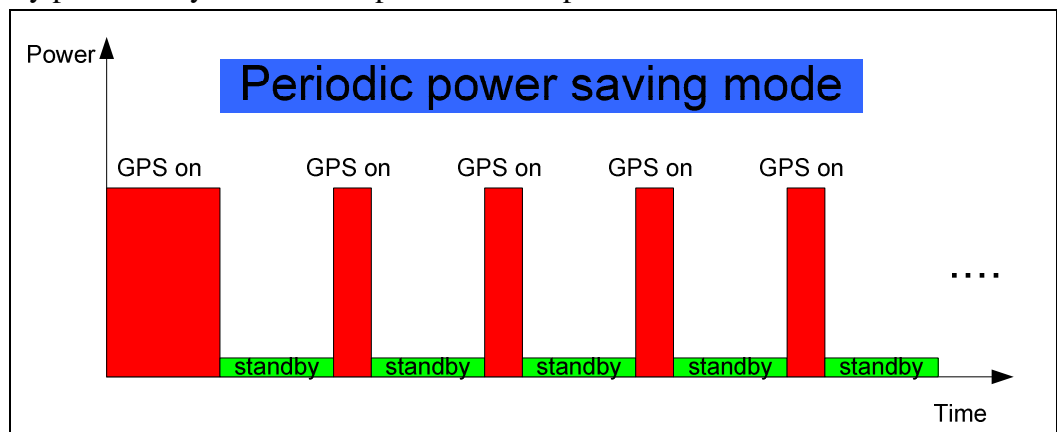

The following flow chart is an example to make GNSS module go into periodic mode and then back to normal operation mode.

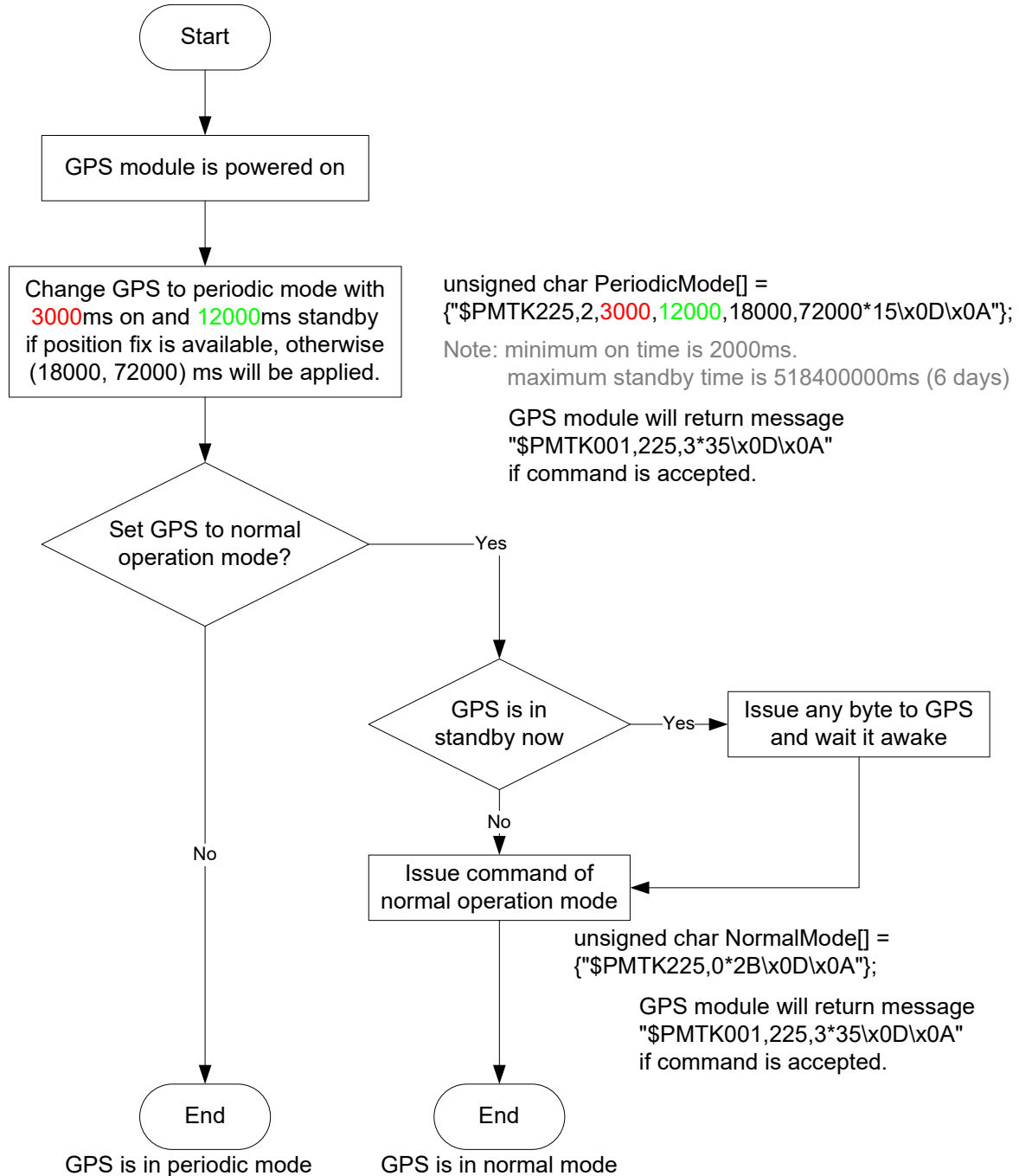

5.3.3 AlwaysLocate™ mode

AlwaysLocate™ is an intelligent controller of periodic mode. Depending on the environment and motion conditions, GNSS module can adaptively adjust working/standby time to achieve balance of positioning accuracy and power consumption. In this mode, the host CPU does not need to control GNSS module until the host CPU needs the GNSS

position data. The following flow chart is an example to make GNSS module go into AlwaysLocate™ mode and then back to normal operation mode.

Note: AlwaysLocate™ is a trade mark of MTK.

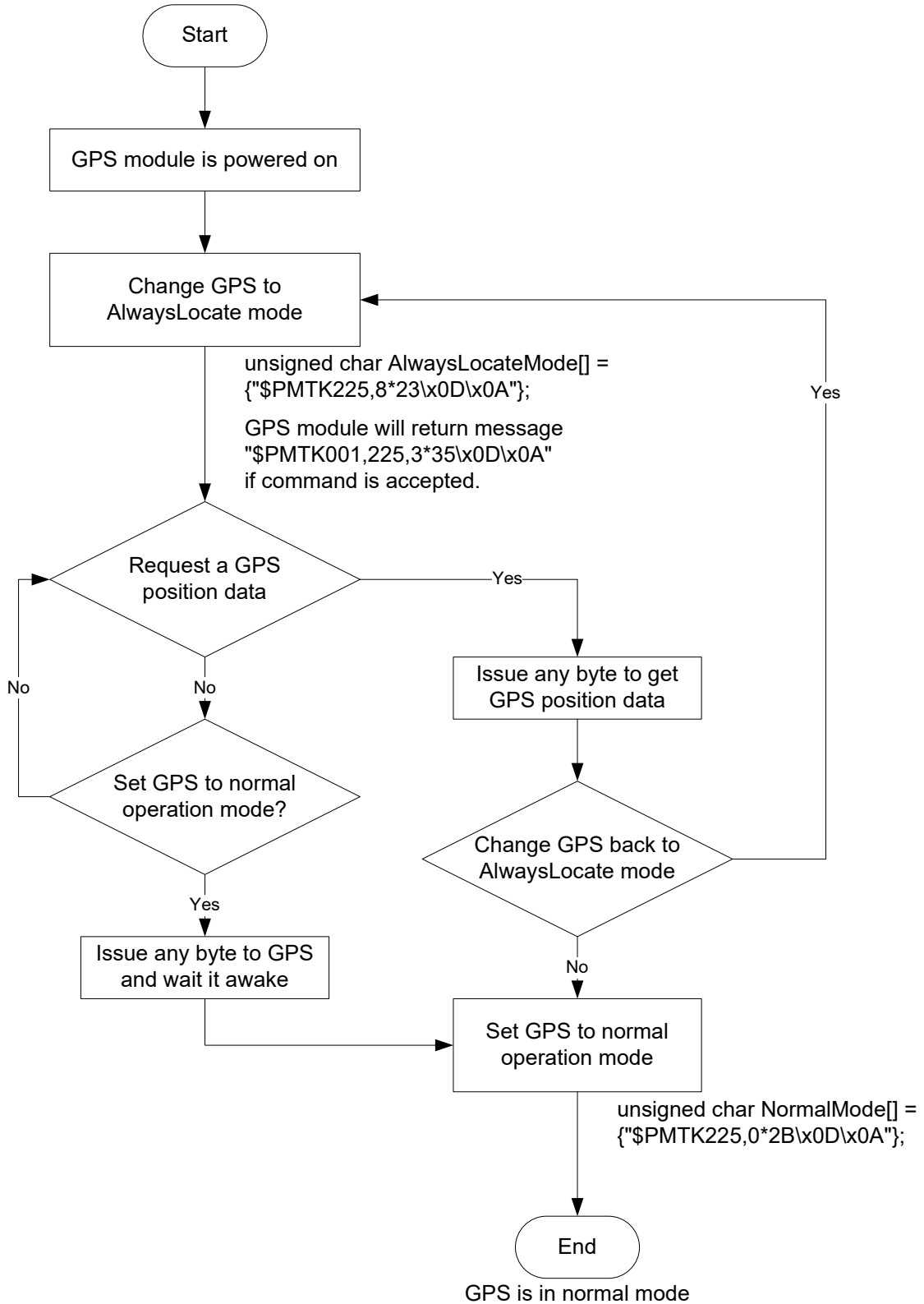

5.4 Data logger

The GNSS module has internal flash memory for logging GNSS data. The configurations include time interval, distance, speed, logging mode, and ... etc. For more information, please contact us.

5.5 Examples to configure the update rate of GNSS module

The GNSS module supports up to 10Hz update rate that user can configure by issuing software commands. Note that the configurations by software commands are stored in the battery-backed SRAM that is powered through VBACKUP pin. Once it drains out, the default/factory settings will be applied.

Due to the transmitting capacity per second of the current baud rate, GNSS module has to be changed to higher baud rate for high update rate of position fix. The user can use the following software commands to change baud rate.

Baud rate	Software command
Factory default	\$PMTK251,0*28<CR><LF>
4800	\$PMTK251,4800*14<CR><LF>
9600	\$PMTK251,9600*17<CR><LF>
19200	\$PMTK251,19200*22<CR><LF>
38400	\$PMTK251,38400*27<CR><LF>
57600	\$PMTK251,57600*2C<CR><LF>
115200	\$PMTK251,115200*1F<CR><LF>

Note: <CR> means Carriage Return, i.e. 0x0D in hexadecimal. <LF> means Line Feed, i.e. 0x0A in hexadecimal.

If the user does not want to change baud rate, you can reduce the output NMEA sentences by the following software commands.

NMEA sentence	Software command
Factory default	\$PMTK314,-1*04<CR><LF>
Only GLL at 1Hz	\$PMTK314,1,0,0,0,0,0,0,0,0,0,0,0,0,0,0,0*29<CR><LF>
Only RMC at 1Hz	\$PMTK314,0,1,0,0,0,0,0,0,0,0,0,0,0,0,0,0*29<CR><LF>
Only VTG at 1Hz	\$PMTK314,0,0,1,0,0,0,0,0,0,0,0,0,0,0,0,0*29<CR><LF>
Only GGA at 1Hz	\$PMTK314,0,0,0,1,0,0,0,0,0,0,0,0,0,0,0,0*29<CR><LF>
Only GSA at 1Hz	\$PMTK314,0,0,0,0,1,0,0,0,0,0,0,0,0,0,0,0*29<CR><LF>
Only GSV at 1Hz	\$PMTK314,0,0,0,0,0,1,0,0,0,0,0,0,0,0,0,0*29<CR><LF>
Only ZDA at 1Hz	\$PMTK314,0,0,0,0,0,0,0,0,0,0,0,0,0,0,0,1*29<CR><LF>
RMC, GGA, GSA	\$PMTK314,0,1,0,1,1,5,0,0,0,0,0,0,0,0,0,0*2C<CR><LF>

at 1Hz and GSV at 0.2Hz	
If the command is correct and executed, GNSS module will output message \$PMTK001,314,3*36<CR><LF>	

After the GNSS module is changed to higher baud rate or reduced NMEA sentence, the user can configure it to high update rate of position fix by the following commands.

Interval of position fix	Software command
Every 100ms (10Hz) ⁽¹⁾	\$PMTK220,100*2F<CR><LF>
Every 200ms (5Hz)	\$PMTK220,200*2C<CR><LF>
Every 500ms (2Hz)	\$PMTK220,500*2B<CR><LF>
Every 1000ms (1Hz)	\$PMTK220,1000*1F<CR><LF>
Every 2000ms (0.5Hz) ⁽²⁾	\$PMTK220,2000*1C<CR><LF>
If the command is correct and executed, GNSS module will output message \$PMTK001,220,3*30<CR><LF>	

Note 1: The minimum interval of position fix is 100ms, i.e. the maximum update rate is 10Hz.

Note 2: The current consumption is the same with the update rate of 1Hz.

5.6 Configure the static navigation parameter

The output position of GNSS module will keep the same and output speed will be zero if the actual speed is below the threshold of the static navigation parameter. This is useful for different applications. For example, the car stopped at a red light will get stationary GNSS position if the threshold is 1.5m/s. It is better to disable this function by setting threshold to 0 for pedestrian navigation.

The format of the software command is as below.

\$PMTK386,speed threshold*checksum<CR><LF>

The unit of speed threshold is meter per second. The range of speed threshold is from 0.1m/s to 2.0m/s. Value 0 is to disable the function.

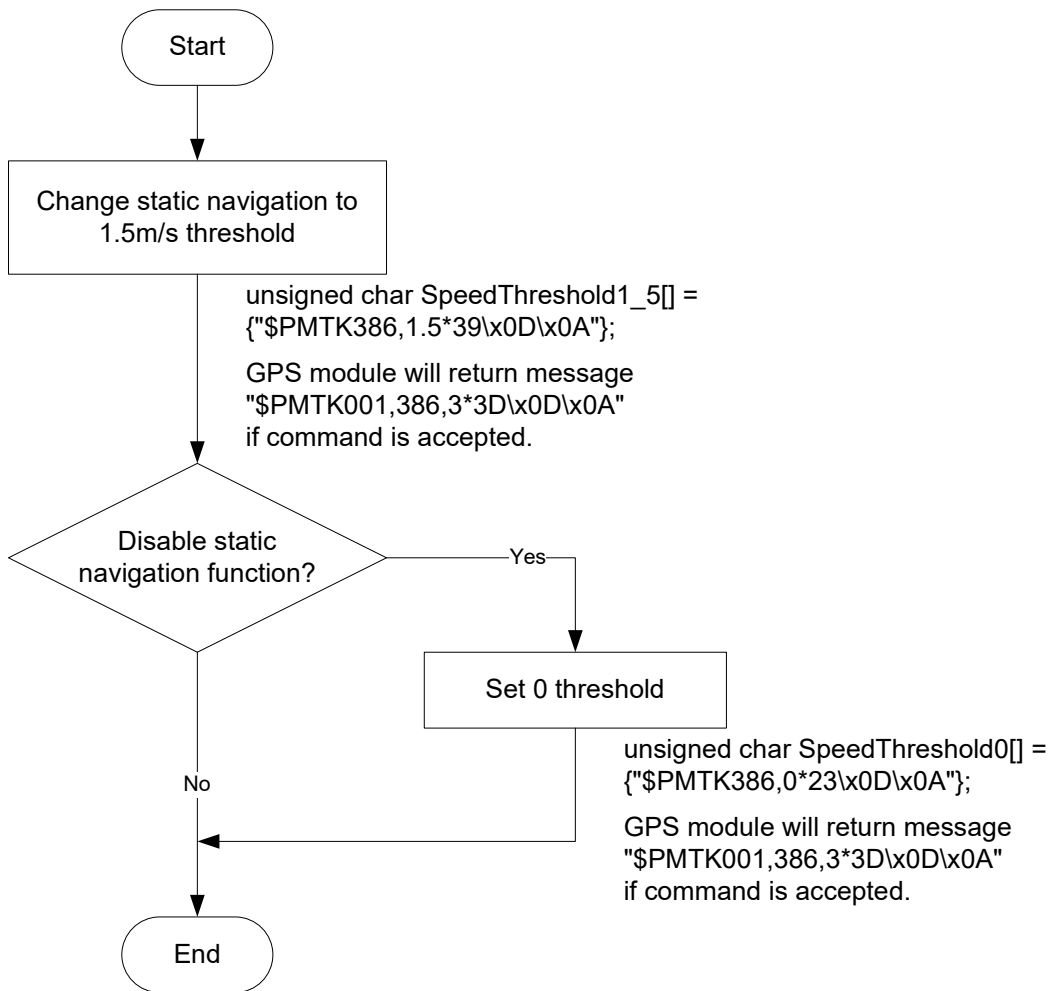

6 Pin assignment and descriptions

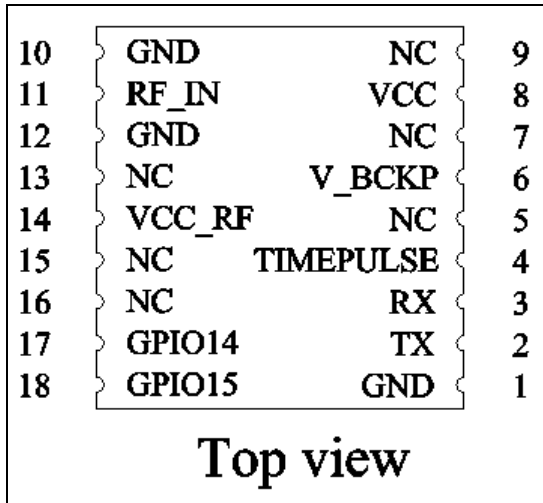

Table 6-1 Pin descriptions

Pin #	Name	Type	Description	Note
1	GND	P	Ground	
2	TX	O	Serial output (Default NMEA)	
3	RX	I	Serial input (Default NMEA)	
4	TIMEPULSE	O	Time pulse (1PPS, default 100 ms pulse/sec when 3D fix is available)	
5	NC		Not connect	
6	V_BCKP	P	Backup battery supply voltage This pin must be powered to enable the module.	1
7	NC		Not connect	
8	VCC	P	DC supply voltage	
9	NC		Not connect	
10	GND	P	Ground	
11	RF_IN	I	GNSS RF signal input	
12	GND	P	Ground	
13	NC		Not connect	
14	VCC_RF	O	Output voltage for active antenna	
15	NC		Not connect	
16	NC		Not connect	
17	GPIO14	I/O	General purpose I/O	
18	GPIO15	I/O	General purpose I/O	

<Note>

- In order to get the advantage of hybrid ephemeris prediction, this pin must be always powered during the period of effective ephemeris prediction.

7 DC & Temperature characteristics

7.1 Absolute maximum ratings

Parameter	Symbol	Ratings	Units
Input Voltage	VIN	4.3	V
Input Backup Battery Voltage	V_BCKP	4.3	V
VCC_RF Output Current	Iout	50	mA
Operating Temperature Range	Topr	-40 ~ 85	°C
Storage Temperature Range	Tstg	-40 ~ 85	°C

7.2 DC Electrical characteristics

Parameter	Symbol	Conditions	Min.	Typ.	Max.	Units
Input Voltage	VCC		3.0	3.3	4.3	V
Input Backup Battery Voltage	V_BCKP		2.0		4.3	V
VCC_RF Output Voltage	VCC_RF		2.7	2.8	2.9	V
Supply Current	Iss	VCC = 3.3V, w/o active antenna,			156 ⁽¹⁾	mA
		Peak		28		mA
		Acquisition		20 ⁽²⁾		mA
		Tracking		365		uA
Standby						
Backup Battery Current	Ibat	VIN = 0V		7		uA
VCC_RF Output Current	Iout	VIN = 3.3V			30	mA
High Level Input Voltage	V _{IH}		2.0		3.6	V
Low Level Input Voltage	V _{IL}		-0.3		0.8	V
High Level Input Current	I _{IH}	no pull-up or down	-1		1	uA
Low Level Input Current	I _{IL}	no pull-up or down	-1		1	uA
High Level Output Voltage	V _{OH}		2.4		3.3	V
Low Level Output Voltage	V _{OL}				0.4	V
High Level Output Current	I _{OH}			2		mA
Low Level Output Current	I _{OL}			2		mA

Note 1. This happens when downloading AGPS data to MC-1010-G.

Note 2. Measured when position fix (1Hz) is available, input voltage is 3.3V and the function of self-generated ephemeris prediction is inactive. For different input voltage, the current consumption is as below chart. This is because MC-1010-G has a built-in DC/DC converter.

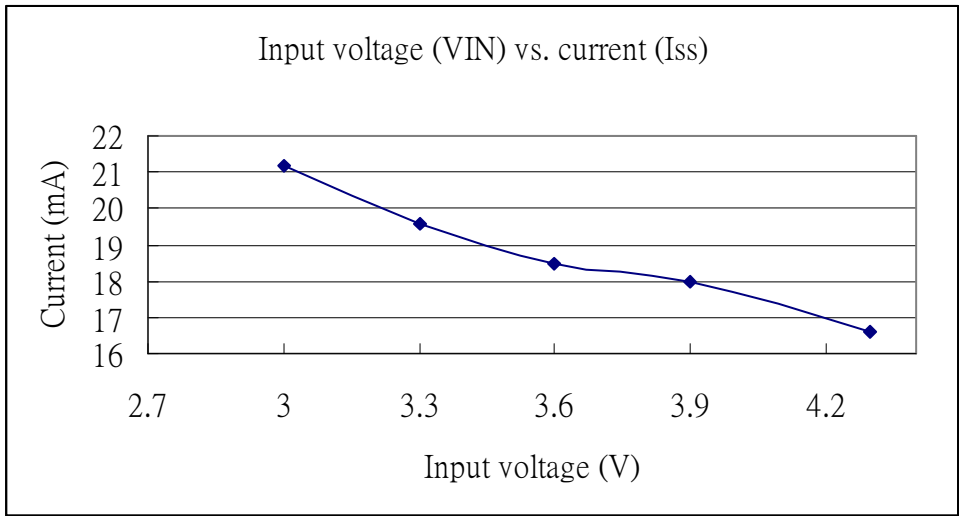

7.3 Temperature characteristics

Parameter	Symbol	Min.	Typ.	Max.	Units
Operating Temperature	Topr	-40	-	85	°C
Storage Temperature	Tstg	-40	25	85	°C

8 Mechanical specification
 8.1 Outline dimensions

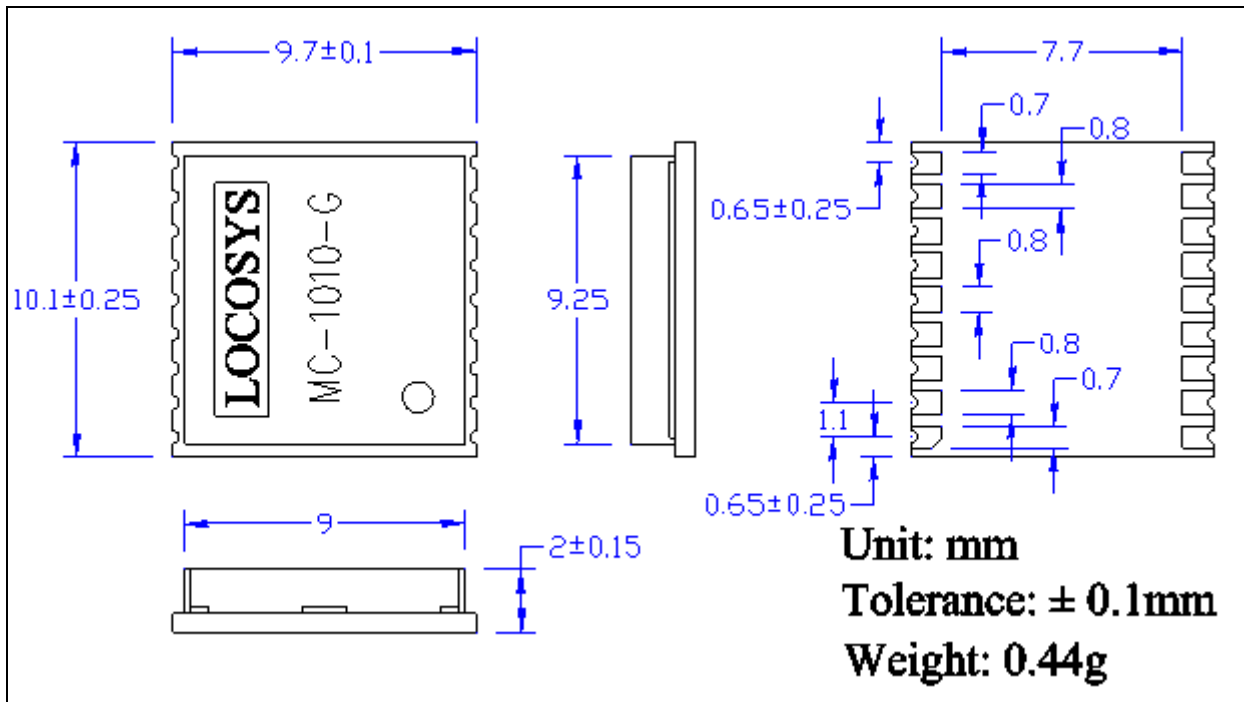

8.2 Recommended land pattern dimensions

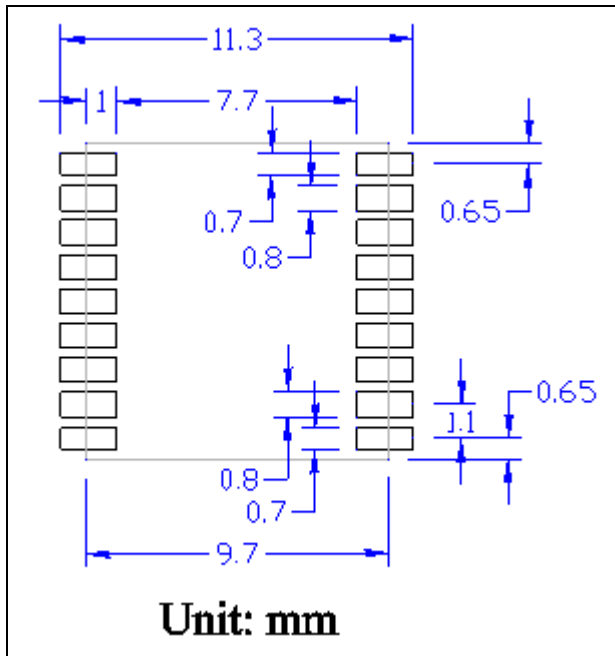

9 Reel Packing information

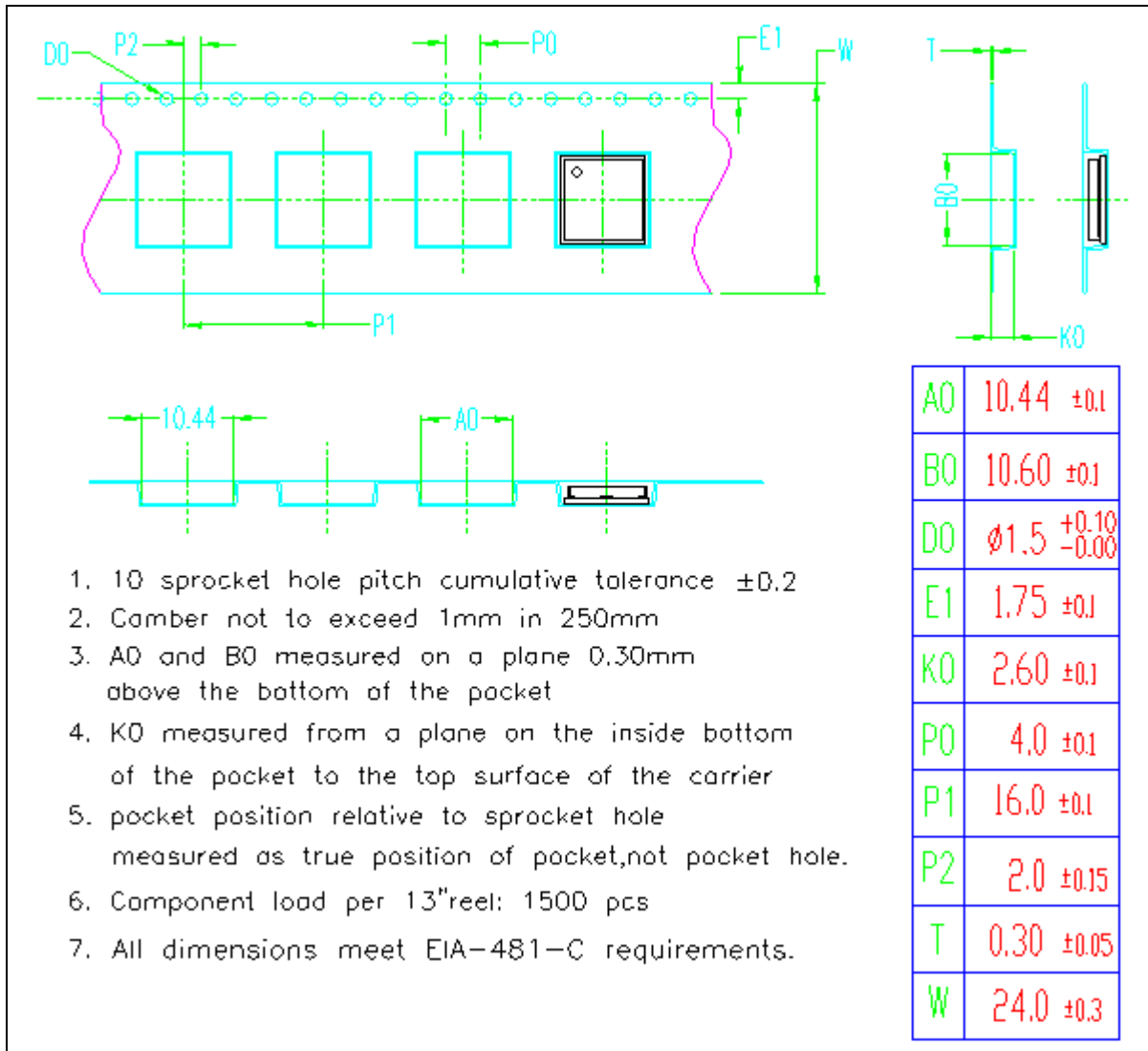

Document change list

Revision 1.0

- First release on March 18, 2013.

Revision 1.0 to revision 1.1 (November 14, 2013)

- Add description of the active antenna gain on page 2.
- Revised the connection of pin 9 from GND to NC in the Fig 3-2.

Revision 1.1 to revision 1.2 (April 29, 2020)

- Added “Note 1” in the section 4.