



Datasheet of LU2303x-Vx

Version 1.0

2023/6/2

LOCOSYS Technology Inc.

20F.-13, No.79, Sec. 1, Xintai 5th Rd.,

Xizhi District, New Taipei City 221, Taiwan

 886-2-8698-3698

 886-2-8698-3699

 www.locosystech.com

Contents

1. Introduction.....	3
2. Features.....	3
3. Application	3
4. GNSS Performance.....	4
5. Software interface.....	5
5.1 NMEA output message	5
5.2 Proprietary commands	11
6. LED indicator	13
7. Pin assignment and descriptions.....	14
8. DC & Temperature characteristics.....	16
8.1 DC Electrical characteristics.....	16
8.2 Temperature characteristics	16
9. Mechanical specification	17
9.1 LU23030-Vx (USB interface)	17
9.2 LU23032-Vx (RS232 interface)	17
9.3 LU23036-Vx (RS232 interface)	18
10. Ordering information.....	19
11. Document change list	20

Table Index

Table 1: Receiver Key Features	4
Table 2: NMEA output message	5
Table 3: GGA Data Format	5
Table 4: Position Fix Indicators	6
Table 5: GLL Data Format	6
Table 6: GSA Data Format	7
Table 7: Mode 1	7
Table 8: Mode 2	7
Table 9: GNSS system ID	7
Table 10: GSV Data Format	8
Table 11: RMC Data Format	9
Table 12: VTG Data Format	10
Table 13: GST Data Format	10
Table 14: Light indication	13

Figure Index

Figure 1: Pin Assignment	13
Figure 2: USB Pin Assignment	14
Figure 3: PS2 Pin Assignment	14
Figure 4: RJ11 Pin Assignment	15



1 Introduction

LU2303x-Vx series products are high-performance dual-band GNSS receivers (also known as GNSS mouse) that are capable of tracking all global civil navigation systems (GPS, GLONASS, BDS, GALILEO, QZSS and IRNSS). The GNSS mouse will acquire both L1 and L5 signals at a time while providing the better position accuracy. It can provide user with fast Time-To-First-Fix, superior sensitivity and low power consumption. Its far-reaching capability meets the sensitivity requirements of car navigation as well as other location-based applications.

2 Features

- Concurrent reception of L1 and L5 band signals
- Multi-Constellation GPS, GLONASS, Galileo, BeiDou, QZSS and IRNSS (NavIC)
- Support for SBAS ranging, WAAS, EGNOS, MSAS and GAGAN
- Fast TTFF at low signal level
- Free hybrid ephemeris prediction to achieve faster cold start
- Smart jammer detection and suppression
- Build-in super capacitance to reserve system data for rapid satellite acquisition
- Brand New Design with improved visibility on signal LEDs
- Waterproof

3 Application

- Personal positioning and navigation
- Automotive navigation
- Marine navigation

4 GNSS Performance

Frequency	LU23030-V2 LU23032-V2 LU23036-V2	GPS/QZSS: L1 C/A, L5C GLONASS: L1OF BEIDOU: B1I, B2a GALILEO: E1, E5a
	LU23030-V3 LU23032-V3 LU23036-V3	GPS/QZSS: L1 C/A GLONASS: L1OF BEIDOU: B1I GALILEO: E1 IRNSS L5
Channels	Support 135 channels	
Update rate	1Hz default, up to 10Hz	
Acquisition Time	Hot start (Open Sky)	2s (typical)
	Cold Start (Open Sky)	28s (typical) without AGPS
Position Accuracy	LU2303x-V2	Autonomous: 1.5m ⁽¹⁾ (CEP)
	LU2303x-V3	Autonomous: 2.5m ⁽¹⁾ (CEP)
Datum	WGS-84 (default)	
Max. Altitude	< 18,000 m	
Max. Velocity	< 500 m/s	
Protocol Support	NMEA 0183 ver. 4.1	115200 bps , 8 data bits, no parity, 1 stop bits (default) 1Hz: GGA, GLL, GSA, GSV, RMC, VTG, GST

Table 1: Receiver Key Features

<Note>

1. Open sky, demonstrated with a good antenna.
2. The maximum altitude of the balloon mode is 80,000 m.
3. Both baud rate and output message rate are configurable to be factory default.

5 Software interface

5.1 NMEA output message

NMEA record	Description
GGA	Global positioning system fixed data
GLL	Geographic position - latitude/longitude
GSA	GNSS DOP and active satellites
GSV	GNSS satellites in view
RMC	Recommended minimum specific GNSS data
VTG	Course over ground and ground speed
GST	Estimated error in position solution

Table 2: NMEA output message

- GGA--- Global Positioning System Fixed Data

Table 5.1-1 contains the values for the following example:

\$GNGGA,061300.000,2503.71255,N,12138.74493,E,2,38,0.44,121.12,M,15.32,M,,*7E

Name	Example	Units	Description
Message ID	\$GNGGA		GGA protocol header
UTC Time	061300.000		hhmmss.sss
Latitude	2503.71255		ddmm.mmmmm
N/S indicator	N		N=north or S=south
Longitude	12138.74493		dddmm.mmmmm
E/W Indicator	E		E=east or W=west
Position Fix Indicator	2		See Table 4
Satellites Used	38		Number of satellites in use
HDOP	0.44		Horizontal Dilution of Precision (meters)
MSL Altitude	121.12	meters	Antenna Altitude above/below mean-sea-level (geoid) (in meters)
Units	M	meters	Units of antenna altitude, meters
Geoidal Separation	15.32	meters	
Units	M	meters	Units of geoidal separation, meters
Age of diff. GNSS data		second	Null fields when DGPS is not used
Diff. Ref. Station ID			Differential reference station ID, 0000-1023
Checksum	*7E		Checksum
<CR> <LF>			End of message termination

Table 3: GGA Data Format

Value	Description
0	No position fix
1	Autonomous GNSS fix
2	Differential GNSS fix
4	RTK fixed
5	RTK float
6	Estimated/Dead reckoning fix

Table 4: Position Fix Indicators

- **GLL---** Geographic Position – Latitude/Longitude

Table 5.1-2 contains the values for the following example:

\$GNGLL,2503.71255,N,12138.74493,E,061300.000,A,D*42

Name	Example	Units	Description
Message ID	\$GNGLL		GLL protocol header
Latitude	2503.71255		ddmm.mmmmm
N/S indicator	N		N=north or S=south
Longitude	12138.7493		dddmm.mmmmm
E/W indicator	E		E=east or W=west
UTC Time	061300.000		hhmmss.sss
Status	A		A=data valid or V=data not valid
Mode	D		N = No position fix A = Autonomous GNSS fix D = Differential GNSS fix R = RTK fixed F = RTK float E = Estimated/Dead reckoning fix
Checksum	*42		
<CR> <LF>			End of message termination

Table 5: GLL Data Format

- **GSA---**GNSS DOP and Active Satellites

Table 5.1-3 contains the values for the following example:

\$GNRSA,A,3,19,195,17,06,20,11,09,02,194,12,05,04,0.81,0.44,0.68,1*04

\$GNRSA,A,3,14,,,,,,,,,0.81,0.44,0.68,1*03

\$GNRSA,A,3,66,81,88,65,79,82,,,,,,,,,0.81,0.44,0.68,2*0B

\$GNRSA,A,3,03,15,34,27,30,,,,,,,,,0.81,0.44,0.68,3*02

\$GNRSA,A,3,33,40,07,10,38,28,08,41,13,14,43,42,0.81,0.44,0.68,4*0B

\$GNGSA,A,3,11,39,,,,,,,,,0.81,0.44,0.68,4*09

Name	Example	Units	Description
Message ID	\$GNGSA		GSA protocol header
Mode 1	A		See Table 7
Mode 2	3		See Table 8
ID of satellite used	19		SV on Channel 1
ID of satellite used	195		SV on Channel 2
ID of satellite used			SV on Channel 12
PDOP	0.81		Position Dilution of Precision
HDOP	0.44		Horizontal Dilution of Precision
VDOP	0.68		Vertical Dilution of Precision
GNSS system ID	1		See Table 9
Checksum	*04		
<CR> <LF>			End of message termination

Table 6: GSA Data Format

Value	Description
M	Manually set to operate in 2D or 3D mode
A	Automatically switching between 2D or 3D mode

Table 7: Mode 1

Value	Description
1	No position fix
2	2D fix
3	3D fix

Table 8: Mode 2

Value	Description
1	GPS
2	GLONASS
3	GALILEO
4	BEIDOU
6	IRNSS

Table 9: GNSS system ID

- GSV---GNSS Satellites in View

Table 5.1-4 contains the values for the following example

```
$GPGSV,4,1,15,196,73,108,46,19,72,077,47,195,71,061,47,199,59,164,22,1*5B
$GPGSV,4,2,15,17,54,115,47,06,49,003,48,20,44,248,47,11,36,306,46,1*6E
$GPGSV,4,3,15,09,35,079,45,02,31,307,45,194,28,175,43,12,25,302,43,1*52
$GPGSV,4,4,15,05,14,230,38,04,14,051,38,14,11,173,43,1*53
$GLGSV,2,1,07,66,71,107,44,81,39,356,48,88,36,067,47,67,33,187,,1*7B
$GLGSV,2,2,07,65,25,033,46,79,17,262,47,82,08,315,43,1*46
$GAGSV,2,1,05,03,49,122,45,15,47,342,45,34,37,056,43,27,33,273,43,7*7B
$GAGSV,2,2,05,30,30,208,41,7*49
$GBGSV,4,1,14,33,72,072,50,40,63,187,48,07,63,217,45,10,63,251,45,1*74
$GBGSV,4,2,14,38,58,328,48,28,56,353,49,08,52,306,44,41,47,200,48,1*75
$GBGSV,4,3,14,13,47,291,45,14,45,047,45,43,44,092,47,42,20,040,42,1*71
$GBGSV,4,4,14,11,20,105,41,39,11,172,42,1*78
```

Name	Example	Units	Description
Message ID	\$GPGSV		GSV protocol header GP=GPS/QZSS, GL=GLONSS, GA=GALILEO, GB=BEIDOU, GI=IRNSS.
Total number of messages	4		Range 1 to 9
Message number	1		Range 1 to 9
Satellites in view	15		
Satellite ID	196		Channel 1
Elevation	73	degrees	Channel 1 (Range 00 to 90)
Azimuth	108	degrees	Channel 1 (Range 000 to 359)
SNR (C/No)	46	dB-Hz	Channel 1 (Range 00 to 99, null when not tracking)
Satellite ID	199		Channel 4
Elevation	59	degrees	Channel 4 (Range 00 to 90)
Azimuth	164	degrees	Channel 4 (Range 000 to 359)
SNR (C/No)	22	dB-Hz	Channel 4 (Range 00 to 99, null when not tracking)
Signal ID	1		GPS/QZSS: L1 C/A=1 GLONASS: L1 C/A=1 GALILEO: E1=7 BEIDOU: B1=1, B1C=3
Checksum	*5B		
<CR> <LF>			End of message termination

Table 10: GSV Data Format

- **RMC---Recommended Minimum Specific GNSS Data**

Table 5.1-5 contains the values for the following example:

\$GNRMC,061300.000,A,2503.71255,N,12138.74493,E,0.01,30.70,150622,,D,V*38

Name	Example	Units	Description
Message ID	\$GNRMC		RMC protocol header
UTC Time	061300.000		hhmmss.sss
Status	A		A=data valid or V=data not valid
Latitude	2503.71255		ddmm.mmmm
N/S Indicator	N		N=north or S=south
Longitude	12138.74493		dddmm.mmmmm
E/W Indicator	E		E=east or W=west
Speed over ground	0.001	knots	True
Course over ground	30.70	degrees	
Date	150622		ddmmyy
Magnetic variation		degrees	
Variation sense			E=east or W=west
Mode	D		N = No position fix A = Autonomous GNSS fix D = Differential GNSS fix R = RTK fixed F = RTK float E = Estimated/Dead reckoning fix
Navigational status indicator	V		S = Safe C = Caution U = Unsafe V = Void
Checksum	*38		
<CR> <LF>			End of message termination

Table 11: RMC Data Format

- **VTG---Course Over Ground and Ground Speed**

Table 5.1-6 contains the values for the following example:

\$GNVTG,30.70,T,,M,0.01,N,0.01,K,D*12

Name	Example	Units	Description
Message ID	\$GNVTG		VTG protocol header
Course over ground	30.70	degrees	Measured heading

Reference	T		True
Course over ground		degrees	Measured heading
Reference	M		Magnetic
Speed over ground	0.001	knots	Measured speed
Units	N		Knots
Speed over ground	0.001	km/hr	Measured speed
Units	K		Kilometer per hour
Mode	D		N = No position fix A = Autonomous GNSS fix D = Differential GNSS fix R = RTK fixed F = RTK float E = Estimated/Dead reckoning fix
Checksum	*12		
<CR> <LF>			End of message termination

Table 12: VTG Data Format

- GST---Estimated error in position solution

Table 5.1-7 contains the values for the following example:

\$GNGST,061300.000,2.6,1.9,1.6,169.8,1.9,1.6,6.8*71

Name	Example	Units	Description
Message ID	\$GNGST		GST protocol header
UTC Time	061300.000		hhmmss.sss
RangeRMS	2.6	meters	RMS value of the standard deviation of the ranges
stdMajor	1.9	meters	Standard deviation of semi-major axis of error ellipse
stdMinor	1.6	Meters	Standard deviation of semi-minor axis of error ellipse
Orient	169.8	degrees	Orientation of semi-major axis of error ellipse
stdLat	1.9	meters	Standard deviation of latitude error
stdLong	1.6	meters	Standard deviation of longitude error
stdAlt	6.8	meters	Standard deviation of altitude error
Checksum	*71		
<CR> <LF>			End of message termination

Table 13: GST Data Format

5.2 Proprietary commands

The commonly used commands are in the following.

5.2.1 ID: 004

[Description]

Hot Start. Use the available data in the NVRAM.

[Data Field]

\$PAIR004*CS<CR><LF>

[Return]

PAIR_ACK for send result.

[Example]

Send:

\$PAIR004*3E\r\n

Response:

\$PAIR001,004,0*3F\r\n ==> Success

5.2.2 ID: 005

[Description]

Warm Start. Not using Ephemeris data at the start.

[Data Field]

\$PAIR005*CS<CR><LF>

[Return]

PAIR_ACK for send result.

[Example]

Send:

\$PAIR005*3F\r\n

Response:

\$PAIR001,005,0*3E\r\n ==> Success

5.2.3 ID: 006

[Description]

Cold Start. Not using the Position, Almanac and Ephemeris data at the start.

[Data Field]

\$PAIR006*CS<CR><LF>

[Return]

PAIR_ACK for send result.

[Example]

Send:

\$PAIR006*3C\r\n

Response:

\$PAIR001,006,0*3D\r\n ==> Success

6 LED indicator



Figure 1: Pin Assignment

LED	Color	Descriptions
1	Green	TX Indicator
2	Red	Power Indicator
3	Blue	PPS Indicator

Note: When GNSS get a 3D fixed.

Table 14: Light indication

7 Pin assignment and descriptions

● LU23030-Vx

Pin#	Name	Type	Description
1	VBUS	I	+5V
2	D-		Data -
3	D+		Data +
4	GND	P	Ground

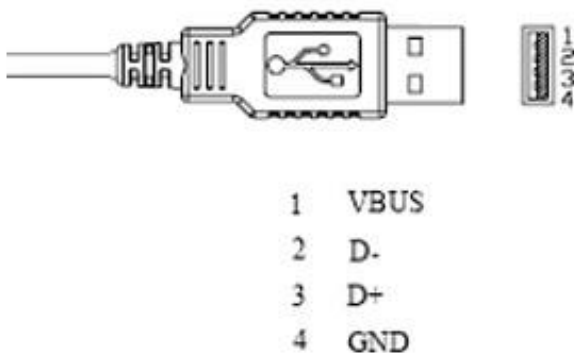

Figure 2: USB Pin Assignment

● LU23032-Vx

Pin#	Name	Type	Description
1	GND	P	Ground
2	VDD	I	Power input
3	NC		Not connect
4	RX	I	Data input (RS232 level)
5	TX	O	Data input (RS232 level)
6	NC		Not connect

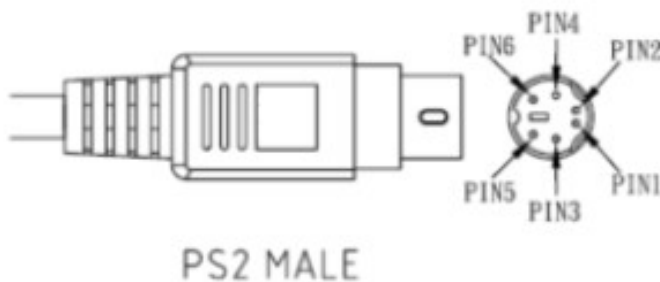

Figure 3: PS2 Pin Assignment

● LU23036-Vx

Pin#	Name	Type	Description
1	NC		Not connect
2	GND	P	Ground
3	RX	I	Data input (RS232 level)
4	TX	O	Data input (RS232 level)
5	VDD	I	Power input
6	NC		Not connect

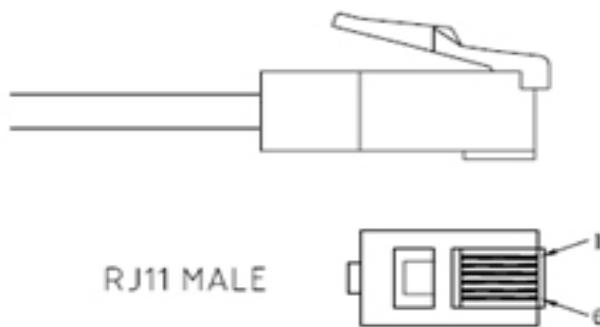

Figure 4: RJ11 Pin Assignment

8 DC & Temperature characteristics

8.1 DC Electrical characteristics

Parameter	Symbol	Product	Min.	Typ.	Max.	Units	
Input voltage	VCC	LU23030-Vx	4.75	5.0	5.25	V	
		LU23032-Vx	4.75	5.0	5.25		
		LU23036-Vx	4.75	5.0	5.25		
Input current ⁽¹⁾	Icc	LU23030-V2		76		mA	
		LU23032-V2		69			
		LU23036-V2		69			
			LU23030-V3		52		mA
			LU23032-V3		46		
			LU23036-V3		46		

Note 1: Measured when position fix (1Hz) is available.

8.2 Temperature characteristics

Parameter	Symbol	Min.	Typ	Max.	Units
Operating Temperature	Topr	-10	-	60	°C
Storage Temperature	Tstg	-10	25	60	°C

9 Mechanical specification

9.1 LU23030-Vx (USB interface)

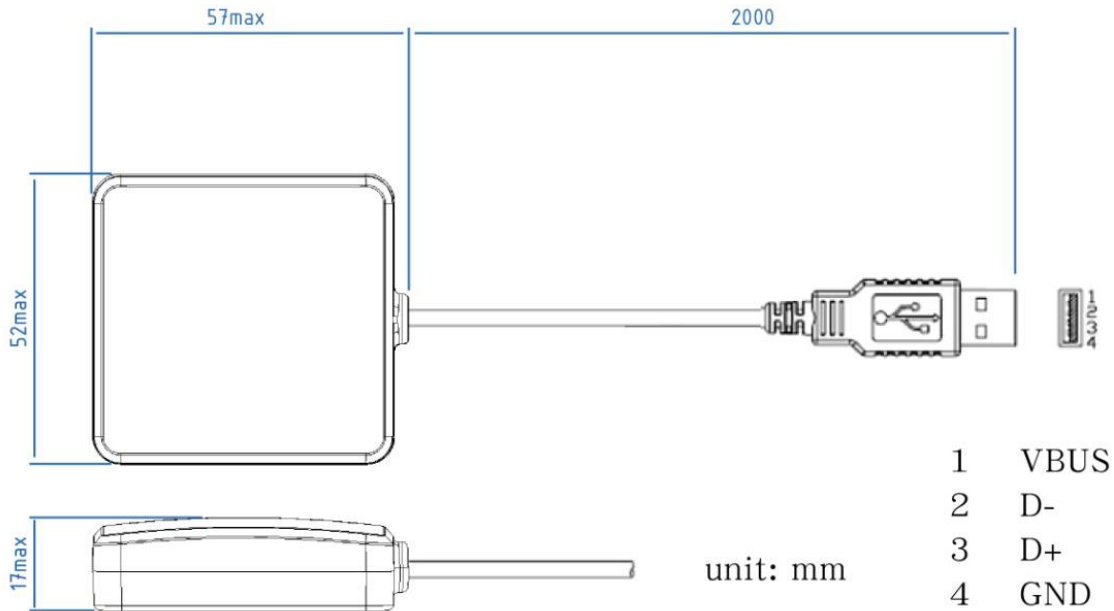

9.2 LU23032-Vx (RS232 interface)

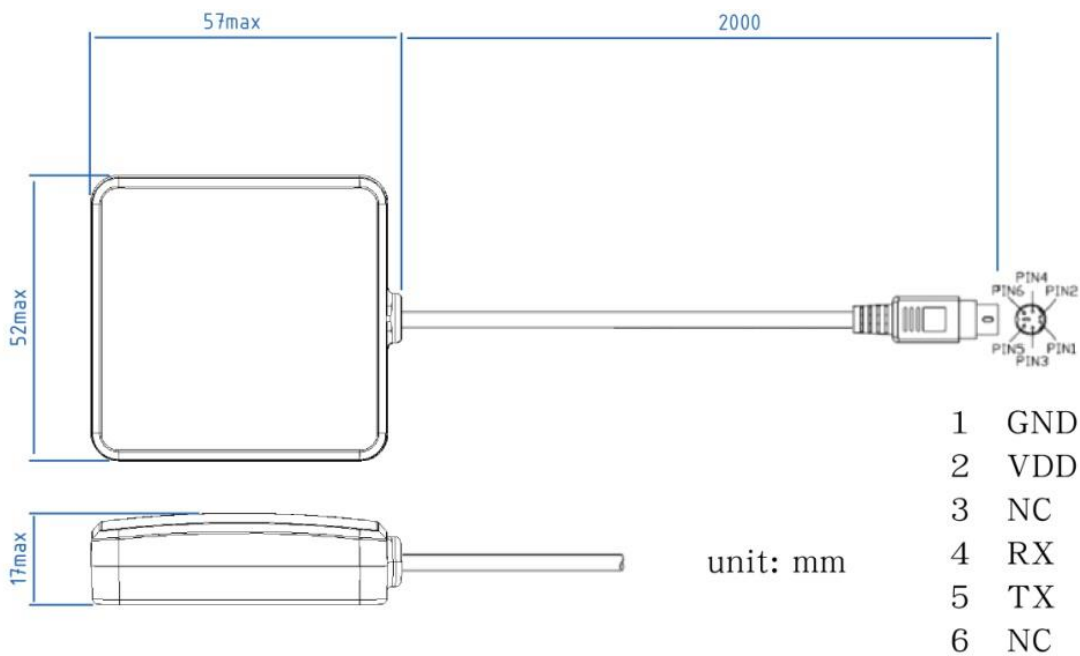

9.3 LU23036-Vx (RS232 interface)

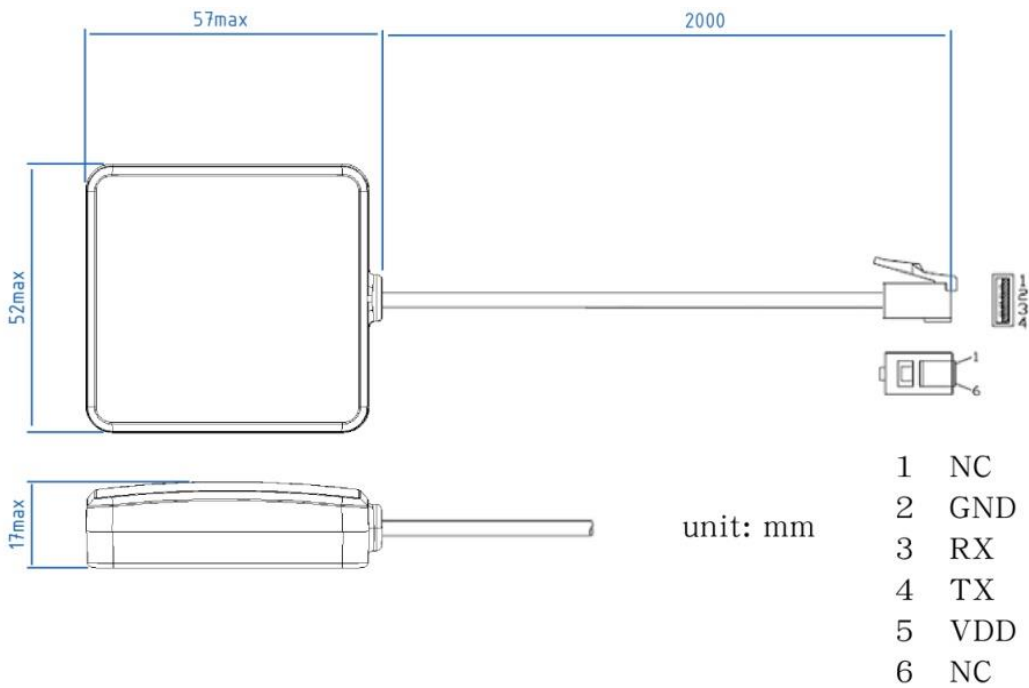

10 Ordering information

Product name	Description	Remark
LU23030-V2	Dual-frequency multi-constellation GNSS mouse / 2m, USB	GPS/QZSS: L1 C/A, L5C GLONASS: L1OF BEIDOU: B1I, B2a GALILEO: E1, E5a
LU23032-V2	Dual-frequency multi-constellation GNSS mouse / 2m, PS2	
LU23036-V2	Dual-frequency multi-constellation GNSS mouse / 3m, RJ11	
LU23030-V3	Dual-frequency multi-constellation GNSS mouse / 2m, USB	GPS/QZSS: L1 C/A GLONASS: L1OF BEIDOU: B1I GALILEO: E1 IRNSS: L5
LU23032-V3	Dual-frequency multi-constellation GNSS mouse / 2m, PS2	
LU23036-V3	Dual-frequency multi-constellation GNSS mouse / 3m, RJ11	

11 Document change list

Revision 0.1 alpha

- For internal review on March 31, 2023.

Revision 1.0 (June 2, 2023)

- Changed the current of LU23030-V2 from 73mA to 76mA in section 8.1.
- Changed the current of LU23032-V2 、 LU23036-V2 from 67mA to 69mA in section 8.1.
- Changed the current of LU23030-V3 from 54mA to 52mA in section 8.1.
- Changed the current of LU23032-V3 、 LU23036-V3 from 43mA to 46mA in section 8.1.
- Changed the operating and storage temperature (Min.) from -20°C to -10 °C in section 8.2.