

Product Name	Description	Version
LU23031-V2	Dual-frequency multi-constellation GNSS receiver	0.1
LU23031-V2e	Dual-frequency multi-constellation GNSS receiver with e-compass	



## 1 Introduction

LU23031-V2/LU23031-V2e both are dual-frequency GNSS (RTK)\* receiver designed for Pixhawk(PX4)-based platform UAV. The receiver is capable of concurrently tracking all global civil navigation systems, including GPS, GLONASS, GALILEO, BEIDOU and QZSS. It acquires both L1 and L5 signals at a time while providing the centimeter-level RTK positioning accuracy.

The built-in lightweight helical antenna not only enhances GNSS (RTK)\* positioning stability, but also increases the flight time of the drone. The fast Time-To-First-Fix, GNSS (RTK)\* convergence, superior sensitivity, low power consumption make it a better choice for Pixhawk(PX4)-based platform UAV.

\* Note: RTK is optional.

## 2 Features

- Concurrent reception of L1 and L5 band signals
- Support GPS, GLONASS, BEIDOU, GALILEO, QZSS
- Capable of SBAS (WAAS, EGNOS, MSAS, GAGAN)
- Support 135-channel GNSS
- Fast TTFF at low signal level
- Free hybrid ephemeris prediction to achieve faster cold start
- Default 5Hz, up to 10 Hz update rate\*
- Build-in super capacitor to reserve system data for rapid satellite acquisition
- Three LED indicator for Power, PPS and Data transmit
- LU23031-V2e integrated with e-compass module (3-axis magnetometer)

\*Note: SBAS support 5Hz only.

### 3 Application

- Unmanned aerial vehicle (UAV) positioning and navigation

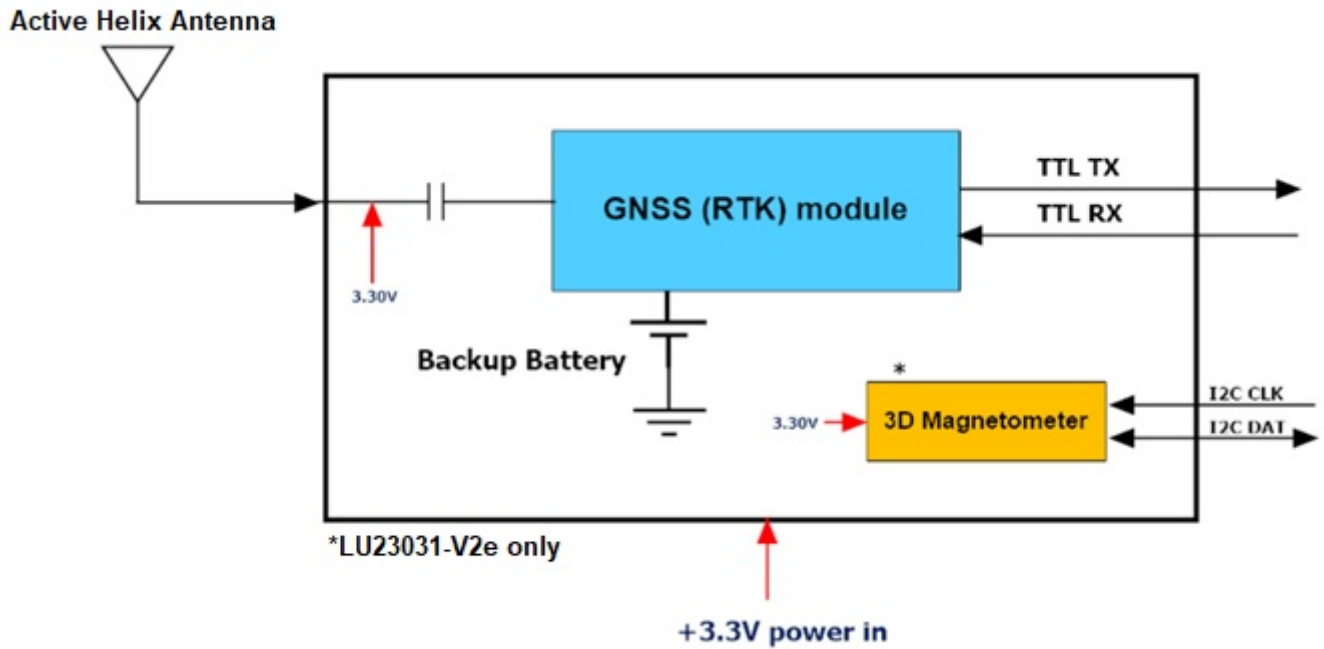

Fig 3-1 System block diagram of LU23031-V2 , LU23031-V2e

## 4 Pin assignment and LED description



No	Name	Description
LED 1	TX LED	Green, GNSS data transmit indicator
LED 2	Power LED	Red, Power indicator
LED 3	PPS LED	Blue, PPS indicator

Pin No	Name	Type	Description
1	VCC	P	DC supply voltage 3.3V ~ 5.0V input
2	GNSS_RX	I/O	Receive Data Input
3	GNSS_TX	I/O	Transmit Data Output
4	GNSS_PPS	O	GNSS pulse per second, 100ms pulse width, 1.8V DC
5	NC		NC
6	NC		NC
7	I2C_CLK	I/O	Magnetometer's I2C serial clock
8	I2C_DAT	I/O	Magnetometer's I2C serial data
9	GND	P	Ground

#### 4.1 Cable pin assignment



NO	Pin No	Name	Type	Description
1	Red	VCC	P	Red, DC supply voltage 3.3V ~ 5.0V input
2	Green	GNSS_RX	I/O	Green, Receive Data Input
3	Yellow	GNSS_TX	I/O	Yellow, Transmit Data Output
4	NC			
5	NC			
6	Black	GND	P	Black, Ground



NO	Pin No	Name	Type	Description
1	Red	VCC	P	Red, DC supply voltage 3.3V ~ 5.0V input
2	Green	GNSS_RX	I/O	Green, Receive Data Input
3	Yellow	GNSS_TX	I/O	Yellow, Transmit Data Output
4	White	I2C_CLK	I/O	White, Magnetometer's I2C serial clock
5	Blue	I2C_DAT	I/O	Blue, Magnetometer's I2C serial data
6	Black	GND	P	Black, Ground

## 5 GNSS receiver

Frequency	GPS/QZSS: L1 C/A, L5C GLONASS: L1OF BEIDOU: B1I, B2a GALILEO: E1, E5a	
Channels	Support 135 channels	
Update rate	5Hz default, up to 10Hz	
Acquisition Time	Hot start (Open Sky)	2s (typical)
	Cold Start (Open Sky)	28s (typical) without AGPS
PPS	100ms pulse width, 1.8Vdc	
Datum	WGS-84 (default)	
Max. Altitude	< 18,000 m	
Max. Velocity	< 500 m/s	
Protocol Support	UBX	230400 bps, 8 data bits, no parity, 1 stop bits (default) 5Hz:UBX-NAV-PVT,UBX-NAV-DOP 1Hz: UBX-NAV-TIMEGPS

6 DC & Temperature characteristics

6.1 DC Electrical characteristics

Parameter	Symbol	Min.	Typ.	Max.	Units
Input voltage	V <sub>CC</sub>	3.3	3.3	5.0	V
Input current <sup>(1)</sup>	I <sub>CC</sub>		67	87	mA
High Level Input Voltage	V <sub>IH</sub>	0.7*V <sub>CC</sub>		V <sub>CC</sub>	V
Low Level Input Voltage	V <sub>IL</sub>	0		0.2*V <sub>CC</sub>	V
High Level Output Voltage	V <sub>OH</sub>	V <sub>CC</sub> -0.4			V
Low Level Output Voltage	V <sub>OL</sub>			0.4	V
High Level Output Current	I <sub>OH</sub>		4		mA
Low Level Output Current	I <sub>OL</sub>		4		mA

Note 1: Measured when position fix (1Hz) is available, the function of self-generated ephemeris prediction is inactive.

6.2 Temperature characteristics

Parameter	Symbol	Min.	Typ.	Max.	Units
Operating Temperature	T <sub>opr</sub>	-20	-	60	°C
Storage Temperature	T <sub>stg</sub>	-20	-	65	°C

Note: The operating and storage temperature of the built-in micro battery are -20 ~ +60 °C.

7 Mechanical specification



8 Ordering information

Product name	Description	Remark
<b>LU23031-V2</b>	Dual-frequency multi-constellation GNSS receiver	GPS/QZSS: L1 C/A, L5C GLONASS: L1OF GALILEO: E1, E5a BEIDOU: B1I, B2a
<b>LU23031-V2e</b>	Dual-frequency multi-constellation GNSS receiver <b>with e-compass</b>	GPS/QZSS: L1 C/A, L5C GLONASS: L1OF GALILEO: E1, E5a BEIDOU: B1I, B2a

## 9 Suggesting mounting area



## 10 Packing information: Receiver + Helix antenna +Connector



Note: LU23031-V2 (include **Cable 1**)  
LU23031-V2e (include **Cable 2**)



## Document change list

### Revision 0.1

- Preliminary release on December 27, 2021.