

Product name	Description	Version
LS23092-G2	Multiple GNSS mouse/ STA8088, 2m,PS2,9600BPS	1.0
LS23093-G2	Multiple GNSS mouse/ STA8088, 3m,RJ11,9600BPS	
LS23095-G2	Multiple GNSS mouse/ STA8088, 5m,PS2 with lock,9600BPS	
LS23096-G2	Multiple GNSS mouse/ STA8088, 3m,RJ11,9600BPS	

Note: LS23096-G2 is most popular. We recommend customers to use for new design.

## Datasheet of GPS+GLONASS mouse, LS2309x-G2 series



LS23092-G2 LS23093-G2 LS23095-G2 LS23096-G2

### 1 Introduction

LS2309x-G2 series products are complete GNSS receivers (also known as GNSS mouse) based on the proven technology found in LOCOSYS GNSS module ST-1612-G that uses STMicro chip solution. The GNSS mouse will track up to 32 satellites at a time while providing fast Time-To-First-Fix, one-second navigation updates and low power consumption. It can provide you with superior sensitivity and performance even in urban canyon and dense foliage environment. Its far-reaching capability meets the sensitivity requirements of car navigation as well as other location-based applications.

### 2 Features

- STMicroelectronics TeseoII™ family single chip solution.
- Support GPS/GLONASS/GALILEO/QZSS navigation systems.
- Based on chips compliant with "AEC-Q100" qualification.(using STM 8088GA only)
- Manufactured complied with RoHS & ISO/TS 16949.
- Fast TTF at low signal level.
- Capable of SBAS.
- Built-in 3-state jammer barrier.
- Support of ST-AGPS™ Multimode Assisted GPS (extended ephemeris solution)
- Build-in micro battery to reserve system data for rapid satellite acquisition.
- Magnet for mounting on the car.
- Skid resistant pad on the bottom.
- High accuracy time pulse (1PPS)

- Waterproof.

### 3 Application

- Personal positioning and navigation.
- Automotive navigation.
- Marine navigation.

### 4 GNSS specification

Chip	STA8088FG series	
Frequency	GPS, GALILEO, QZSS: L1 1575.42MHz, C/A code GLONASS: L1 1598.0625MHz ~ 1605.375MHz, C/A code	
Channels	Support 32 channels	
Update rate	1Hz default, up to 10Hz.	
Acquisition Time	Cold Start (Open Sky)	32s (typical)
Position Accuracy	Autonomous	1.6m CEP
Max. Altitude	< 18,000 m ( 60000 ft )	
Max. Velocity	< 515 m/s ( 1000 knots )	
Protocol Support	NMEA 0183 ver 3.01	9600 bps <sup>(1)</sup> , 8 data bits, no parity, 1 stop bits (default) 1Hz: GGA, GLL, GSA, GSV, RMC, VTG

Note 1: Both baud rate and output message rate are configurable to be factory default.

### 5 LED indicator

The red LED is an indicator of GNSS positioning status. In continuous power mode, it flashes once per second when position is fixed. Otherwise it is off. The timing in detail is as below.

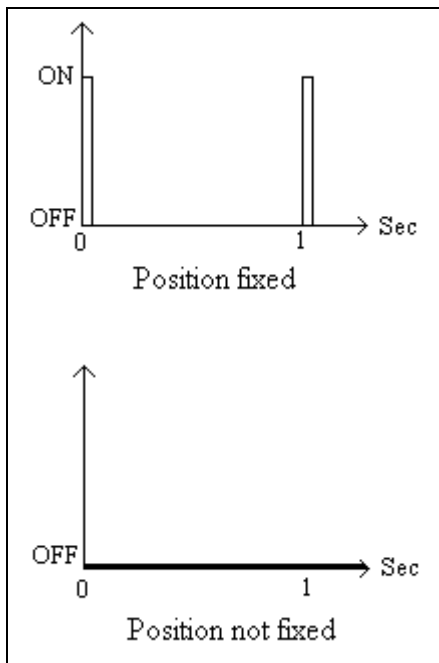

## 6 Pin assignment and descriptions

### ● LS23092-G2

Pin #	Name	Type	Description
1	GND	P	Ground
2	VDD	P	Power input
3	1PPS Output	O	1PPS output ,100ms pulse/sec
4	RX	I	Data input (RS232 level)
5	TX	O	Data output (RS232 level)
6	NC		Not connect

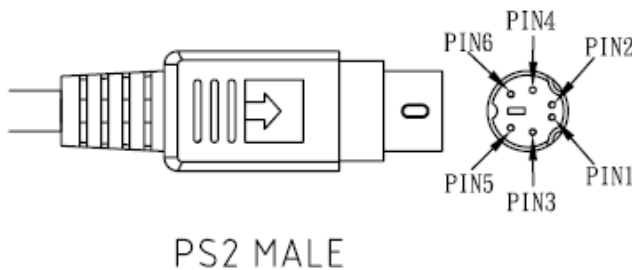

### ● LS23093-G2

Pin #	Name	Type	Description
1	VDD	P	Power input
2	RX	I	Data input (RS232 level)
3	TX	O	Data output (RS232 level)
4	GND	P	Ground
5	1PPS Output	O	1PPS output ,100ms pulse/sec
6	NC		Not connect

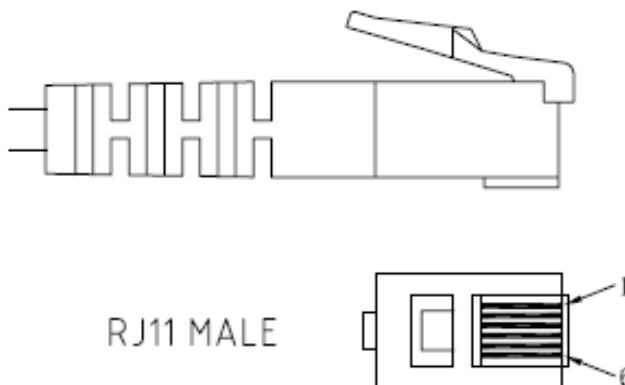

● **LS23095-G2**

Pin #	Name	Type	Description
1	VDD	P	Power input
2	GND	P	Ground
3	1PPS Output	O	1PPS output ,100ms pulse/sec
4	TX	O	Data output (RS232 level)
5	RX	I	Data input (RS232 level)
6	NC		Not connect

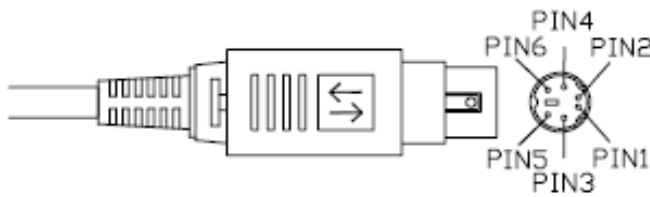

PS2 MALE  
with lock

● **LS23096-G2**

Pin #	Name	Type	Description
1	1PPS Output	O	1PPS output ,100ms pulse/sec
2	GND	P	Ground
3	RX	I	Data input (RS232 level)
4	TX	O	Data output (RS232 level)
5	VDD	P	Power input
6	NC		Not connect

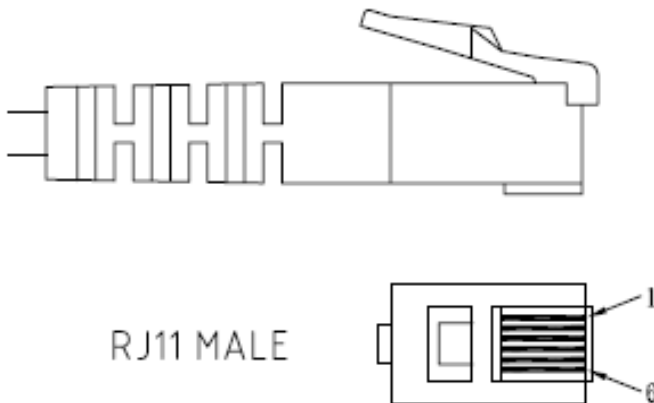

RJ11 MALE

7 DC & Temperature characteristics

7.1 Power consumption (continuous mode)

Parameter	Symbol	Product	Min.	Typ.	Max.	Units
Input voltage	VCC	LS23092-G2	4	5	6	V
		LS23093-G2				
		LS23095-G2				
		LS23096-G2				
Input current	Icc	LS23092-G2		56 <sup>(1)</sup>		mA
		LS23093-G2				
		LS23095-G2				
		LS23096-G2				

1. Measured when position fix (1Hz) is available.

7.2 Temperature characteristics

Parameter	Symbol	Min.	Typ.	Max.	Units
Operating Temperature	Topr	-40	-	85	°C
Storage Temperature	Tstg	-40	-	85	°C

## 8 Mechanical specification

- **LS23092-G2 (RS232 interface)**

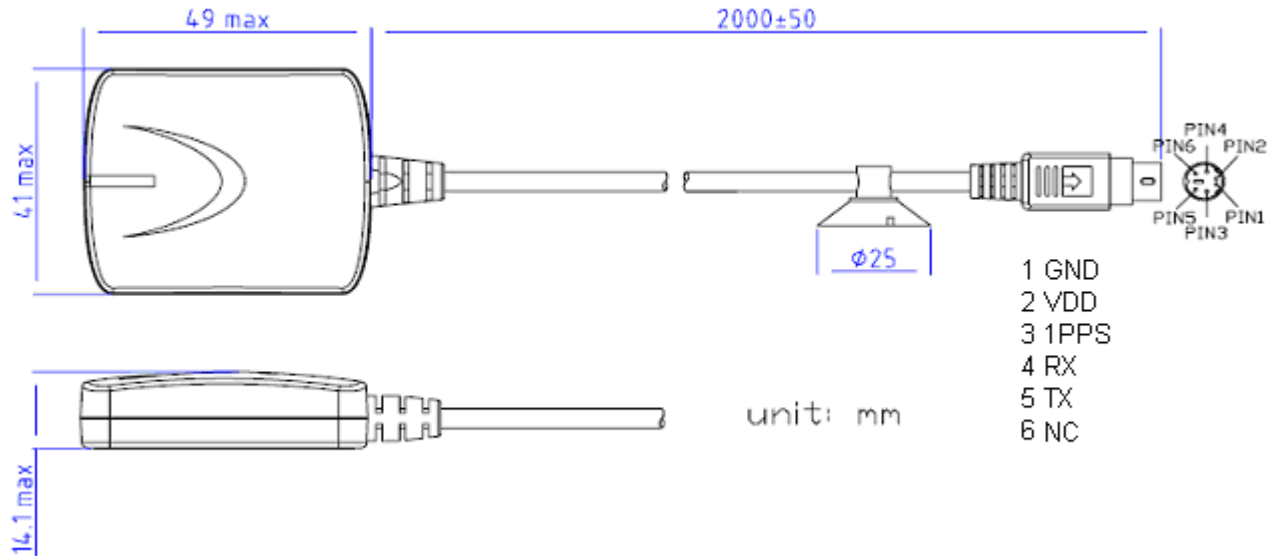

- **LS23093-G2 (RS232 interface)**

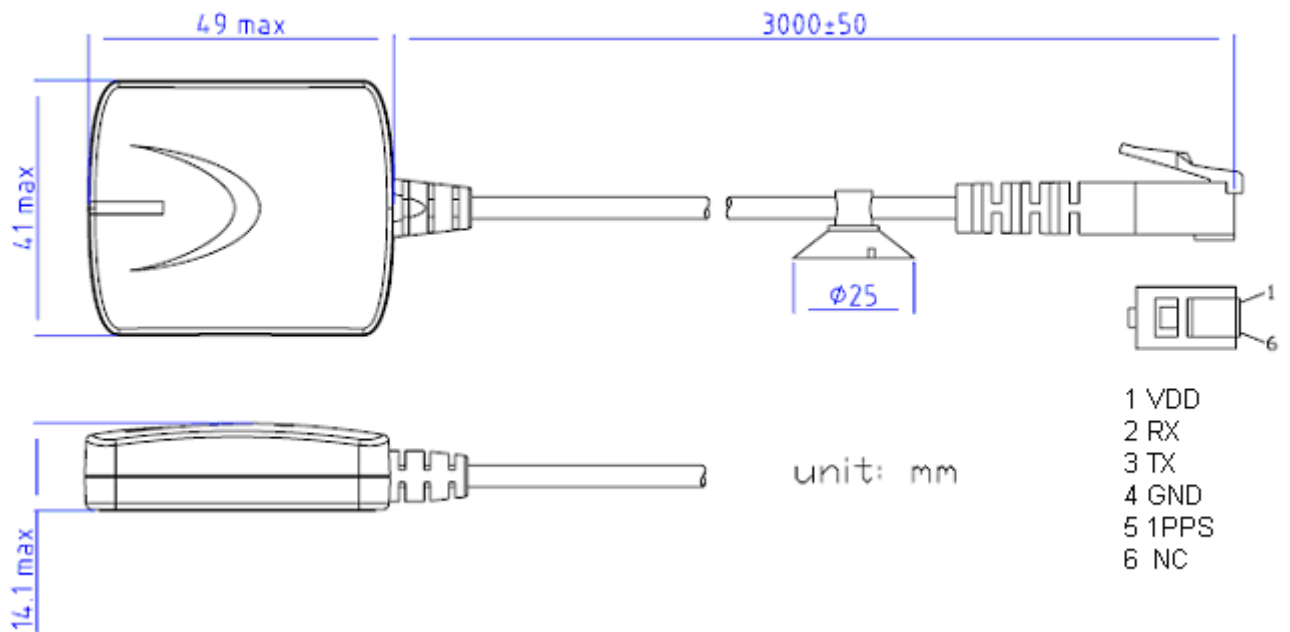

### ● LS23095-G2 (RS232 interface)

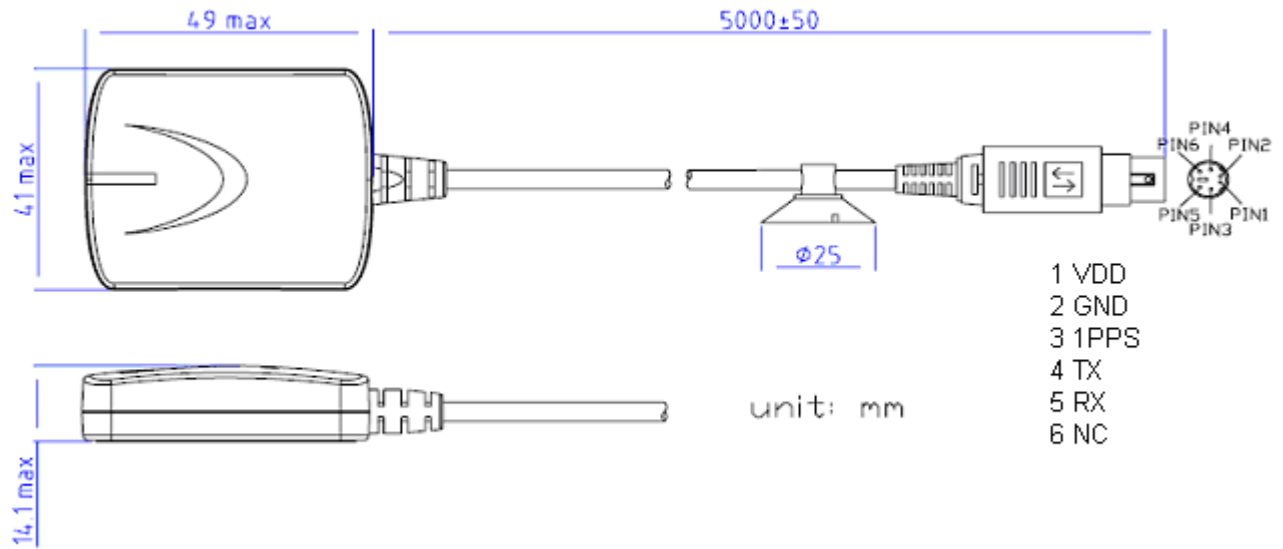

### ● LS23096-G2 (RS232 interface)

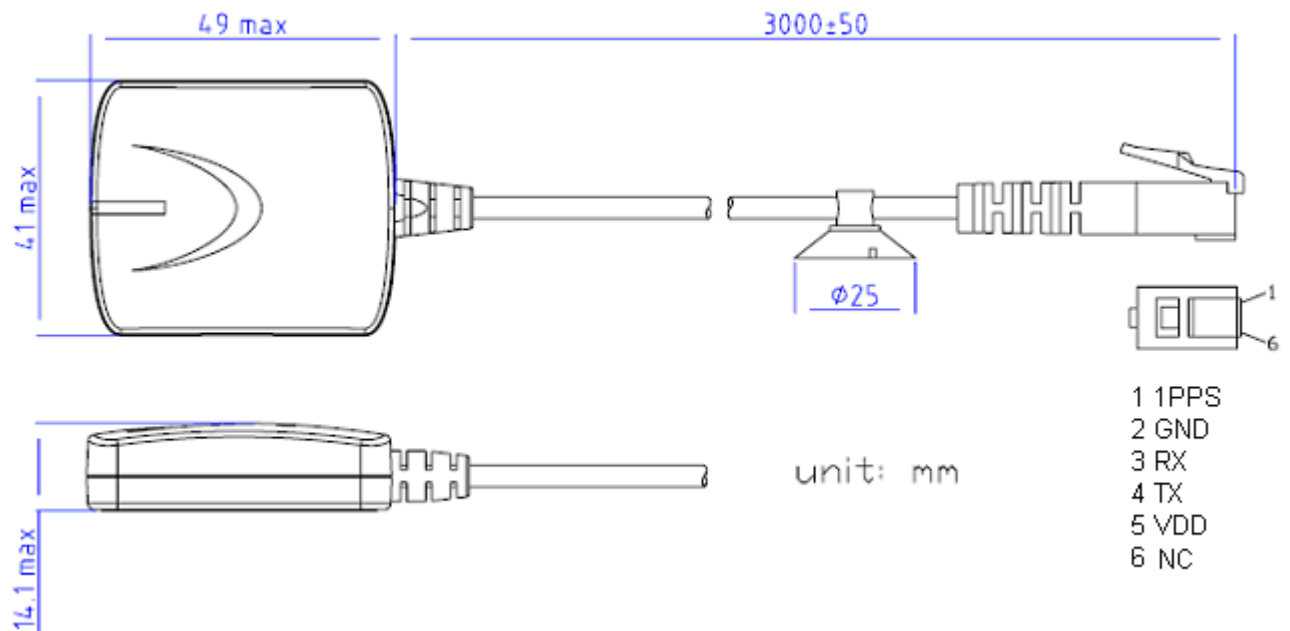

## 9 Software interface

### 9.1 NMEA output message

Table 9.1-1 NMEA output message

NMEA record	Description
GGA	Global positioning system fixed data
GLL	Geographic position - latitude/longitude
GSA	GNSS DOP and active satellites
GSV	GNSS satellites in view
RMC	Recommended minimum specific GNSS data
VTG	Course over ground and ground speed

#### ● GGA--- Global Positioning System Fixed Data

Table 9.1-2 contains the values for the following example:

\$GPGGA,021754.000,2503.71314,N,12138.74545,E,2,19,0.5,120.50,M,15.3,M,,\*6C

Table 9.1- 2 GGA Data Format

Name	Example	Units	Description
Message ID	\$GPGGA		GGA protocol header
UTC Time	021754.000		hhmmss.sss
Latitude	2503.71314		ddmm.mmmm
N/S indicator	N		N=north or S=south
Longitude	12138.74545		dddmm.mmmm
E/W Indicator	E		E=east or W=west
Position Fix Indicator	2		See Table 9.1-3
Satellites Used	19		Range 0 to 12
HDOP	0.5		Horizontal Dilution of Precision
MSL Altitude	120.50	meters	
Units	M	meters	
Geoid Separation	15.3	meters	
Units	M	meters	
Age of Diff. Corr.		second	Null fields when DGPS is not used
Diff. Ref. Station ID			
Checksum	*6C		
<CR> <LF>			End of message termination

Table 9.1-3 Position Fix Indicators

Value	Description
0	Fix not available or invalid



1	GPS SPS Mode, fix valid
2	Differential GPS, SPS Mode, fix valid
3-5	Not supported
6	Dead Reckoning Mode, fix valid

● **GLL--- Geographic Position – Latitude/Longitude**

Table 9.1-4 contains the values for the following example:

\$GPGLL,2503.71314,N,12138.74545,E,021754.000,A,D\*53

Table 9.1-4 GLL Data Format

Name	Example	Units	Description
Message ID	\$GPGLL		GLL protocol header
Latitude	2503.71314		ddmm.mmmm
N/S indicator	N		N=north or S=south
Longitude	12138.74545		dddmm.mmmm
E/W indicator	E		E=east or W=west
UTC Time	021754.000		hhmmss.sss
Status	A		A=data valid or V=data not valid
Mode	D		A=autonomous, D=DGPS, E=DR, N=Data not valid, R=Coarse Position, S=Simulator
Checksum	*53		
<CR> <LF>			End of message termination

● **GSA---GNSS DOP and Active Satellites**

Table 9.1-5 contains the values for the following example:

\$GNGSA,A,3,20,06,16,31,29,23,32,14,21,30,03,,1.1,0.5,1.0\*24

\$GNGSA,A,3,73,80,74,70,71,82,72,,,,,1.1,0.5,1.0\*29

\$GNGSA,A,3,193,,,,,,1.1,0.5,1.0\*13

Table 9.1-5 GSA Data Format

Name	Example	Units	Description
Message ID	\$GNGSA		GSA protocol header
Mode 1	A		See Table 9.1-6
Mode 2	3		See Table 9.1-7
ID of satellite used	20		Sv on Channel 1
ID of satellite used	06		Sv on Channel 2
....			....
ID of satellite used			Sv on Channel 12
PDOP	1.1		Position Dilution of Precision
HDOP	0.5		Horizontal Dilution of Precision

VDOP	1.0		Vertical Dilution of Precision
Checksum	*24		
<CR> <LF>			End of message termination

Table 9.1-6 Mode 1

Value	Description
M	Manual- forced to operate in 2D or 3D mode
A	Automatic-allowed to automatically switch 2D/3D

Table 9.1-7 Mode 2

Value	Description
1	Fix not available
2	2D
3	3D

### ● GSV---GNSS Satellites in View

Table 9.1-8 contains the values for the following example:

```
$GNGSV,5,1,20,03,33,200,40,06,47,184,44,14,25,148,40,16,56,284,42*6B
$GNGSV,5,2,20,20,14,275,36,21,06,097,36,23,20,320,41,29,10,039,38*62
$GNGSV,5,3,20,30,60,344,46,31,48,054,47,32,26,250,36,74,26,325,45*6E
$GNGSV,5,4,20,82,09,029,37,73,38,025,46,70,07,191,40,80,13,075,43*60
$GNGSV,5,5,20,71,31,238,37,72,24,298,36,50,50,134,37,193,00,000,37*54
```

Table 9.1-8 GSV Data Format

Name	Example	Units	Description
Message ID	\$GNGSV		GSV protocol header
Total number of messages <sup>1</sup>	5		Range 1 to 8
Message number <sup>1</sup>	1		Range 1 to 8
Satellites in view	20		
Satellite ID	03		Channel 1 (Range 01 to 196)
Elevation	33	degrees	Channel 1 (Range 00 to 90)
Azimuth	200	degrees	Channel 1 (Range 000 to 359)
SNR (C/No)	40	dB-Hz	Channel 1 (Range 00 to 99, null when not tracking)
Satellite ID	06		Channel 4 (Range 01 to 32)
Elevation	47	degrees	Channel 4 (Range 00 to 90)
Azimuth	184	degrees	Channel 4 (Range 000 to 359)
SNR (C/No)	44	dB-Hz	Channel 4 (Range 00 to 99, null when not tracking)
Checksum	*6B		
<CR> <LF>			End of message termination

1. Depending on the number of satellites tracked multiple messages of GSV data may be required.

● **RMC---Recommended Minimum Specific GNSS Data**

Table 9.1-9 contains the values for the following example:

\$GPRMC,021754.000,A,2503.71314,N,12138.74545,E,0.0,0.0,300712,,D\*63

Table 9.1-9 RMC Data Format

Name	Example	Units	Description
Message ID	\$GPRMC		RMC protocol header
UTC Time	021754.000		hhmmss.sss
Status	A		A=data valid or V=data not valid
Latitude	2503.71314		ddmm.mmmm
N/S Indicator	N		N=north or S=south
Longitude	12138.74545		dddmm.mmmm
E/W Indicator	E		E=east or W=west
Speed over ground	0.0	knots	True
Course over ground	0.0	degrees	
Date	300712		ddmmyy
Magnetic variation		degrees	
Variation sense			E=east or W=west (Not shown)
Mode	D		A=autonomous, D=DGPS, E=DR, N=Data not valid, R=Coarse Position, S=Simulator
Checksum	*63		
<CR> <LF>			End of message termination

● **VTG---Course Over Ground and Ground Speed**

Table 9.1-10 contains the values for the following example:

\$GPVTG,0.0,T,,M,0.0,N,0.0,K,D\*08

Table 9.1-10 VTG Data Format

Name	Example	Units	Description
Message ID	\$GPVTG		VTG protocol header
Course over ground	0.0	degrees	Measured heading
Reference	T		True
Course over ground		degrees	Measured heading
Reference	M		Magnetic
Speed over ground	0.0	knots	Measured speed
Units	N		Knots
Speed over ground	0.0	km/hr	Measured speed
Units	K		Kilometer per hour
Mode	D		A=autonomous, D=DGPS, E=DR, N=Data not valid,

			R=Coarse Position, S=Simulator
Checksum	*08		
<CR> <LF>			End of message termination

## 9.2 Proprietary NMEA input/output message

The table below summarizes the set of proprietary commands for the ST-1612-G

Command	Description
\$PSTMCOLD, F<CR><LF>	Perform a COLD start with all data cleared.
\$PSTMWARM<CR><LF>	Perform a WARM start.
\$PSTMHOT<CR><LF>	Perform a HOT start.
\$PSTMSBASONOFF<CR><LF>	Toggle the SBAS feature ON and OFF
\$PSTMSETPAR,1200,Value <sup>1</sup> <CR><LF>	System Configuration Commands
\$PSTMSAVEPAR<CR><LF>	Save current configuration data block into the backup memory.
\$PSTMSRR<CR><LF>	Executes a system reset. The GNSS firmware is rebooted.
\$PSTMGPSRESET<CR><LF>	Reset the GPS receiver engine <sup>2</sup>
\$PSTMGETPAR,1500<CR><LF>	Get firmware version

Note 1:

Value	GPS	GLONASS	Drive	Walk
0x19FF965C	O	O	O	
0x19FF565C	O	O		O
0x19DD965C	O		O	
0x19DD565C	O			O
0x19BE965C		O	O	
0x19BE565C		O		O

2: using this command the GPS module won't reboot.

10 Packing information

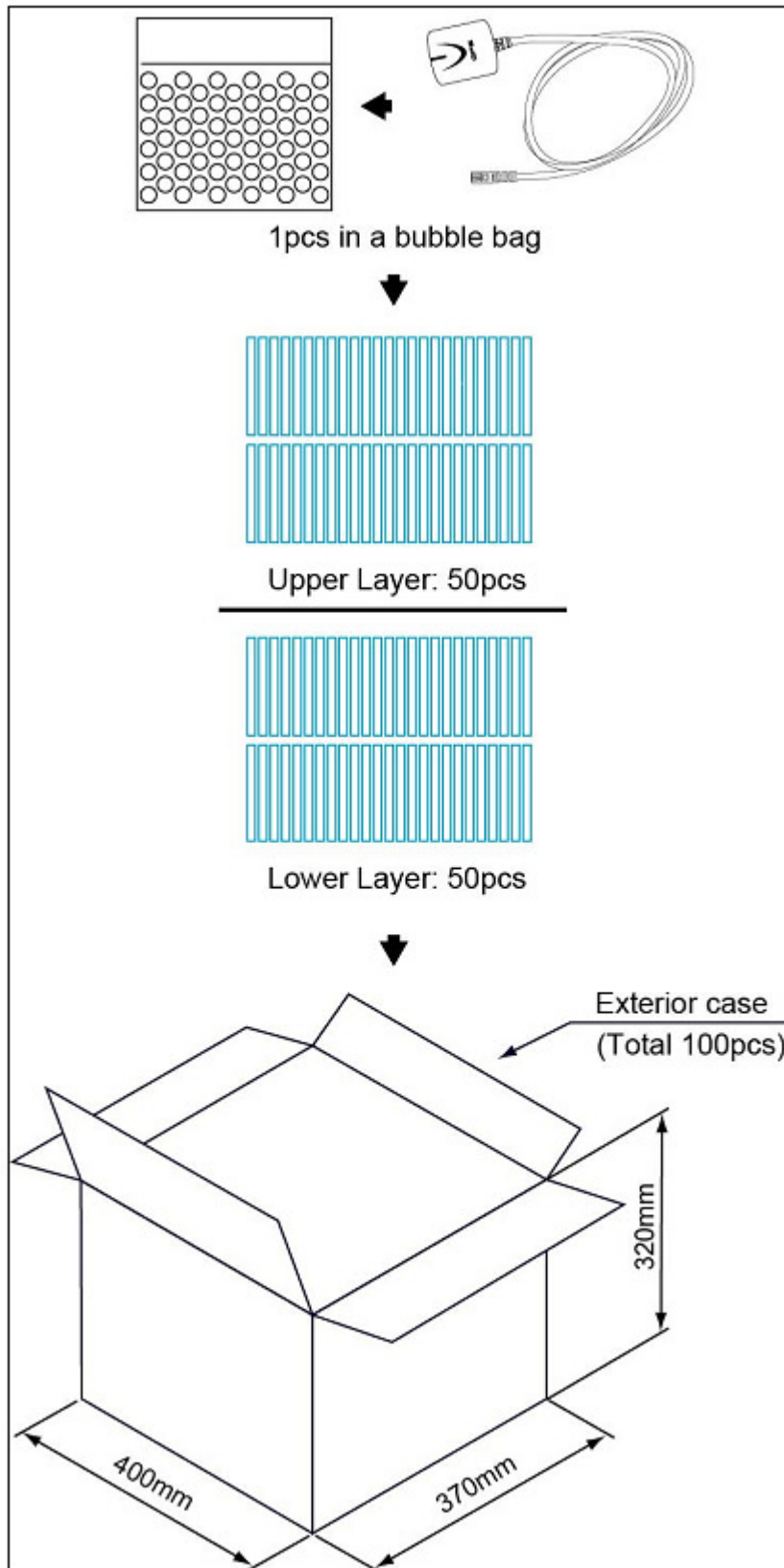

## Document change list

### Revision 1.0

- First release on March 10, 2015.