

Product name	Description	Version
HD-1010	Datasheet of HD-1010 standalone GPS module	1.0

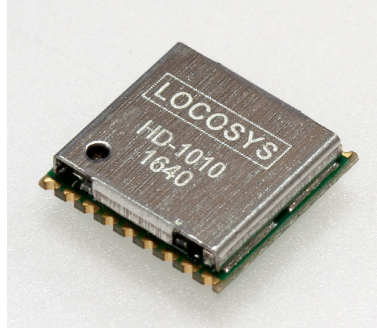

1 Introduction

LOCOSYS HD-1010 is a complete standalone GPS module which use CEC HED latest GPS chip to integrate an additional LNA and SAW filter. The module can simultaneously acquire and track multiple satellite constellations that include GPS, QZSS and Galileo. It features low power and small form factor. Besides, it can provide you with superior sensitivity and performance even in urban canyon and dense foliage environment.

LOCOSYS HD-1010 module is compatible with world-class mainstream GPS module in size and UART interface, the SMD connection type design makes it easy for users' mass production and also save users' design engineer efforts and production costs.

2 Features

- HED high sensitivity solution
- Support GPS, QZSS, and Galileo (in future)
- Capable of SBAS (WAAS, EGNOS, MSAS, GAGAN)
- Support up to 72-channel
- Fast TTFF at low signal level
- Support 1PPS output
- Built-in DC/DC converter to save power
- Built-in an additional LNA and SAW filter.
- Embedded active antenna supervisor
- Small form factor 10.1 x 9.7 x 2.2 mm
- Industrial grade operating temperature
- SMD type; RoHS compliant
- ISO/TS 16949 quality control

3 Application

- Personal/Vehicle positioning, navigation and tracking system
- Wearable and handheld device
- UAV/FPV/Drone application
- Digital camera or portable game machine
- Driving recorder

4 Overview

4.1 Block Diagram

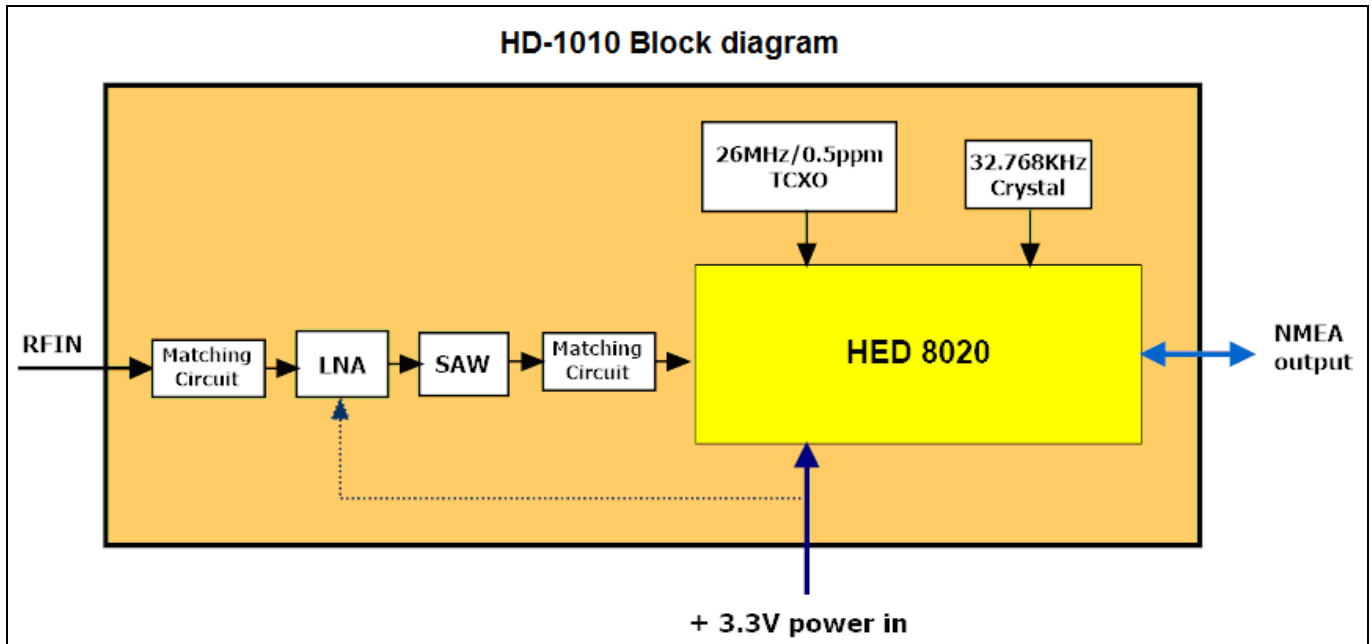

4.2 GPS Performance

Chip	HD8020	
Frequency	GPS, GALILEO, QZSS: L1 1575.42MHz, C/A code	
Channels	Up to 72 channels	
Update rate	1Hz	
Sensitivity	Tracking	-160dBm up to -161dBm (with external LNA)
	Cold start	-146.5dBm up to -148dBm (with external LNA)
Acquisition Time	Hot start (Open Sky)	< 1s (typical)
	Cold Start (Open Sky)	28s (typical)
Position Accuracy	Autonomous	2.5m CEP
Max. Altitude	< 18,000 m	
Max. Velocity	< 515 m/s	
Protocol Support	NMEA 0183 ver. 3.01	9600bps, 8 data bits, no parity, 1 stop bits (default)
		1Hz: GGA, GLL, GSA, GSV, RMC, and VTG

4.3 Passive antenna application circuit diagram

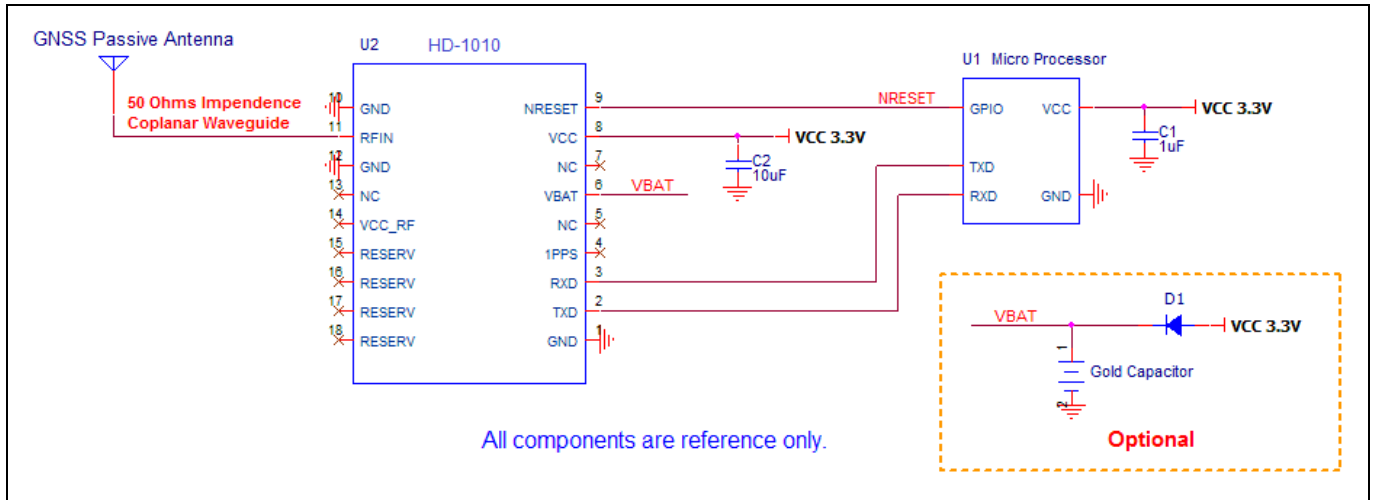

4.4 Active antenna supervisor circuit diagram

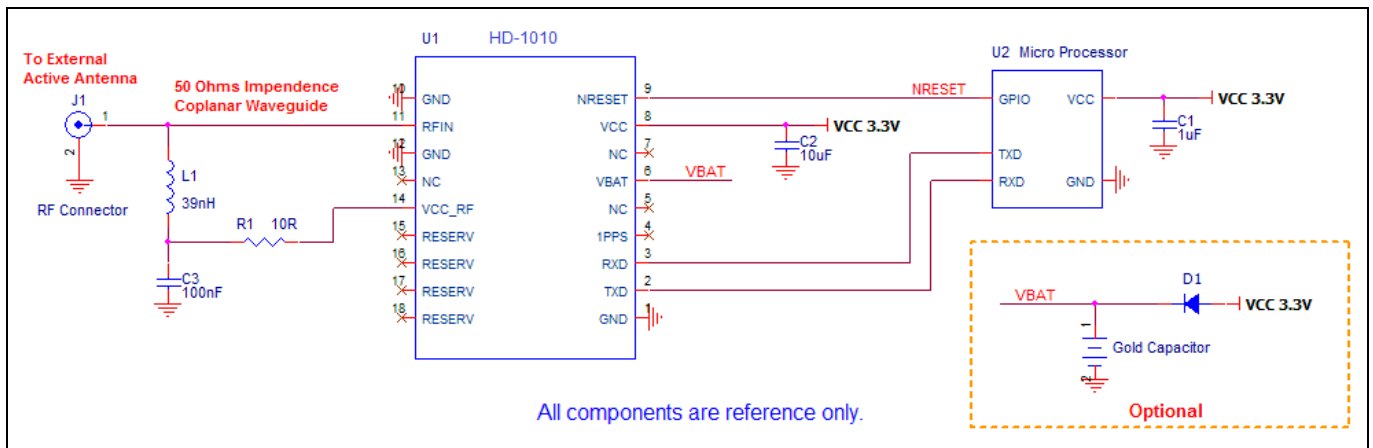

Table 4-1 Antenna status in NMEA sentence

Active antenna status	Output message per second from GPS module
Antenna is short.	\$GNTXT,01,01,01,ANT_SHORT*06
Antenna is well connected.	\$GNTXT,01,01,01,ANT_OK*50
Antenna is open, i.e. not connected.	\$GNTXT,01,01,01,ANT_OPEN*40

4.5 Pin assignment and descriptions (Top View)

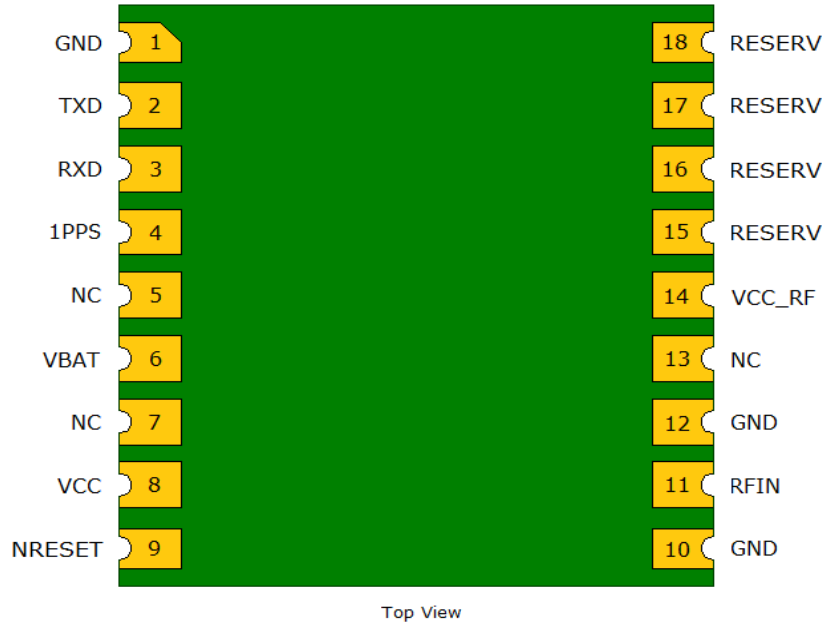

Table 4-2 Pin descriptions

Pin #	Name	Type	Description	Note
1	GND	P	Ground	
2	TXD	O	UART, asynchronous output.	
3	RXD	I	UART, asynchronous input.	
4	1PPS	O	Time pulse (1PPS, default 100 ms pulse/sec when 3D fix is available)	
5	NC		No connect	
6	VBAT	P	Backup battery supply voltage, this pin is optional.	
7	NC		No connect	
8	VCC	P	DC supply voltage	
9	NRESET	I	Reset input, active low; keep open if unused.	
10	GND	P	Ground	
11	RFIN		GPS matched RF input, DC block inside.	1
12	GND	P	Ground	
13	NC		No connect	
14	VCC_RF	P	Used for active antenna or external LNA supply.	
15	RESERV		Reserved, keep open.	
16	RESERV		Reserved, keep open.	
17	RESERV		Reserved, keep open.	
18	RESERV		Manufacture used, keep open.	

Note:

1. Coplanar waveguide is recommended.

5 DC & Temperature characteristics

5.1 Absolute maximum ratings

Parameter	Symbol	Ratings	Units
DC Supply Voltage	VCC	3.6	V
Input Backup Battery Voltage	VBAT	3.6	V
Operating Temperature Range	Topr	-40 ~ 85	°C
Storage Temperature Range	Tstg	-40 ~ 85	°C

5.2 DC Electrical characteristics

Parameter	Symbol	Conditions	Min.	Typ.	Max.	Units
Input Voltage	VCC		3.0	3.3	3.6	V
Input Backup Battery Voltage	VBAT		1.6		3.6	V
VCC_RF Output Voltage	VCC_RF			0.95*VCC		V
Supply Current	Iss	VCC = 3.3V, w/o active antenna, Peak Acquisition Tracking			136	mA
					54	mA
					31	mA
Backup Battery Current	Ibat	Remove the power of VCC		13		uA
VCC_RF Output Current	I _{out}	VIN = 3.3V			40	mA
High Level Input Voltage	V _{IH}		0.67*VCC		VCC	V
Low Level Input Voltage	V _{IL}		0		0.9	V
High Level Output Voltage	V _{OH}		0.67*VCC		VCC	V
Low Level Output Voltage	V _{OL}				0.4	V
High Level Output Current	I _{OH}			2		mA
Low Level Output Current	I _{OL}			2		mA

5.3 Temperature characteristics

Parameter	Symbol	Min.	Typ.	Max.	Units
Operating Temperature	Topr	-40	-	85	°C
Storage Temperature	Tstg	-40	25	85	°C

6 Mechanical specification

6.1 Outline dimensions

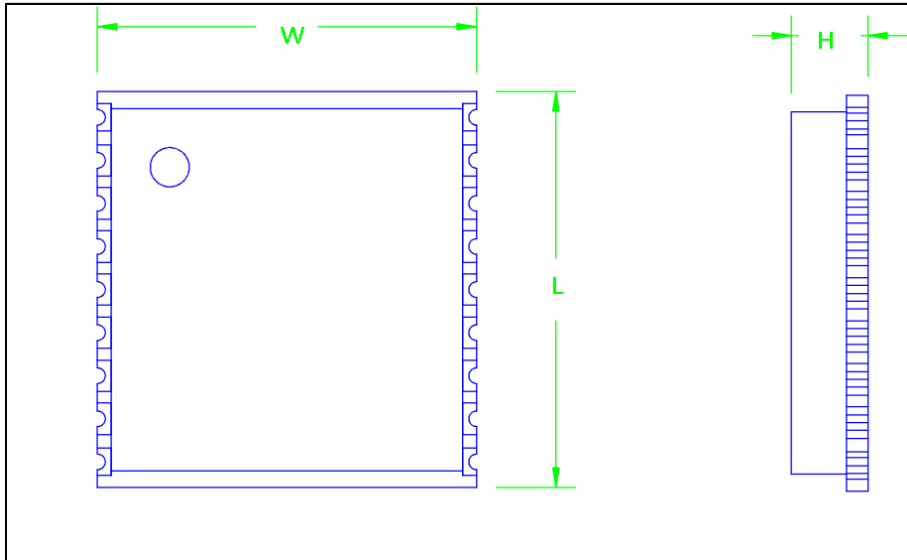

Symbol	Min. (mm)	Typ. (mm)	Max. (mm)
W	9.6	9.74	9.8
L	9.85	10.18	10.35
H	1.85	2.03	2.15

6.2 Recommended land pattern dimensions

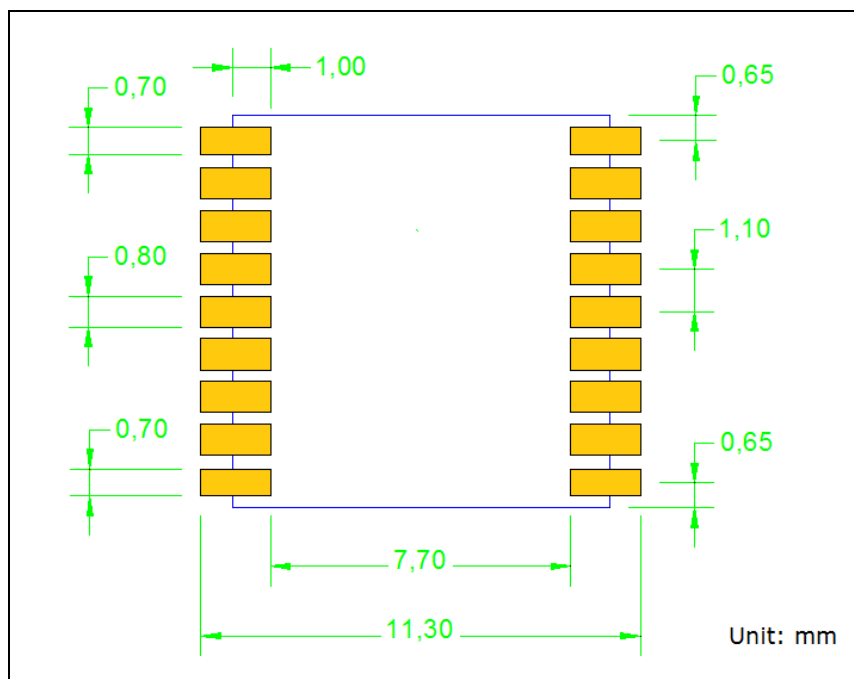

Note: The recommended land pattern dimensions are shown for reference only, as actual pad layouts may vary depending on application.

7 Software interface

7.1 NMEA output message

Table 7.1-1 NMEA output message

NMEA	Description
GGA	Global positioning system fixed data
GLL	Geographic position - latitude/longitude
GSA	GPS DOP and active satellites
GSV	GPS satellites in view
RMC	Recommended minimum specific GPS data
VTG	Course over ground and ground speed

- **GGA Global positioning system fixed data**

Table 7.1-2 contains the values for the following example:

\$GPGGA,053740.000,2503.6319,N,12136.0099,E,1,08,1.1,63.8,M,15.2,M,, *64

Table 7.1-2 GGA Data Format

Name	Example	Units	Description
Message ID	\$GPGGA		GGA protocol header
UTC Time	053740.000		hhmmss.sss
Latitude	2503.6319		ddmm.mmmm
N/S indicator	N		N=north or S=south
Longitude	12136.0099		dddmm.mmmm
E/W Indicator	E		E=east or W=west
Position Fix Indicator	1		See Table 7.1-3
Satellites Used	08		Range 0 to 12
HDOP	1.1		Horizontal Dilution of Precision
MSL Altitude	63.8	meters	
Units	M	meters	
Geoidal Separation	15.2	meters	
Units	M	meters	
Age of diff. GPS data		second	Null fields when DGPS is not used
Diff. Ref. Station ID			
Checksum	*64		
<CR> <LF>			End of message termination

Table 7.1-3 Position Fix Indicators

Value	Description
0	Fix not available or invalid
1	GPS SPS Mode, fix valid

2	Differential GPS, SPS Mode, fix valid
3-5	Not supported
6	Dead Reckoning Mode, fix valid

- **GLL--- Geographic Position – Latitude/Longitude**

Table 7.1-4 contains the values for the following example:

\$GPGLL,2503.6319,N,12136.0099,E,053740.000,A,A*52

Table 7.1-4 GLL Data Format

Name	Example	Units	Description
Message ID	\$GPGLL		GLL protocol header
Latitude	2503.6319		ddmm.mmmm
N/S indicator	N		N=north or S=south
Longitude	12136.0099		dddmm.mmmm
E/W indicator	E		E=east or W=west
UTC Time	053740.000		hhmmss.sss
Status	A		A=data valid or V=data not valid
Mode	A		A=autonomous, D=DGPS, N=Invalid
Checksum	*52		
<CR> <LF>			End of message termination

- **GSA--GPS DOP and Active Satellites**

Table 7.1-5 contains the values for the following example:

\$GPGSA,A,3,24,07,17,11,28,08,20,04,,,,,2.0,1.1,1.7*35

Table 7.1-5GSA Data Format

Name	Example	Units	Description
Message ID	\$GPGSA		GSA protocol header
Mode 1	A		See Table 7.1-6
Mode 2	3		See Table 7.1-7
ID of satellite used	24		Sv on Channel 1
ID of satellite used	07		Sv on Channel 2
....		
ID of satellite used			Sv on Channel 12
PDOP	2.0		Position Dilution of Precision
HDOP	1.1		Horizontal Dilution of Precision
VDOP	1.7		Vertical Dilution of Precision
Checksum	*35		
<CR> <LF>			End of message termination

Table 7.1-6 Mode 1

Value	Description
M	Manual- forced to operate in 2D or 3D mode
A	Automatic-allowed to automatically switch 2D/3D

Table 7.1-7 Mode 2

Value	Description
1	Fix not available
2	2D ⁽¹⁾
3	3D

Note 1: 2D fix hint that the receiver position error meets the 2D level. Maybe under this condition the used satellite number is little more than 4

- **GSV---GPS Satellites in View**

Table 7.1-8 contains the values for the following example:

```
$GPGSV,3,1,12,28,81,285,42,24,67,302,46,31,54,354,,20,51,077,46*73
$GPGSV,3,2,12,17,41,328,45,07,32,315,45,04,31,250,40,11,25,046,41*75
$GPGSV,3,3,12,08,22,214,38,27,08,190,16,19,05,092,33,23,04,127,*7B
```

Table 7.1-8 GSV Data Format

Name	Example	Units	Description
Message ID	\$GPGSV		GSV protocol header
Total number of messages ¹	3		Range 1 to 3
Message number ¹	1		Range 1 to 3
Satellites in view	12		
Satellite ID ²	28		Channel 1 (Range 01 to 196)
Elevation	81	degrees	Channel 1 (Range 00 to 90)
Azimuth	285	degrees	Channel 1 (Range 000 to 359)
SNR (C/No)	42	dB-Hz	Channel 1 (Range 00 to 99, null when not tracking)
....		
Satellite ID	20		Channel 4 (Range 01 to 196)
Elevation	51	degrees	Channel 4 (Range 00 to 90)
Azimuth	077	degrees	Channel 4 (Range 000 to 359)
SNR (C/No)	46	dB-Hz	Channel 4 (Range 00 to 99, null when not tracking)
Checksum	*73		
<CR> <LF>			End of message termination

Note 1: Depending on the number of satellites tracked multiple messages of GSV data may be required.

- **RMC---Recommended Minimum Specific GPS Data**

Table 7.1-9 contains the values for the following example:

\$GPRMC,053740.000,A,2503.6319,N,12136.0099,E,2.69,79.65,100106,,,A*53

Table 7.1-9 RMC Data Format

Name	Example	Units	Description
Message ID	\$GPRMC		RMC protocol header
UTC Time	053740.000		hhmmss.sss
Status	A		A=data valid or V=data not valid
Latitude	2503.6319		ddmm.mmmm
N/S Indicator	N		N=north or S=south
Longitude	12136.0099		dddmm.mmmm
E/W Indicator	E		E=east or W=west
Speed over ground	2.69	knots	True
Course over ground	79.65	degrees	
Date	100106		ddmmyy
Magnetic variation		degrees	(Not shown)
Variation sense			E=east or W=west (Not shown)
Mode	A		A=Autonomous, D=DGPS, N= Invalid
Checksum	*53		
<CR> <LF>			End of message termination

- **VTG---Course Over Ground and Ground Speed**

Table 7.1-10 contains the values for the following example:

\$GPVTG,79.65,T,,M,2.69,N,5.0,K,A*38

Table 7.1-10 VTG Data Format

Name	Example	Units	Description
Message ID	\$GPVTG		VTG protocol header
Course over ground	79.65	degrees	Measured heading
Reference	T		True
Course over ground		degrees	Measured heading
Reference	M		Magnetic
Speed over ground	2.69	knots	Measured speed
Units	N		Knots
Speed over ground	5.0	km/hr	Measured speed
Units	K		Kilometer per hour
Mode	A		A=Autonomous, D=DGPS, N=Invalid
Checksum	*38		
<CR> <LF>			End of message termination

7.2 HED Proprietary Binary Packet Set

Table 7.2-1 The table below summarizes the set of proprietary commands for the HD-1010

Command descriptions	Software command
Perform a Cold start	F1 D9 06 40 01 00 01 48 22
Perform a Warm start	F1 D9 06 40 01 00 02 49 23
Perform a Hot start	F1 D9 06 40 01 00 03 4A 24
Perform a Factory reset :	F1 D9 06 09 08 00 02 00 00 00 FF FF FF FF 15 01
UART configures as 115200bps	F1 D9 06 00 08 00 00 00 00 00 C2 01 00 D1 E0
UART configures as 9600bps	F1 D9 06 00 08 00 00 00 00 80 25 00 00 B3 07
Switch to Vehicle mode	F1 D9 06 0F 02 00 96 00 AD A3
Switch to Pedestrian mode	F1 D9 06 0F 02 00 00 00 17 77
Query firmware version ¹	F1 D9 0A 05 00 00 0F 37

Note

1: Firmware version will show as Hex mode too.

2: Add **0D 0A** at the end of command.

8 Recommended soldering reflow profile

The module belongs to RoHS device. The maximum of reflow temperature, real on top of PCB, is not over 240 Celsius.

Lead-free Processes

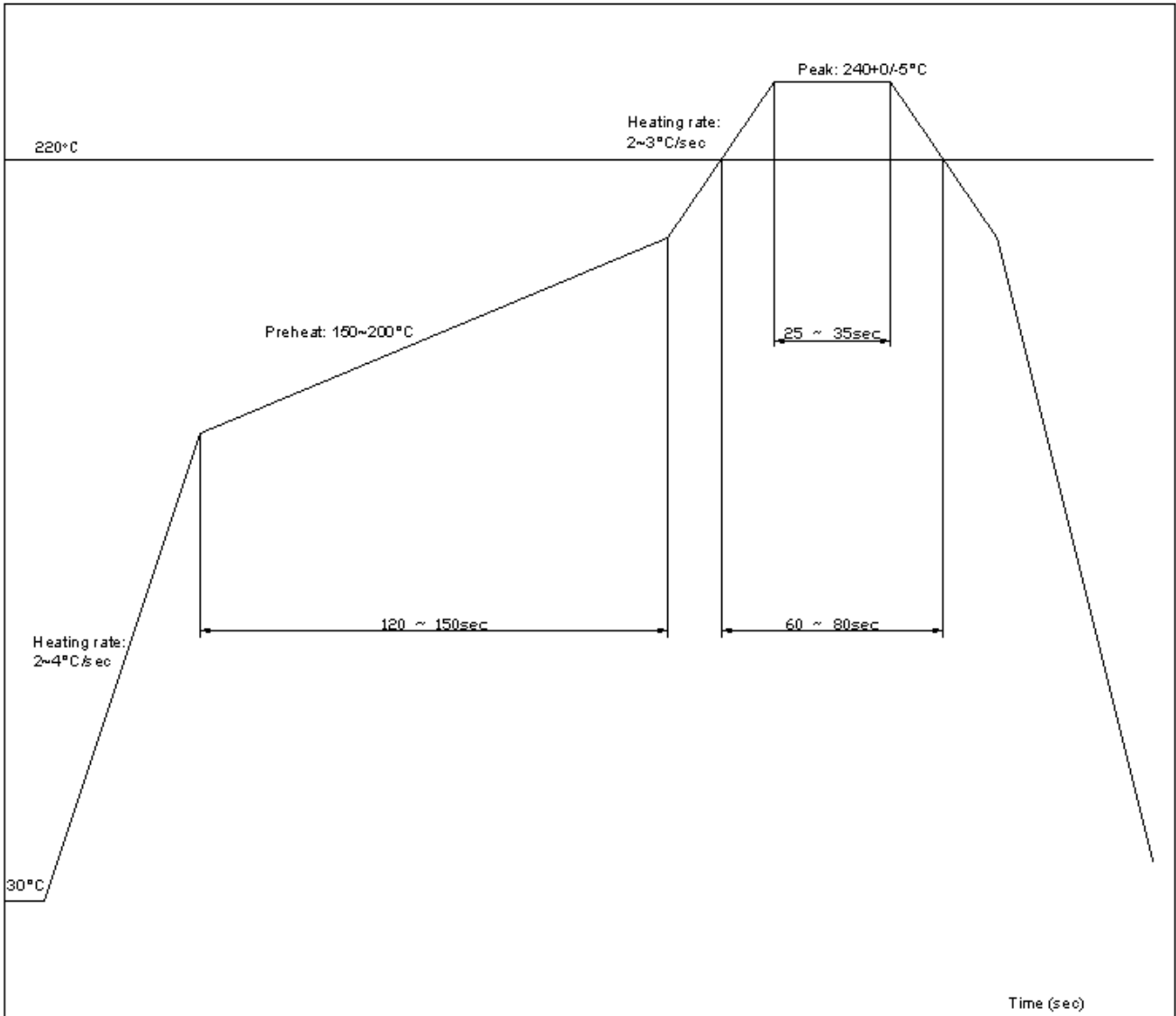

Lead-Free Solder Paste (Sn 96.5-Ag 3.0-Cu 0.5)

Cycle Interval: 300 sec

Note:

The HD-1010 module should be soldered on the topside in the soldering process to prevent from falling down.

9 Reel packing information

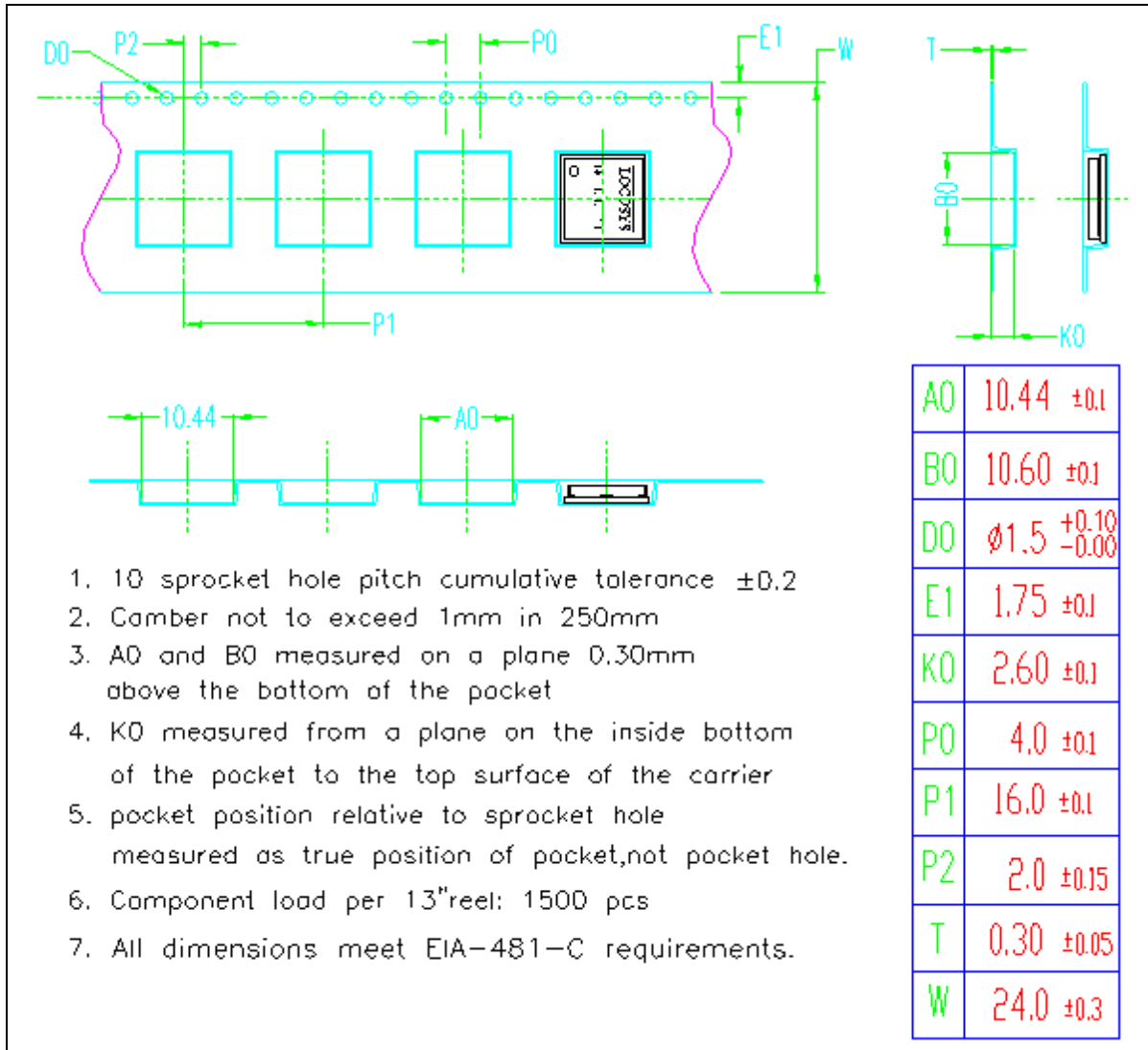

1. 10 sprocket hole pitch cumulative tolerance ±0.2
2. Camber not to exceed 1mm in 250mm
3. A0 and B0 measured on a plane 0.30mm above the bottom of the pocket
4. K0 measured from a plane on the inside bottom of the pocket to the top surface of the carrier
5. pocket position relative to sprocket hole measured as true position of pocket, not pocket hole.
6. Component load per 13" reel: 1500 pcs
7. All dimensions meet EIA-481-C requirements.

10 Packing and Handling

GPS modules, like any other SMD devices, are sensitive to moisture, electrostatic discharge, and temperature. By following the description sketched in the document for LOCOSYS GPS module storage and handling, it is possible to reduce the chances of them being damaged during production.

10.1 Packing

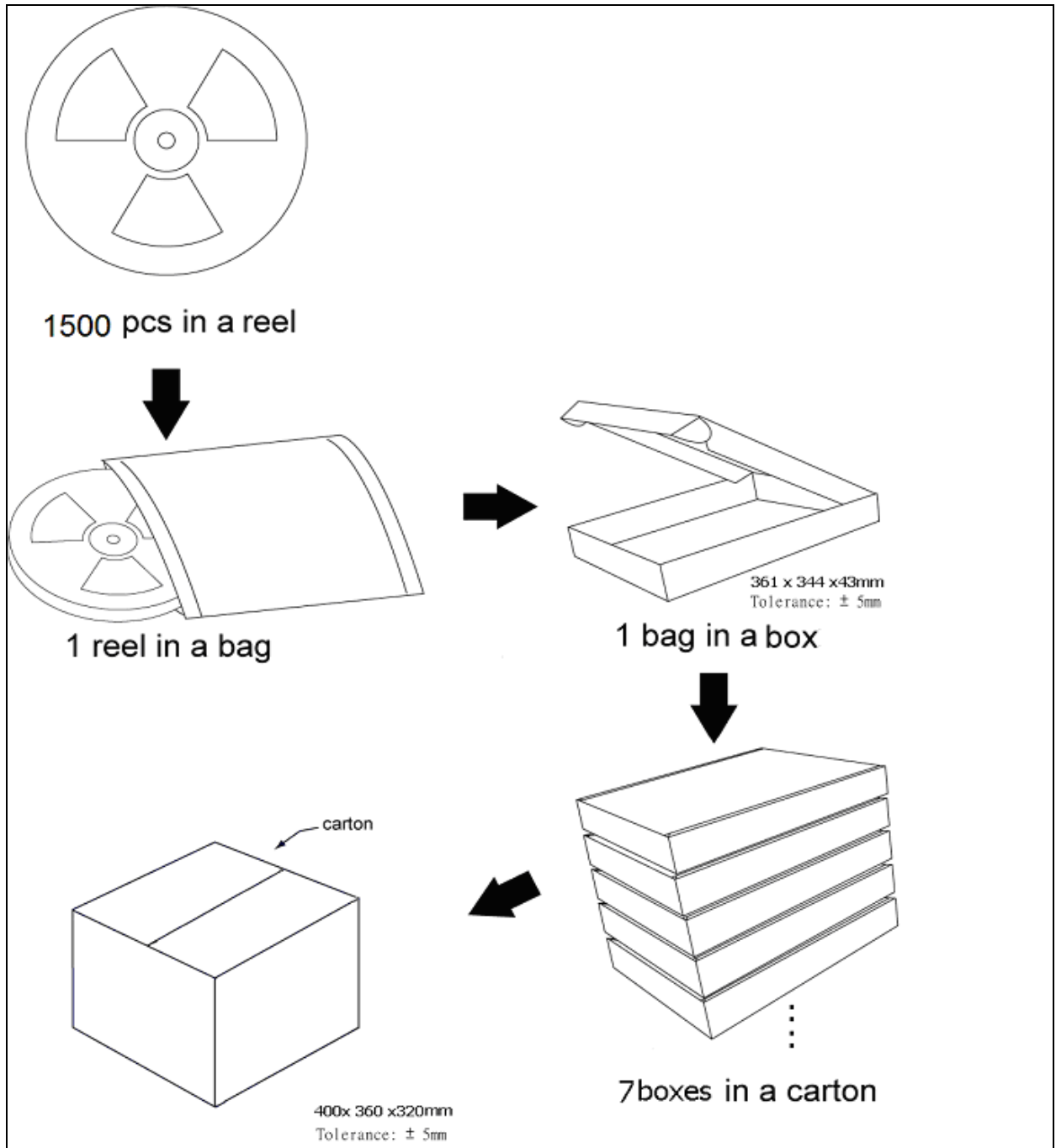

10.2 Moisture Sensitivity

The module belongs to moisture sensitive device (IPC/JEDEC J-STD-020C Level III). If it is not used by then, we strong recommended storing the GPS modules in dry places such as dry cabinet. The approximate shelf life for LOCOSYS GPS modules packages is 6 months from the bag seal date, when store in a non-condensing storage environment (<30°C/60% RH)

10.3 ESD Handling



Please carefully follow the following precautions to prevent severe damage to GPS modules.

LOCOSYS GPS modules are sensitive to electrostatic discharges, and thus are Electrostatic Sensitive Devices (ESD). Careful handling of the GPS modules and in particular RFIN pin must follow the standard ESD safety protections:

- Unless there is a galvanic coupling between the local GND and the PCB GND, then the first point of contact when handling the PCB shall always be between the local GND and PCB GND.
- Before working with RFIN pin, please make sure the GND is connected
- When working with RFIN pin, do not contact any charges capacitors or materials that can easily develop or store charges such as patch antenna, coax cable, soldering iron.
When soldering RFIN pin, please make sure to use an ESD safe soldering iron (tip).

Document change list

Revision 1.0

- First release on October 18, 2016.