

Product name	Description	Version
G310	Datasheet of G310 GNSS integrated with embedded DR	1.0



1 Introduction

The LOCOSYS G310 product is complete standalone Dead Reckoning (DR) smart antenna system, including an embedded antenna, a ST-1612i-DGU module, a 2.4G module (non-standard Profile), and a BLE 4.0 module (GATT Profile), which designed for a broad spectrum of OEM system applications. The LOCOSYS G310 can simultaneously acquire and track multiple satellite constellations that include GPS, GLONASS, GALILEO and QZSS. And through the BLE module, the LOCOSYS G310 can be linked to various mobile phones of brands that support BLE, and can retrieve the relevant GNSS messages. The vehicle speed of G310 is from wireless transmission through a OBD II 2.4G dongle. With adverse GNSS conditions in urban canyons, tunnels, or parking garages where DR boosts the accuracy, and the software fills the gaps. And the LOCOSYS G310 can be linked with Google map for real-time navigation functions.

2 Features

- Support GPS, GLONASS, GALILEO and QZSS
- Capable of SBAS (WAAS, EGNOS, MSAS)
- 48 tracking channels and 2 fast acquisition channels
- Fast TTFF at low signal level
- Multi colors LED for tasks status display

- Built-in Dead Reckoning (DR) software
- Built-in MEMS sensor (3-axis Gyroscope and 3-axis Accelerometer)
- Data communication by BLE 4.0 (GATT Profile)
- OBD communication by 2.4G (non-standard Profile) for Speed input
- Support BLE 4.0 (GATT Profile)
- Support 2.4G (non-standard Profile) for Speed input
- Support Google、Baidu、map for real-time navigation
- Small form factor 96.0 x 63.0 x 14.7 mm
- RoHS compliant

3 Application

- Automotive navigation
- Fleet management

4 System Block Diagram

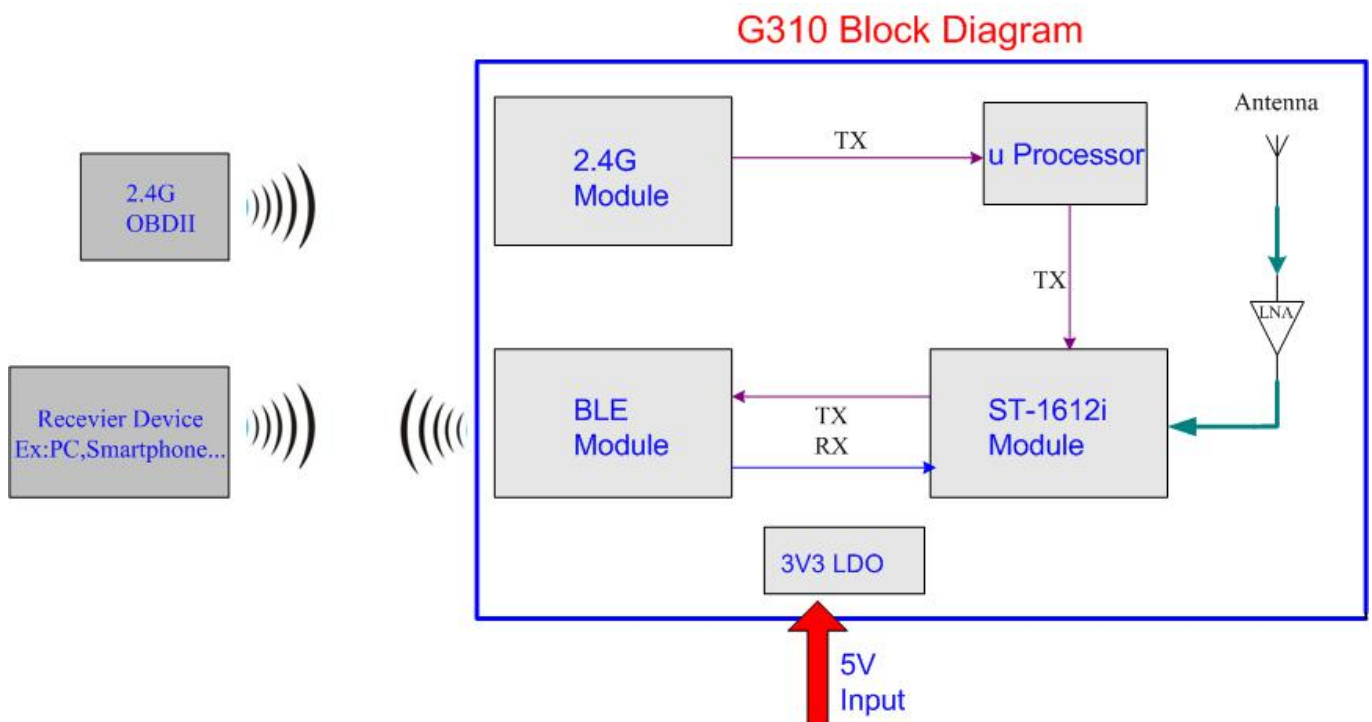

Fig 4-1 System block diagram.

5 Specification

5.1 GNSS receiver⁽¹⁾

Chip	STA8090FGB series	
Frequency	GPS, GALILEO, QZSS: L1 1575.42MHz, C/A code GLONASS: L1 1598.0625MHz ~ 1605.375MHz, C/A code	
Channels	Support 48 channels	
Update rate	1Hz default	
Sensitivity	Tracking	-163dBm
	Cold start	-147dBm
Acquisition Time	Cold Start (Open Sky)	36s (typical)
	Hot Start (Open Sky)	1s (typical)
Position Accuracy	Autonomous	1.8m CEP
	SBAS	1.5m (depends on accuracy of correction data)
Max. Altitude	< 18,000 m	
Max. Velocity	< 515 m/s	
Protocol Support	NMEA 0183 ver 3.01	115200 bps, 8 data bits, no parity, 1 stop bits 1Hz: GGA, GLL, GSA, GSV, RMC, VTG, ZDA

Note1: Measured by ST-1612i-DGU module.

5.2 BLE 4.0 (GATT Profile)

Parameter	Min	Typical	Max	Unit
Operate Frequency	2402		2480	MHz
Modulation 20dB Bandwidth		1		MHz
RXSENS-1Mbps BER-0.001		-89		dBm
Maximum Received Signal	0			dBm
Output power			5	dBm
Link of baud rate		115200		Bit/s

5.3 2.4G (non-standard Profile)

Parameter	Min	Typical	Max	Unit
Operate Frequency	2402		2480	MHz
Modulation 20dB Bandwidth	1.6	2	2.5	MHz
RXSENS-1Mbps BER-0.001		-87		dBm
Maximum Received Signal			10	dBm
Output power			3	dBm
Link of baud rate		38400		Bit/s

6 DC & Temperature characteristics

6.1 Absolute maximum ratings

Parameter	Symbol	Ratings	Units
Input Voltage	VCC	5	V
Operating Temperature Range	Topr	-20 ~ 70	°C
Storage Temperature Range	Tstg	-20 ~ 70	°C

6.2 DC Electrical characteristics

Parameter	Symbol	Conditions	Min.	Typ.	Max.	Units
Input Voltage	VCC		4.75	5	5.25	V
Supply Current	Iss	Acquisition		118		mA
		Tracking		123 ⁽¹⁾		mA
		Peak		284		mA

Note1: Measured when position fix (1Hz) is available.

6.3 Temperature characteristics

Parameter	Symbol	Min.	Typ.	Max.	Units
Operating Temperature	Topr	-20	-	70	°C
Storage Temperature	Tstg	-20	25	70	°C

7 Mechanical specification

7.1 Recommended Mounting

Please refer to the following figure to mount the LOCOSYS G310 on vehicle. The module should be securely mounted to a stable part of the vehicle.

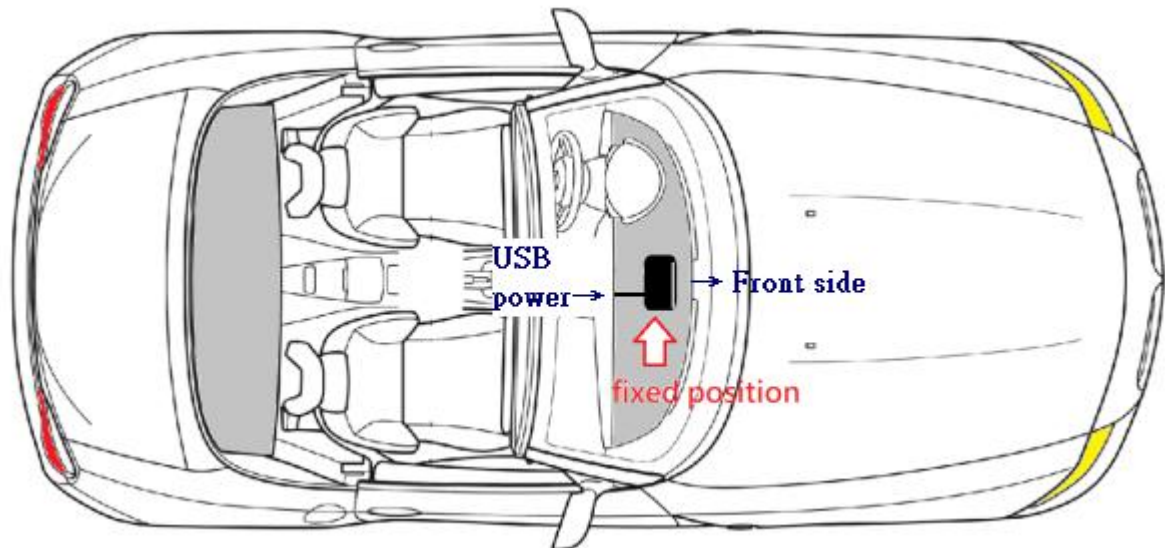

Note1: The LOCOSYS G310 MUST mount horizontally on vehicle (when the vehicle is on a level surface) and toward the front of vehicle. (Default is standard installation method)

Note2: If the system is not mounted as the above figure, please consult LOCOSYS in advance.

7.2 Outline dimensions

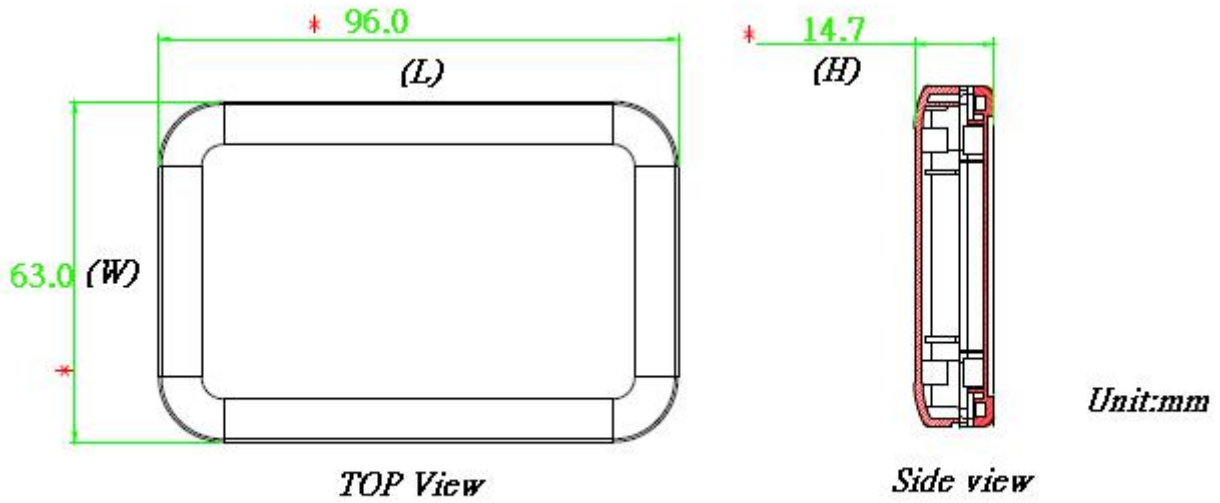

Symbol	Min. (mm)	Typ. (mm)	Max. (mm)
W	62.5	63.0	63.5
L	95.5	96.0	96.5
H	14.2	14.7	15.2

8 Software interface

8.1 NMEA output message

Table 8.1-1 NMEA output message

NMEA record	Description
GGA	Global positioning system fixed data
GLL	Geographic position - latitude/longitude
GSA	GNSS DOP and active satellites
GSV	GNSS satellites in view
RMC	Recommended minimum specific GNSS data
VTG	Course over ground and ground speed
ZDA	UTC, day, month and year.

- **GGA--- Global Positioning System Fixed Data**

Table 8.1-2 contains the values for the following example:

\$GNGGA,013654.000,2503.71447,N,12138.74593,E,1,16,0.7,130.00,M,15.3,M,,*72

Table 8.1- 2 GGA Data Format

Name	9 Example	Units	Description
Message ID	\$GNGGA		GGA protocol header
UTC Time	013654.000		hhmmss.sss
Latitude	2503.71447		ddmm.mmmmm
N/S indicator	N		Latitude Direction: North or South
Longitude	12138.74593		dddmm.mmmmm
E/W Indicator	E		Longitude Direction: East or West
Position Fix Indicator	1		See Table 8.1-3
Satellites Used	16		Satellites in use
HDOP	0.7		Horizontal Dilution of Precision,max:99.0
MSL Altitude	130.00	meters	Height above mean sea level
Units	M	meters	Reference Unit for Altitude (“M” = meters)
Geoidal Separation	15.3	meters	Geoidal Separation measure in “M” = meters
Units	M	meters	Reference Unit for Geoidal Separation (“M” = meters)
DGPS Age			Not supported
DGPS Reference			Not supported
Checksum	*72		
<CR> <LF>			End of message termination

Table 8.1-3 Position Fix Indicators

Value	Description
0	Fix not available or invalid
1	GNSS fix valid
2	Differential GNSS fix valid
3-5	Not supported
6	Estimated (Dead Reckoning) Mode

- **GLL--- Geographic Position – Latitude/Longitude**

Table 8.1-4 contains the values for the following example:

\$GNGLL,2503.71447,N,12138.74593,E,013654.000,A,A*42

Table 8.1-4 GLL Data Format

10 Name	Example	Units	Description
Message ID	\$GNGLL		GLL protocol header
Latitude	2503.71447		ddmm.mmmmm
N/S indicator	N		Latitude Direction: North or South
Longitude	12138.74593		dddmm.mmmmm
E/W indicator	E		Longitude Direction: East or West
UTC Time	013654.000		hhmmss.sss
Status	A		Validity of Data; A=data valid or V=data invalid
Mode	A		A = Autonomous mode, D = Differential mode, E = Estimated (Dead Reckoning) Mode, N=Data invalid,
Checksum	*42		
<CR> <LF>			End of message termination

- **GSA---GNSS DOP and Active Satellites**

Table 8.1-5 contains the values for the following example:

\$GNGSA,A,3,05,24,15,21,10,18,13,12,20,32,,1.1,0.7,0.9*2C

\$GNGSA,A,3,70,69,84,85,68,,,,,,,,,1.1,0.7,0.9*25

\$GNGSA,A,3,193,,,,,,,,,,,,,1.1,0.7,0.9*19

\$GNGSA,A,3,,,,,,,,,,,,,1.1,0.7,0.9*22

\$GNGSA,A,3,,,,,,,,,,,,,1.1,0.7,0.9*22

Table 8.1-5 GSA Data Format

Name	Example	Units	Description
Message ID	\$GNGSA		GSA protocol header
Mode 1	A		See Table 8.1-6

Mode 2	3		See Table 8.1-7
ID of satellite used	05		Sv on Channel 1
ID of satellite used	24		Sv on Channel 2
....		
ID of satellite used			Sv on Channel 12
PDOP	1.1		Position Dilution of Precision,max:99.0
HDOP	0.7		Horizontal Dilution of Precision, max:99.0
VDOP	0.9		Vertical Dilution of Precision, max:99.0
Checksum	*2C		
<CR> <LF>			End of message termination

Table 8.1-6 Mode 1

Value	Description
M	Manual: forced to operate in 2D or 3D mode
A	Automatic: allowed to automatically switch 2D/3D

Table 8.1-7 Mode 2

Value	Description
1	No Fix available
2	2D
3	3D

● GSV--GNSS Satellites in View

Table 8.1-8 contains the values for the following example:

```
$GNGSV,6,1,24,03,71,305,46,05,51,197,,11,08,327,45,15,18,289,*68
$GNGSV,6,2,24,16,35,215,45,18,68,103,,19,32,133,,25,23,012,*6B
$GNGSV,6,3,24,30,25,179,45,31,30,139,46,32,34,290,,74,17,006,44*68
$GNGSV,6,4,24,65,41,320,45,76,41,320,45,76,38,265,,75,45,311,*6A
$GNGSV,6,5,24,69,41,320,,70,24,142,,86,09,193,,80,41,320,*6F
$GNGSV,6,6,24,70,08,144,,85,11,142,44,71,56,108,44,72,47,004,43*6C
```

Table 8.1-8 GSV Data Format

Name	Example	Units	Description
Message ID	\$GNGSV		GSV protocol header
Total number of messages ¹	6		Range 1 to 8
Message number ¹	1		Range 1 to 8
Satellites in view	24		Total Number of Satellites in view
Satellite ID	03		Channel 1 (Range 01 to 330)

Elevation	71	degrees	Channel 1 (Range 00 to 90)
Azimuth	305	degrees	Channel 1 (Range 000 to 359)
SNR (C/No)	46	dB-Hz	Channel 1 (Range 00 to 99, null when not tracking)
.....		
Satellite ID	15		Channel 4 (Range 01 to 330)
Elevation	18	degrees	Channel 4 (Range 00 to 90)
Azimuth	289	degrees	Channel 4 (Range 000 to 359)
SNR (C/No)		dB-Hz	Channel 4 (Range 00 to 99, null when not tracking)
Checksum	*68		
<CR> <LF>			End of message termination

Note1: Depending on the number of satellites tracked multiple messages of GSV data may be required.

Note2: GPS ID: 01~32, SBAS ID: 33~51, QZSS ID: 183~197, GLONASS ID: 65~92, GALILEO:301~330

● RMC---Recommended Minimum Specific GNSS Data

Table 8.1-9 contains the values for the following example:

\$GNRMC,015924.000,A,2503.71417,N,12138.74623,E,0.1,0.0,230217,,,D*77

Table 8.1-9 RMC Data Format

Name	Example	Units	Description
Message ID	\$GNRMC		RMC protocol header
UTC Time	015924.000		hhmmss.sss
Status	A		A=data valid or V=data invalid
Latitude	2503.71417		ddmm.mmmmm
N/S Indicator	N		Latitude Direction: North or South
Longitude	12138.74623		dddmm.mmmmm
E/W Indicator	E		Longitude Direction: East or West
Speed over ground	0.1	knots	Speed over ground in knots
Course over ground	0.0	degrees	Course made good,max
Date	230217		ddmmyy
Magnetic variation		degrees	
Variation sense			Magnetic Variation Direction: East or West
Mode	D		A = Autonomous mode, D = Differential mode, E = Estimated (Dead Reckoning) mode, N=Data invalid
Checksum	*77		
<CR> <LF>			End of message termination

● **VTG---Course Over Ground and Ground Speed**

Table 8.1-10 contains the values for the following example:

\$GNVTG,0.0,T,,M,0.1,N,0.1,K,D*16

Table 8.1-10 VTG Data Format

Name	Example	Units	Description
Message ID	\$GNVTG		VTG protocol header
Course over ground	0.0	degrees	Reference to “true” earth poles
Reference	T		Indicates “terrestrial”
Course over ground		degrees	Reference to “magnetic” earth poles
Reference	M		Indicates “Magnetic”
Speed over ground	0.1	knots	Speed over ground in knots
Units	N		Indicates “Knots”
Speed over ground	0.1	km/h	Speed over ground in kilometers per hour
Units	K		Indicates “Kilometers per hour”
Mode	D		A = Autonomous mode, D = Differential mode, E = Estimated (Dead Reckoning)mode
Checksum	*16		
<CR> <LF>			End of message termination

● **ZDA---UTC, day, month and year.**

Table 8.1-11 contains the values for the following example:

\$GNZDA,020849.00,23,02,2017,00,00*78

Table 8.1-11 ZDA Data Format

Name	Example	Units	Description
Message ID	\$GNZDA		ZDA protocol header
Timestamp	020849.00		hhmmss.ss
Day	23		Decimal, 2 digits Day of month (01 to 31)
Month	02		Decimal, 2 digits Month (01 to 12)
Year	2017		Decimal, 4 digits Year (1994 - ...)
Local zone hour	00	hour	Local time zone offset from UTC (set to 00)
Local zone minutes	00	minute	Local time zone offset from UTC (set to 00)
Checksum	*78		
<CR> <LF>			End of message termination

9 Standard package

- I. *G310 System *1*
- II. *2.4G OBDII Dongle *1*
- III. *Micro USB cable *1*

10 Device overview



10.1 LED Description:

- a. When USB power on, you can see red light.
- b. When GNSS fix valid, Blue light blind shine

Document change list

Revision 1.0

- First release on Jul. 26, 2018.

Revision 1.1 (Nov.12.2018)

- modify 2.4G Operate Frequency on page 3.