

Product name	Description	Version
B310	Datasheet of B310 GNSS integrated with embedded DR	1.3



## 1 Introduction

The LOCOSYS B310 product is complete standalone Dead Reckoning (DR) smart antenna system, including an embedded antenna, a ST-1612i-DBU module, a 2.4G module (non-standard Profile), and a BLE 4.0 module (GATT Profile), which designed for a broad spectrum of OEM system applications. The LOCOSYS B310 can simultaneously acquire and track multiple satellite constellations that include GPS, BEIDOU, GALILEO and QZSS. And through the BLE module, the LOCOSYS B310 can be linked to various mobile phones of brands that support BLE, and can retrieve the relevant GNSS messages. The vehicle speed of B310 is from wireless transmission through a OBD II 2.4G dongle. With adverse GNSS conditions in urban canyons, tunnels, or parking garages where DR boosts the accuracy, and the software fills the gaps. And the LOCOSYS B310 can be linked with Google map for real-time navigation functions.

## 2 Features

- SRRC Certification
- Support GPS, BeiDou, GALILEO and QZSS
- Capable of SBAS (WAAS, EGNOS, MSAS)
- 48 tracking channels and 2 fast acquisition channels
- Fast TTFF at low signal level
- Multi colors LED for tasks status display

- Built-in Dead Reckoning (DR) software
- Built-in MEMS sensor (3-axis Gyroscope and 3-axis Accelerometer)
- Data communication by BLE 4.0 (GATT Profile)
- OBD communication by 2.4G (non-standard Profile) for Speed input
- Support BLE 4.0 (GATT Profile)
- Support 2.4G (non-standard Profile) for Speed input
- Support Google、Baidu、map for real-time navigation
- Support Android APP tool
- Small form factor 96.0 x 63.0 x 14.7 mm
- RoHS compliant

### 3 Application

- Automotive navigation
- Fleet management

### 4 System Block Diagram

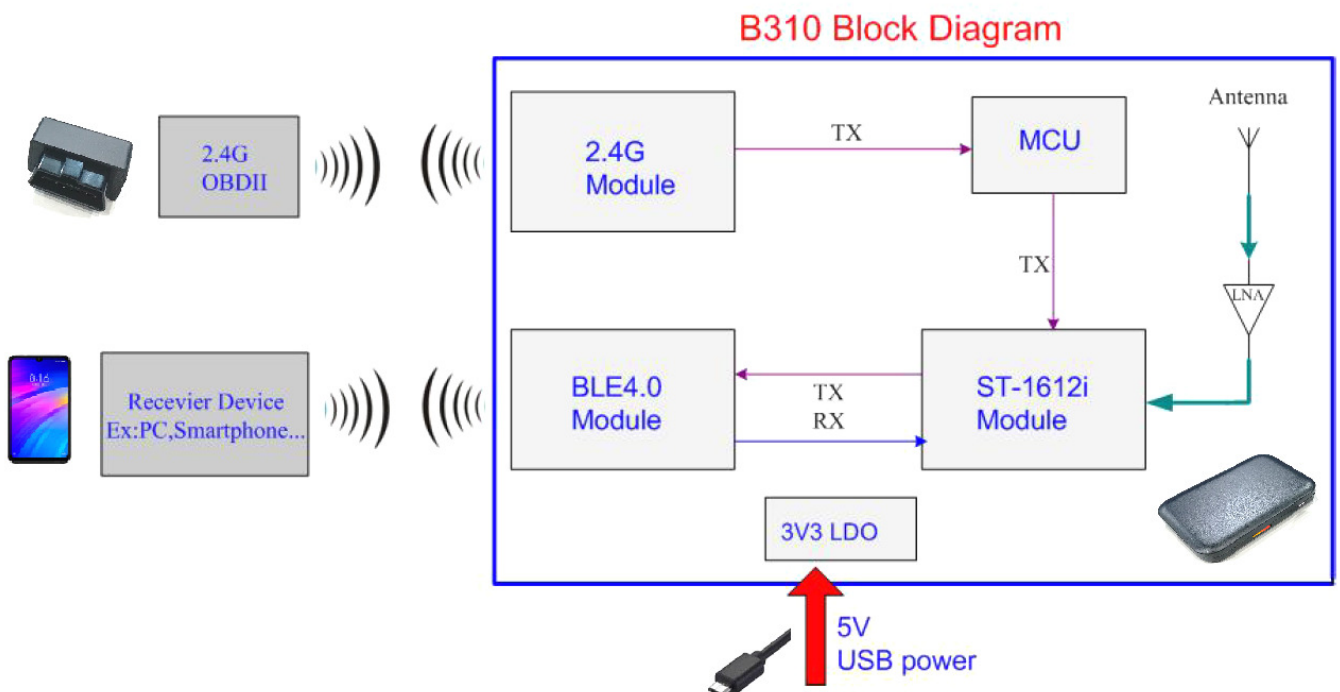

Fig 4-1 System block diagram.

## 5 Specification

### 5.1 GNSS receiver<sup>(1)</sup>

Chip	STA8090FGB series	
Frequency	GPS, GALILEO, QZSS: L1 1575.42MHz, C/A code BeiDou: B1 1561.098MHz, C code	
Channels	Support 48 channels	
Update rate	1Hz default	
Sensitivity	Tracking	-163dBm
	Cold start	-147dBm
Acquisition Time	Cold Start (Open Sky)	36s (typical)
	Hot Start (Open Sky)	1s (typical)
Position Accuracy	Autonomous	1.8m CEP
	SBAS	1.5m (depends on accuracy of correction data)
Max. Altitude	< 18,000 m	
Max. Velocity	< 515 m/s	
Protocol Support	NMEA 0183 ver 3.01	115200 bps, 8 data bits, no parity, 1 stop bits 1Hz <sup>(2)</sup> : GGA, GLL, GSA, GSV, RMC, VTG, ZDA <sup>(2)</sup>

Note1: Measured by ST-1612i-DBU module.

Note2: If needs changes update rate and NMEA sentence, please consult us.

Note3: About high update rate output, please see more detail on page 13.

### 5.2 BLE 4.0 (GATT Profile )

Parameter	Min	Typical	Max	Unit
Operate Frequency	2402		2480	MHz
Modulation 20dB Bandwidth		1		MHz
RXSENS-1Mbps BER-0.001		-89		dBm
Maximum Received Signal	0			dBm
Output power			5	dBm
Link of baud rate		115200		Bit/s

### 5.3 2.4G (non-standard Profile)

Parameter	Min	Typical	Max	Unit
Operate Frequency	2402		2480	MHz
Modulation 20dB Bandwidth	1.6	2	2.5	MHz
RXSENS-1Mbps BER-0.001		-87		dBm
Maximum Received Signal			10	dBm

Output power			3	dBm
Link of baud rate		38400		Bit/s

## 6 DC & Temperature characteristics

### 6.1 Absolute maximum ratings

Parameter	Symbol	Ratings	Units
Input Voltage	VCC	5	V
Operating Temperature Range	Topr	-20 ~ 70	°C
Storage Temperature Range	Tstg	-20 ~ 70	°C

### 6.2 DC Electrical characteristics

Parameter	Symbol	Conditions	Min.	Typ.	Max.	Units
Input Voltage	VCC		4.75	5	5.25	V
Supply Current	Iss	Acquisition		118		mA
		Tracking		123 <sup>(1)</sup>		mA
		Peak		284		mA

Note1: Measured when position fix (1Hz) is available.

### 6.3 Temperature characteristics

Parameter	Symbol	Min.	Typ.	Max.	Units
Operating Temperature	Topr	-20	-	70	°C
Storage Temperature	Tstg	-20	25	70	°C

## 7 Mechanical specification

### 7.1 Recommended Mounting

Please refer to the following figure to mount the LOCOSYS B310 on vehicle. The module should be securely mounted to a stable part of the vehicle.

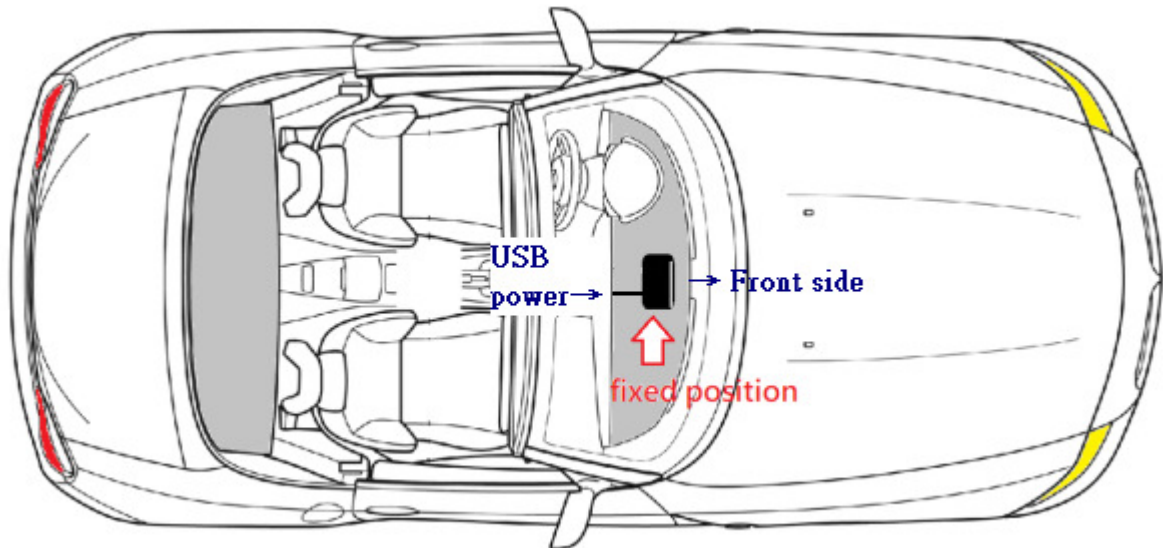

**Note1: The LOCOSYS B310 MUST mount horizontally on vehicle (when the vehicle is on a level surface) and toward the front of vehicle. (Default is standard installation method)**

**Note2: If the system is not mounted as the above figure, please consult LOCOSYS in advance.**

7.2 Outline dimensions

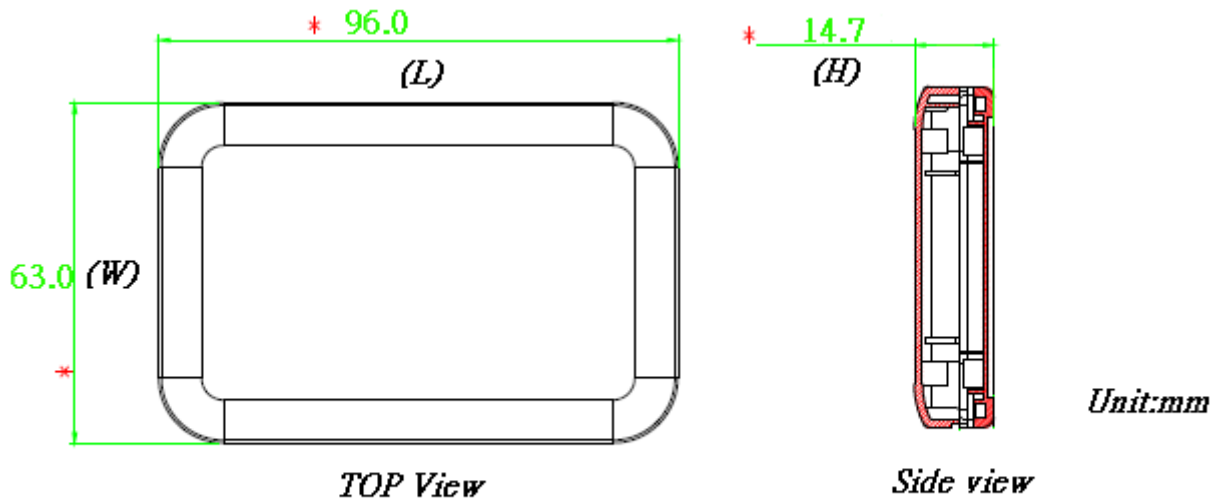

Symbol	Min. (mm)	Typ. (mm)	Max. (mm)
W	62.5	63.0	63.5
L	95.5	96.0	96.5
H	14.2	14.7	15.2

## 8 Software interface

### 8.1 NMEA output message

Table 8.1-1 NMEA output message

NMEA record	Description
GGA	Global positioning system fixed data
GLL	Geographic position - latitude/longitude
GSA	GNSS DOP and active satellites
GSV	GNSS satellites in view
RMC	Recommended minimum specific GNSS data
VTG	Course over ground and ground speed
ZDA	UTC, day, month and year.
GST	UTC, Global Positioning System Pseudorange Noise Statistics.(option)

- **GGA--- Global Positioning System Fixed Data**

Table 8.1-2 contains the values for the following example:

\$GNGGA,013654.000,2503.71447,N,12138.74593,E,1,16,0.7,130.00,M,15.3,M,,\*72

Table 8.1- 2 GGA Data Format

Name	2	Example	Units	Description
Message ID		\$GNGGA		GGA protocol header
UTC Time		013654.000		hhmmss.sss
Latitude		2503.71447		ddmm.mmmmm
N/S indicator		N		Latitude Direction: North or South
Longitude		12138.74593		dddmm.mmmmm
E/W Indicator		E		Longitude Direction: East or West
Position Fix Indicator		1		See Table 8.1-3
Satellites Used		16		Satellites in use
HDOP		0.7		Horizontal Dilution of Precision,max:99.0
MSL Altitude		130.00	meters	Height above mean sea level
Units		M	meters	Reference Unit for Altitude (“M” = meters)
Geoidal Separation		15.3	meters	Geoidal Separation measure in “M” = meters
Units		M	meters	Reference Unit for Geoidal Separation (“M” = meters)
DGPS Age				Not supported
DGPS Reference				Not supported
Checksum		*72		

<CR> <LF>			End of message termination
-----------	--	--	----------------------------

Table 8.1-3 Position Fix Indicators

Value	Description
0	Fix not available or invalid
1	GNSS fix valid
2	Differential GNSS fix valid
3-5	Not supported
6	Estimated (Dead Reckoning) Mode

- **GLL--- Geographic Position – Latitude/Longitude**

Table 8.1-4 contains the values for the following example:

\$GNGLL,2503.71447,N,12138.74593,E,013654.000,A,A\*42

Table 8.1-4 GLL Data Format

Name	Example	Units	Description
Message ID	\$GNGLL		GLL protocol header
Latitude	2503.71447		ddmm.mmmmm
N/S indicator	N		Latitude Direction: North or South
Longitude	12138.74593		dddmm.mmmmm
E/W indicator	E		Longitude Direction: East or West
UTC Time	013654.000		hhmmss.sss
Status	A		Validity of Data; A=data valid or V=data invalid
Mode	A		A = Autonomous mode, D = Differential mode, E = Estimated (Dead Reckoning) Mode, N=Data invalid,
Checksum	*42		
<CR> <LF>			End of message termination

- **GSA---GNSS DOP and Active Satellites**

Table 8.1-5 contains the values for the following example:

\$GNGSA,A,3,05,24,15,21,10,18,13,12,20,32,,1.1,0.7,0.9\*2C

\$GNGSA,A,3,70,69,84,85,68,,,,,,,,1.1,0.7,0.9\*25

\$GNGSA,A,3,193,,,,,,,,,1.1,0.7,0.9\*19

\$GNGSA,A,3,,,,,,,,,1.1,0.7,0.9\*22

\$GNGSA,A,3,,,,,,,,,1.1,0.7,0.9\*22

Table 8.1-5 GSA Data Format

Name	Example	Units	Description
Message ID	\$GNGSA		GSA protocol header



Mode 1	A		See Table 8.1-6
Mode 2	3		See Table 8.1-7
ID of satellite used	05		Sv on Channel 1
ID of satellite used	24		Sv on Channel 2
....			....
ID of satellite used			Sv on Channel 12
PDOP	1.1		Position Dilution of Precision,max:99.0
HDOP	0.7		Horizontal Dilution of Precision, max:99.0
VDOP	0.9		Vertical Dilution of Precision, max:99.0
Checksum	*2C		
<CR> <LF>			End of message termination

Table 8.1-6 Mode 1

Value	Description
M	Manual: forced to operate in 2D or 3D mode
A	Automatic: allowed to automatically switch 2D/3D

Table 8.1-7 Mode 2

Value	Description
1	No Fix available
2	2D
3	3D

## ● GSV---GNSS Satellites in View

Table 8.1-8 contains the values for the following example:

\$GNGSV,6,1,24,03,71,305,46,05,51,197,,11,08,327,45,15,18,289,\*68

\$GNGSV,6,2,24,16,35,215,45,18,68,103,,19,32,133,,25,23,012,\*6B

\$GNGSV,6,3,24,30,25,179,45,31,30,139,46,32,34,290,,74,17,006,44\*68

\$GNGSV,6,4,24,65,41,320,45,76,41,320,45,76,38,265,,75,45,311,\*6A

\$GNGSV,6,5,24,69,41,320,,70,24,142,,86,09,193,,80,41,320,\*6F

\$GNGSV,6,6,24,70,08,144,,85,11,142,44,71,56,108,44,72,47,004,43\*6C

Table 8.1-8 GSV Data Format

Name	Example	Units	Description
Message ID	\$GNGSV		GSV protocol header
Total number of messages <sup>1</sup>	6		Range 1 to 8
Message number <sup>1</sup>	1		Range 1 to 8
Satellites in view	24		Total Number of Satellites in view

Satellite ID	03		Channel 1 (Range 01 to 330)
Elevation	71	degrees	Channel 1 (Range 00 to 90)
Azimuth	305	degrees	Channel 1 (Range 000 to 359)
SNR (C/No)	46	dB-Hz	Channel 1 (Range 00 to 99, null when not tracking)
.....			.....
Satellite ID	15		Channel 4 (Range 01 to 330)
Elevation	18	degrees	Channel 4 (Range 00 to 90)
Azimuth	289	degrees	Channel 4 (Range 000 to 359)
SNR (C/No)		dB-Hz	Channel 4 (Range 00 to 99, null when not tracking)
Checksum	*68		
<CR> <LF>			End of message termination

Note1: Depending on the number of satellites tracked multiple messages of GSV data may be required.

Note2: GPS ID: 01~32, SBAS ID: 33~51, QZSS ID: 183~197, GLONASS ID: 65~92, GALILEO ID: 301~330

## ● RMC---Recommended Minimum Specific GNSS Data

Table 8.1-9 contains the values for the following example:

\$GNRMC,015924.000,A,2503.71417,N,12138.74623,E,0.1,0.0,230217,,D\*77

Table 8.1-9 RMC Data Format

Name	Example	Units	Description
Message ID	\$GNRMC		RMC protocol header
UTC Time	015924.000		hhmmss.sss
Status	A		A=data valid or V=data invalid
Latitude	2503.71417		ddmm.mmmmm
N/S Indicator	N		Latitude Direction: North or South
Longitude	12138.74623		dddmm.mmmmm
E/W Indicator	E		Longitude Direction: East or West
Speed over ground	0.1	knots	Speed over ground in knots
Course over ground	0.0	degrees	Course made good,max
Date	230217		ddmmyy
Magnetic variation		degrees	
Variation sense			Magnetic Variation Direction: East or West
Mode	D		A = Autonomous mode, D = Differential mode, E = Estimated (Dead Reckoning) mode, N=Data invalid
Checksum	*77		
<CR> <LF>			End of message termination

- **VTG---Course Over Ground and Ground Speed**

Table 8.1-10 contains the values for the following example:

\$GNVTG,0.0,T,,M,0.1,N,0.1,K,D\*16

Table 8.1-10 VTG Data Format

Name	Example	Units	Description
Message ID	\$GNVTG		VTG protocol header
Course over ground	0.0	degrees	Reference to “true” earth poles
Reference	T		Indicates “terrestrial”
Course over ground		degrees	Reference to “magnetic” earth poles
Reference	M		Indicates “Magnetic”
Speed over ground	0.1	knots	Speed over ground in knots
Units	N		Indicates “Knots”
Speed over ground	0.1	km/h	Speed over ground in kilometers per hour
Units	K		Indicates “Kilometers per hour”
Mode	D		A = Autonomous mode, D = Differential mode, E = Estimated (Dead Reckoning)mode
Checksum	*16		
<CR> <LF>			End of message termination

- **ZDA---UTC, day, month and year.**

Table 8.1-11 contains the values for the following example:

\$GNZDA,020849.00,23,02,2017,00,00\*78

Table 8.1-11 ZDA Data Format

Name	Example	Units	Description
Message ID	\$GNZDA		ZDA protocol header
Timestamp	020849.00		hhmmss.ss
Day	23		Decimal, 2 digits Day of month (01 to 31)
Month	02		Decimal, 2 digits Month (01 to 12)
Year	2017		Decimal, 4 digits Year (1994 - ...)
Local zone hour	00	hour	Local time zone offset from UTC (set to 00)
Local zone minutes	00	minute	Local time zone offset from UTC (set to 00)
Checksum	*78		
<CR> <LF>			End of message termination

● **GST---UTC, Global Positioning System Pseudorange Noise Statistics**

Table 8.1-12 contains the values for the following example:

\$GNGST,033047.250,9.0,3.9,3.3,90.2,3.3,3.9,3.2\*4E

Table 8.1-12 GST Data Format

Name	Example	Units	Description
Message ID	\$GNGST		GST protocol header
Timestamp	033047.250	hhmmss.sss	UTC Time of GPS Sample, example: 160836.000 “.sss” is the fraction of seconds; it assumes non zero values when the fix rate is bigger than 1Hz.
EHPE	9.0	dd.d in m	Equivalent Horizontal Position Error
Semi-major Dev	3.9	dd.d in m	Standard deviation (meters) of semi-major axis of error ellipse
Semi-minor Dev	3.3	dd.d in m	Standard deviation (meters) of semi-minor axis of error ellipse
Semi-major Angle	90.2	dd.d in degree	Orientation of semi-major axis of error ellipse (true north degrees)
Lat Err Dev	3.3	dd.d in m	Standard deviation (meters) of latitude error
Lon Err Dev	3.9	dd.d in m	Standard deviation (meters) of longitude error
Alt Err Dev	3.2	dd.d in m	Standard deviation (meters) of altitude error
Checksum	*4E		
<CR> <LF>			End of message termination

8.2 Proprietary input/output message

Table 8.2-1 The table below summarizes the set of proprietary command sets for the B310

Software command	Command descriptions
\$PSTMDRGPS	Reports GNSS fix quality metrics.(option)

● **\$PSTMDRGPS---Reports GNSS fix quality metrics.**

Table 8.2-2 contains the values for the following example:

\$PSTMDRGPS,25.057296367,121.620466268,-0.00287,-0.02948,1.387,0.688,1.203,6.280,0.023,-0.06335,4.8\*50

Table 8.2-2 \$PSTMDRGPS Data Format

Name	Example	Units	Description
Message ID	\$PSTMDRGPS		PSTMDRGPS protocol header
Lat	25.057296367	degrees	Decimal degrees
Lon	121.620466268	degrees	Decimal degrees
Vn	-0.00287	meters/second	Velocity’s north vector component,in meters/second
Ve	-0.02948	meters/second	Velocity’s east vector component,in meters/second
PDOP	1.387		Position dilution of precision

HDOP	0.688		Horizontal dilution of precision
VDOP	1.203		Vertical dilution of precision
Rms_pos_residual	6.280	meters	Meters
Rms_vel_residual	0.023	meters	Meters
Vv	-0.06335		Velocity's vertical vector component, in meters/second
Height	4.8		Meters
Checksum	*50		
<CR> <LF>			End of message termination

9 High update rate output sentence:

Update rate	Output sentence
1Hz	GGA, GLL, GSA, GSV, RMC, VTG, ZDA
4Hz	GGA,RMC,GST,PSTMDRGPS
15Hz	GGA,RMC

10 OBDII support protocol:

- SAE-J1850 PWM (41.6 kbaud)*
- SAE-J1850 VPW (10.4 kbaud)*
- ISO 9141-2 (5 baud init, 10.4 kbaud)*
- ISO 14230-4 KWP (5 baud init, 10.4 kbaud)*
- ISO 14230-4 KWP (fast init, 10.4 kbaud)*
- ISO 14230-4 KWP2000*
- ISO 15765-4 CAN (11 bit ID, 500 kbaud)*
- ISO 15765-4 CAN (29 bit ID, 500 kbaud)*
- ISO 15765-4 CAN (11 bit ID, 250 kbaud)*
- ISO 15765-4 CAN (29 bit ID, 250 kbaud)*

*Example:*

- Lexus & Toyota series (Carola, Camry, Yaris, RAV4)*
- Honda series (Fit, Accord, City, Civic, CRV)*
- Mazda series (2,3,5)*
- Nissan series (TIIDA, Livian,Teana)*
- etc...*

*Support the partial models after 2008 manufacture. Currently, support 95% of the models after 2008 manufacture.*

## 11 Standard package

- I. *B310 System \*1*
- II. *2.4G OBDII Dongle \*1*
- III. *Micro USB cable \*1*

## 12 Device overview



### 12.1 LED Description:

- a. When USB power on, you can see red light.
- b. When GNSS fix valid, Blue light blind shine

## Document change list

### Revision 1.0

- First release on Jul. 26, 2018.

### Revision 1.1 (Nov.12.2018)

- Modify 2.4G Operate Frequency on page 3.

### Revision 1.2 (Feb.21.2019)

- Add SRRC certification on page 1.
- Modify system block diagram on page 2.

### Revision 1.3 (May.07.2019)

- Modify features on page 2.
- Modify system block diagram on page 2.
- Add NMEA sentence and update rate info on page 7 and 12~13.
- Add OBDII support protocol on page 13.