

Product name	Description	Version
B310-U	Datasheet of B310-U GNSS integrated with embedded DR	0.1



1 Introduction

LOCOSYS B310-U is a BLE enabled GNSS receiver with dead reckoning function. It consists of an embedded GNSS antenna, MC-1612-DB GNSS module, 3-axis gyroscope, 3-axis accelerometer and BLE 4.0 function. It can simultaneously receive multiple satellite constellations that include GPS, GLNOASS, GALILEO and QZSS. Together with GNSS, dead reckoning and BLE, B310-U can provide the most mobile phones the seamless position and better navigation even in urban canyons, tunnels and underground parking lots.

2 Features

- Support GPS, BEIDOU, GALILEO and QZSS
- Capable of SBAS (WAAS, EGNOS, MSAS, GAGAN)
- 99 tracking channels
- Fast TTFF at low signal level
- Multi colors LED for tasks status display
- Built-in Dead Reckoning (DR) software
- Built-in MEMS sensor (3-axis Gyroscope and 3-axis Accelerometer)
- Data communication by BLE 4.0 (GATT Profile)
- Support BLE 4.0 (GATT Profile)
- Support Google、Baidu、map for real-time navigation
- Support Android APP tool

- Small form factor 96.0 x 63.0 x 14.7 mm
- RoHS compliant

3 Application

- Automotive navigation
- Fleet management

4 System Block Diagram

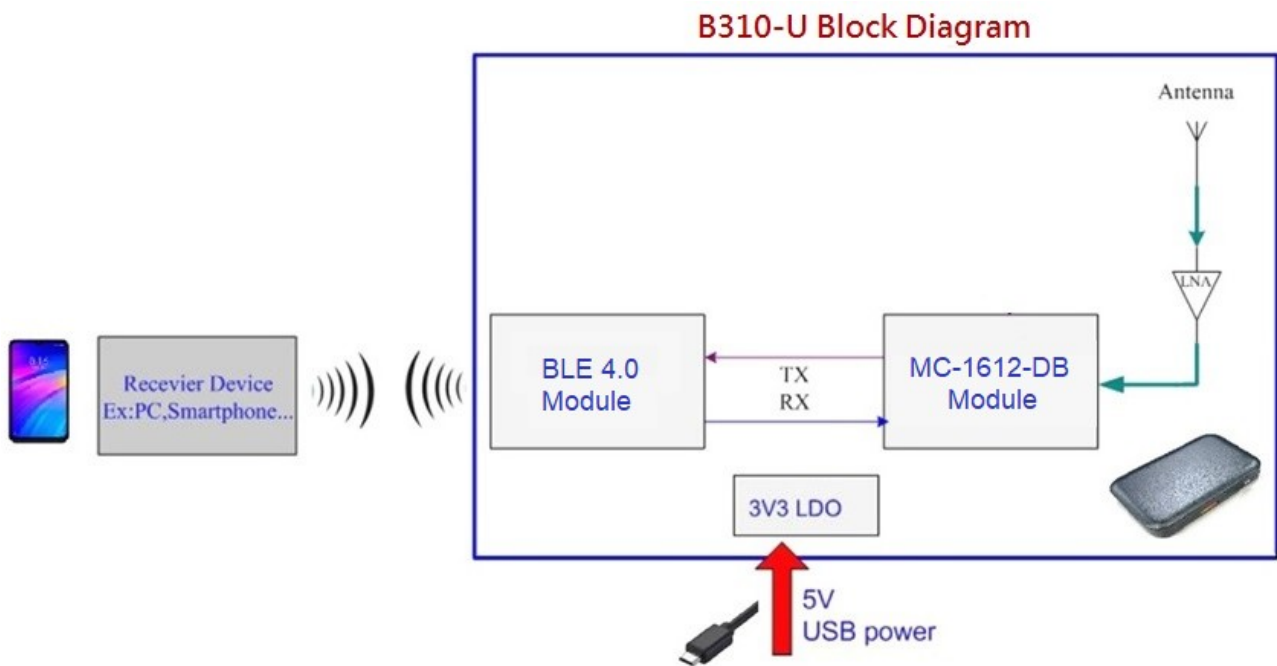

Fig 4-1 System block diagram

5 Specification

5.1 GNSS receiver⁽¹⁾

Chip	GNSS chip	
Frequency	GPS, GALILEO, QZSS: L1 1575.42MHz, C/A code BEIDOU:B1 1561.098MHz, C code	
Channels	Support 99 channels (33 Tracking, 99 Acquisition)	
Update rate	1Hz default, up to 10Hz (Option)	
MEMS Raw data update rate	100Hz	
Sensitivity	Tracking	up to -163dBm (with external LNA)
	Cold start	up to -148dBm (with external LNA)
Acquisition Time	Hot start (Open Sky)	<1 s (typical)
	Cold Start (Open Sky)	34s (typical)
Position Accuracy	Autonomous	2.5m (CEP)
	SBAS	2.5m (CEP, depends on accuracy of correction data)
	UDR Mode	Avg 5.0 %
Max. Altitude	< 18,000 m	
Max. Velocity	< 515 m/s	
Protocol Support	NMEA 0183 ver 4.10	115200 bps, 8 data bits, no parity, 1 stop bits (default) 1Hz ⁽²⁾ : GGA, GSA, RMC, PLSVD, GST and \$PINVMINR ⁽²⁾

Note1: Measured by MC-1612-DB module.

Note2: If needs changes update rate and NMEA sentence, please consult us.

5.2 BLE 4.0 (GATT Profile)

Parameter	Min	Typical	Max	Unit
Operate Frequency	2402		2480	MHz
Modulation 20dB Bandwidth		1		MHz
RXSENS-1Mbps BER-0.001		-89		dBm
Maximum Received Signal	0			dBm
Output power			5	dBm
Link of baud rate		115200		Bit/s

6 DC & Temperature characteristics

6.1 Absolute maximum ratings

Parameter	Symbol	Ratings	Units
Input Voltage	VCC	5	V
Operating Temperature Range	Topr	-20 ~ 70	°C
Storage Temperature Range	Tstg	-20 ~ 70	°C

6.2 DC Electrical characteristics

Parameter	Symbol	Conditions	Min.	Typ.	Max.	Units
Input Voltage	VCC		4.75	5	5.25	V
Supply Current	Iss	Acquisition		88		mA
		Tracking		90 ⁽¹⁾		mA
		Peak		289		mA

Note1: Measured when position fix (1Hz) is available.

6.3 Temperature characteristics

Parameter	Symbol	Min.	Typ.	Max.	Units
Operating Temperature	Topr	-20	-	70	°C
Storage Temperature	Tstg	-20	25	70	°C

7 Mechanical specification

7.1 Recommended Mounting

Please refer to the following figure to mount the LOCOSYS B310-U on vehicle. The module should be securely mounted to a stable part of the vehicle.

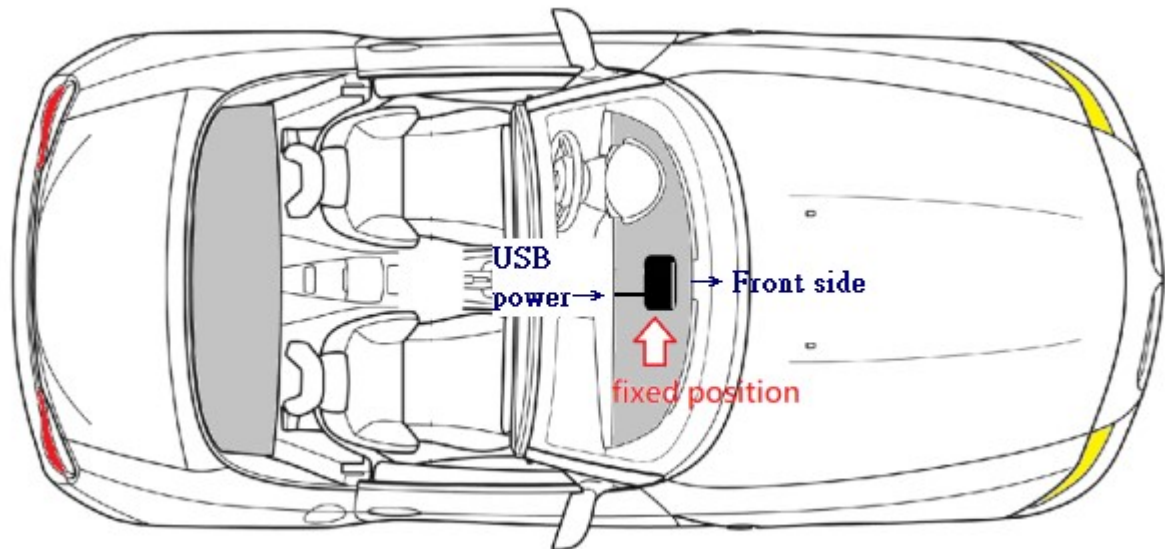

Note1: The LOCOSYS B310-U MUST mount horizontally on vehicle (when the vehicle is on a level surface) and toward the front of vehicle. (Default is standard installation method)

Note2: If the system is not mounted as the above figure, please consult LOCOSYS in advance.

8 Software interface

8.1 NMEA output message

Table 8.1-1 NMEA output message

NMEA record	Description
GGA	Global positioning system fixed data
GSA	GNSS DOP and active satellites
RMC	Recommended minimum specific GNSS data
PLSVD	3D velocity & deviation information
GST	Estimated Position Error

● **GGA--- Global Positioning System Fixed Data**

Table 8.1-2 contains the values for the following example:

\$GNGGA,075754.00,2503.71213,N,12138.74302,E,2,16,0.81,143.20,M,15.32,M,,0000*43

Table 8.1- 2 GGA Data Format

Name	Example	Units	Description
Message ID	\$GNGGA		GGA protocol header
UTC Time	075754.00		hhmmss.ss
Latitude	2503.71213		ddmm.mmmmm
N/S indicator	N		N=north or S=south
Longitude	12138.74302		dddmm.mmmmm
E/W Indicator	E		E=east or W=west
Position Fix Indicator	2		See Table 8.1-3
Satellites Used	16		Range 0 to 33
HDOP	0.81		Horizontal Dilution of Precision
MSL Altitude	143.20	meters	
Units	M	meters	
Geoid Separation	15.32	meters	
Units	M	meters	
DGPS Age			Not supported
DGPS Reference	0000		
Checksum	*43		
<CR> <LF>			End of message termination

Table 8.1-3 Position Fix Indicators

Value	Description
0	Fix not available or invalid

1	GNSS fix valid
2	Differential GNSS fix valid
3-5	Not supported
6	Estimated (Dead Reckoning) Mode

Note: It can bet DGPS (RTCM) or SBAS

● GSA---GNSS DOP and Active Satellites

Table 8.1-4 contains the values for the following example:

\$GNGSA,A,3,13,15,02,29,05,06,195,193,,,,,1.96,0.97,1.70,1*0D

\$GNGSA,A,3,85,71,70,,,,,,,,,1.96,0.97,1.70,2*08

\$GNGSA,A,3,03,15,08,,,,,,,,,1.96,0.97,1.70,3*0A

Table 8.1-4 GSA Data Format

Name	Example	Units	Description
Message ID	\$GNGSA		GSA protocol header
Mode 1	A		See Table 8.1-5
Mode 2	3		See Table 8.1-6
ID of satellite used	13		Sv on Channel 1
ID of satellite used	15		Sv on Channel 2
....		
ID of satellite used			Sv on Channel 12
PDOP	1.96		Position Dilution of Precision
HDOP	0.97		Horizontal Dilution of Precision
VDOP	1.70		Vertical Dilution of Precision
GNSS System ID	1		1: GPS, 2: BEIDOU, 3: GALILEO, 4: BEIDOU, 5-F: Reserved
Checksum	*0D		
<CR> <LF>			End of message termination

Table 8.1-5 Mode 1

Value	Description
M	Manual- forced to operate in 2D or 3D mode
A	Automatic-allowed to automatically switch 2D/3D

Table 8.1-6 Mode 2

Value	Description
1	Fix not available
2	2D
3	3D

● RMC---Recommended Minimum Specific GNSS Data

Table 8.1-7 contains the values for the following example:

\$GNRMC,075806.00,A,2503.71220,N,12138.74293,E,0.05,0.00,240720,,D,V*35

Table 8.1-7 RMC Data Format

Name	Example	Units	Description
Message ID	\$GNRMC		RMC protocol header
UTC Time	075806.00		hhmmss.ss
Status	A		A=data valid or V=data not valid
Latitude	2503.71220		ddmm.mmmmm
N/S Indicator	N		N=north or S=south
Longitude	12138.74293		dddmm.mmmmm
E/W Indicator	E		E=east or W=west
Speed over ground	0.05	knots	True
Course over ground	0.00	degrees	
Date	240720		ddmmyy
Magnetic variation		degrees	(Not shown)
Variation sense			E=east or W=west (Not shown)
Mode	D		N = No position fix A = Autonomous GNSS fix D = Differential GNSS fix R = RTK fixed F = RTK float E = Estimated/Dead reckoning fix
Navigational status	V		S = Safe C = Caution U = Unsafe V = Void
Checksum	*35		
<CR> <LF>			End of message termination

● PLSVD---3D velocity & deviation information

Table 8.1-8 contains the values for the following example:

\$PLSVD,1,0,0,11,10,20*6F

Table 8.1-8 GST Data Format

Name	Example	Units	Description
Message ID	\$PLSVD		PLSVD protocol header

True east velocity	1	cm/s	-51500~51500
True north velocity	0	cm/s	-51500~51500
True down velocity	0	cm/s	-10000~10000
Deviation of east velocity	11	cm/s	
Deviation of north velocity	10	cm/s	
Deviation of down velocity	20	cm/s	
Checksum	*6F		
<CR> <LF>			End of message termination

● **GST---Estimated Position Error**

Table 8.1-9 contains the values for the following example:

\$GNGST,081629.000,6.3,4.1,2.4,59.8,0.44,0.45,0.46*7C

Table 8.1-9 GST Data Format

Name	Example	Units	Description
Message ID	\$GNGST		GST protocol header
UTC Time	081629.000		hhmmss.sss
RMS value of the standard deviation of the ranges	6.3		
Standard deviation of semi-major axis of error ellipse	4.1	meters	0~9999999.99
Standard deviation of semi-minor axis of error ellipse	2.4	meters	0~9999999.99
Orientation of semi-major axis of error ellipse	59.8	degree	
Standard deviation of Latitude error	0.44	meters	
Standard deviation of Longitude error	0.45	meters	
Standard deviation of altitude error	0.46	meters	
Checksum	*7C		
<CR> <LF>			End of message termination

8.2 Dead Reckoning input/output messages

Table 8.2-1 The table below summarizes the set of proprietary command sets for the B310-U

NMEA record	Description
\$PINVMINR	Calibration status

- **\$PINVMINR --- Calibration status**

Table 8.2-2 contains the values for the following example:

\$PINVMINR,1*04

Table 8.2-2 \$PINVMINR Data Format

Name	Example	Units	Description
Message ID	\$PINVMINR		\$PINVMINR protocol header
Status	1		0:not initialized 1:calibrating/initializing 2:calibration done
Checksum	*04		
<CR> <LF>			End of message termination

Note: When GNSS positioning is valid, the message appears at NMEA sentence.

9 Output sentence description:

Update rate	Output sentence
1Hz	GGA, GSA, RMC, PLSVD, GST and PINVMINR

10 Standard package

- I. *B310-U System *1*
- II. *Micro USB cable *1*

11 Device overview



11.1 LED Description

- a. The red LED is on when B310-U is powered on.
- b. The blue LED blinks when GNSS fix is available.
- c. The green LED is always on when the BLE is connected to a mobile phone, otherwise it will keep flashing.

Document change list

Revision 0.1

- Draft release on Sep. 07, 2020.