

Product name	Description	Version
MC-1612-B	Standalone multiple GNSS module	1.0

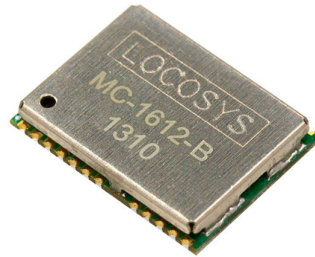

1 Introduction

LOCOSYS MC-1612-B is a complete standalone GNSS module. The module can simultaneously acquire and track multiple satellite constellations that include GPS, BEIDOU, GALILEO, QZSS and SBAS. It features low power and small form factor. Besides, it can provide you with superior sensitivity and performance even in urban canyon and dense foliage environment.

This module supports hybrid ephemeris prediction to achieve faster cold start. One is self-generated ephemeris prediction (called EASY) that is no need of both network assistance and host CPU's intervention. This is valid for up to 3 days and updates automatically from time to time when GNSS module is powered on and satellites are available. The other is server-generated ephemeris prediction (called EPO) that gets from an internet server. This is valid for up to 14 days. Both ephemeris predictions are stored in the on-board flash memory and perform a cold start time less than 15 seconds.

2 Features

- MediaTek high sensitivity solution
- Support GPS, BEIDOU, GALILEO and QZSS
- Capable of SBAS (WAAS, EGNOS, MSAS, GAGAN)
- Support 99-channel GNSS
- Low power consumption
- Fast TTFF at low signal level
- Built-in 12 multi-tone active interference canceller
- Free hybrid ephemeris prediction to achieve faster cold start
- Built-in data logger
- Up to 10 Hz update rate
- ± 1 ns high accuracy time pulse (1PPS)
- Indoor and outdoor multi-path detection and compensation
- Small form factor 16 x 12.2 x 2.2 mm
- SMD type with stamp holes; RoHS compliant
- ISO/TS 16949 quality control

3 Application

- Personal positioning and navigation
- Automotive navigation
- Marine navigation

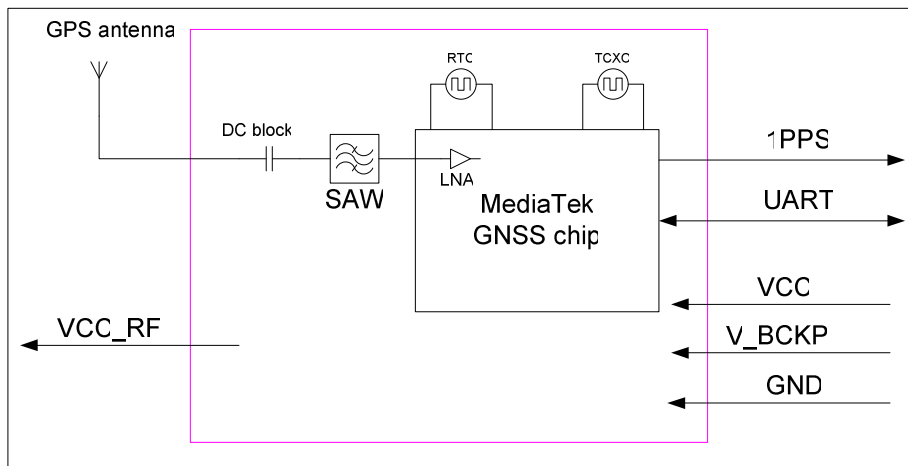

Fig 3-1 System block diagram.

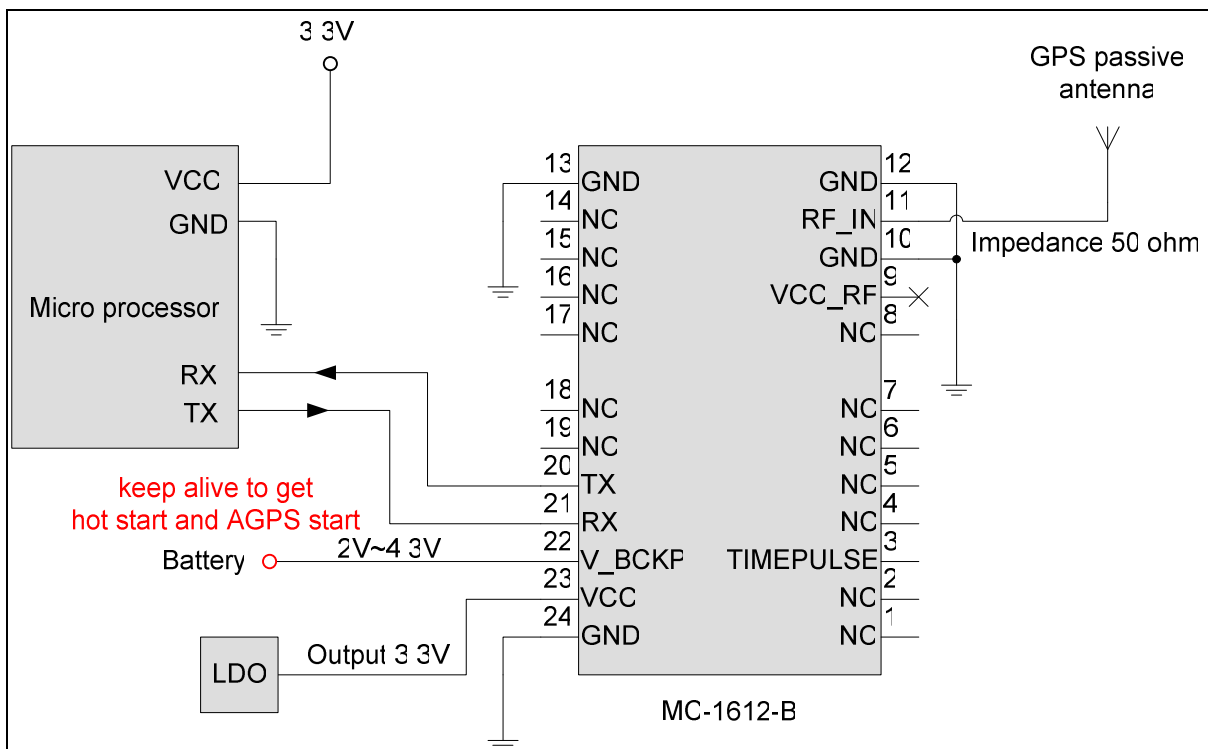

Fig 3-2 Typical application circuit that uses a passive antenna.

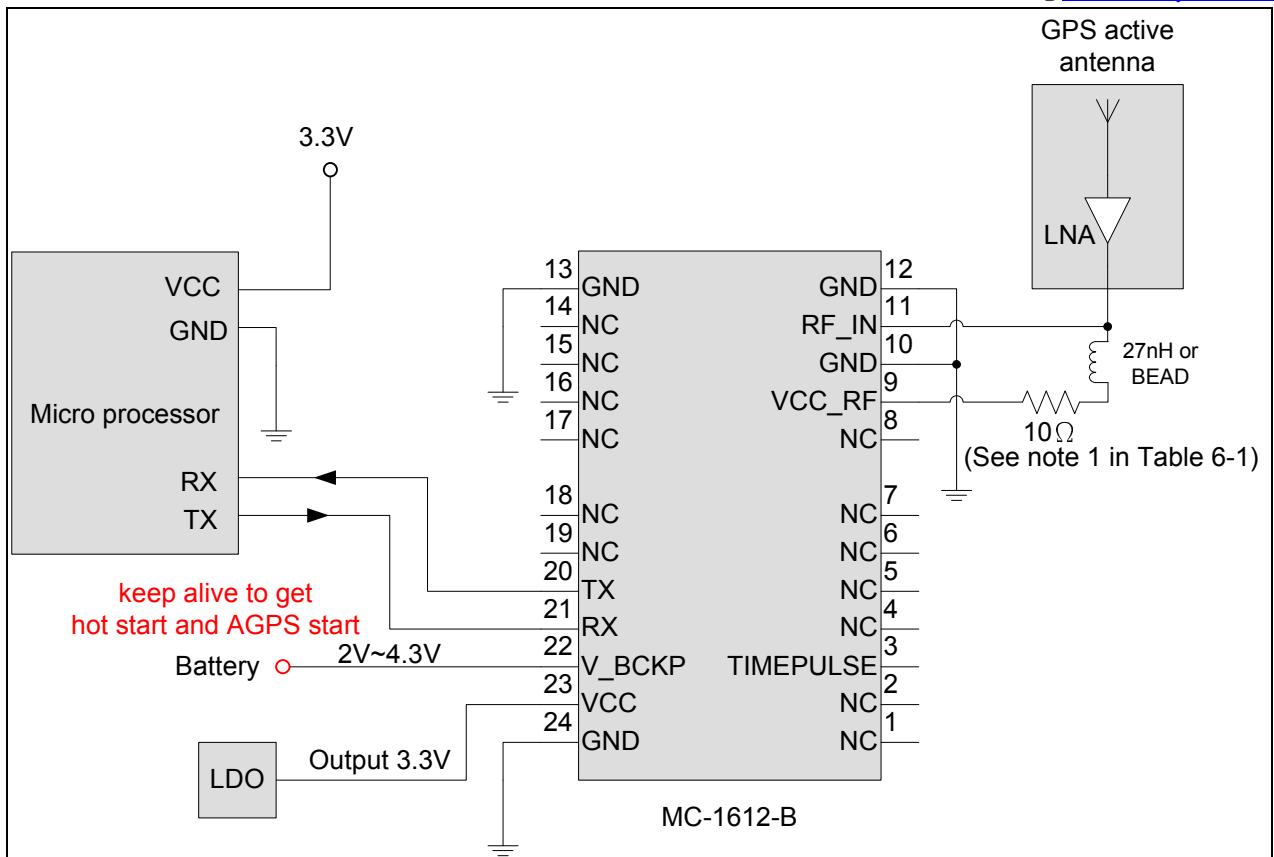
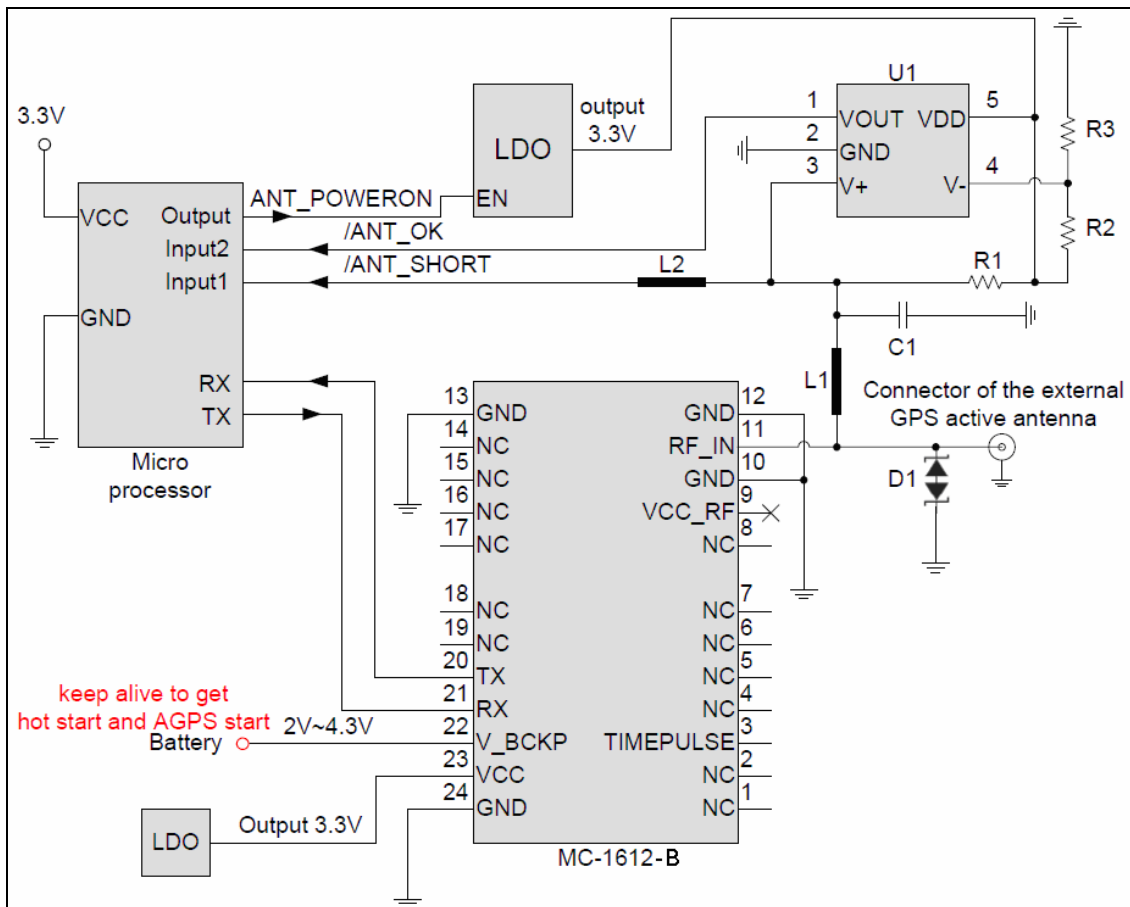

Fig 3-3 Typical application circuit that uses an active antenna.



keep alive to get
hot start and AGPS start
Battery 2V~4.3V

Logic table			
/ANT_SHORT	/ANT_OK	Status of the external GPS active antenna	Description
LOW	X	Short	Antenna is short.
HIGH	LOW	OK	Antenna is properly connected.
HIGH	HIHG	Open	Antenna is not connected

Reference BOM			
Part	Spec/value	Vendor	Remark
C1	18pF±5%, size 0402/0603		
D1	SUC0402-240E0R05P-LF	SFI	Input capacitance ≤ 0.5pF
L1	BEAD, 300R, size 0603 PB16080T-301Y-N	YAGEO	Must use 0603 size or larger
L2	BEAD, 300R, size 0402/0603		
R1	10R±5%, size 0603		Must use 0603 size or larger
R2	1K±5%, size 0402/0603		
R3	100K±5%, size 0402/0603		
U1	MCP6001T-IOT	Microchip	
	SGM8541XN5/TR	SG Micro	

Fig 3-4 Typical application circuit that has supervisor of the external active antenna.

4 GNSS receiver

Chip	MediaTek MT3333	
Frequency	GPS, GALILEO, QZSS: L1 1575.42MHz, C/A code BEIDOU: B1 1561.098MHz, C code	
Channels	Support 99 channels (33 Tracking, 99 Acquisition)	
Update rate	1Hz default, up to 10Hz	
Sensitivity	Tracking	-162dBm, up to -165dBm (with external LNA)
	Cold start	-143.5dBm, up to -148dBm (with external LNA)
Acquisition Time	Hot start (Open Sky)	1s (typical)
	Hot start (Indoor)	< 30s (typical)
	Cold Start (Open Sky)	33s (typical) without AGPS
< 15s (typical) with AGPS (hybrid ephemeris prediction)		
Position Accuracy	Autonomous	2.5m CEP
	SBAS	2.5m (depends on accuracy of correction data).
Max. Altitude	< 18,000 m, up to 50,000m by request	
Max. Velocity	< 515 m/s	
Protocol Support	NMEA 0183 ver 4.10	9600 bps ⁽¹⁾ , 8 data bits, no parity, 1 stop bits (default)
		1Hz: GGA, GLL, GSA, GSV, RMC, VTG

Note 1: Both baud rate and output message rate are configurable to be factory default.

5 Software interface

5.1 NMEA output message

Table 5.1-1 NMEA output message

NMEA record	Description
GGA	Global positioning system fixed data
GLL	Geographic position - latitude/longitude
GSA	GNSS DOP and active satellites
GSV	GNSS satellites in view
RMC	Recommended minimum specific GNSS data
VTG	Course over ground and ground speed

● GGA--- Global Positioning System Fixed Data

Table 5.1-2 contains the values for the following example:

\$GNGGA,054506.000,2503.7191,N,12138.7473,E,2,18,0.66,126.1,M,15.3,M,0.000,0.000*7D

Table 5.1-2 GGA Data Format

Name	Example	Units	Description
------	---------	-------	-------------

Message ID	\$GNGGA		GGA protocol header (GNGGA, GPGGA or BDGGA)
UTC Time	054506.000		hhmmss.sss
Latitude	2503.7191		ddmm.mmmm
N/S indicator	N		N=north or S=south
Longitude	12138.7473		dddmm.mmmm
E/W Indicator	E		E=east or W=west
Position Fix Indicator	2		See Table 5.1-3
Satellites Used	18		Range 0 to 33
HDOP	0.66		Horizontal Dilution of Precision
MSL Altitude	126.1	meters	
Units	M	meters	
Geoid Separation	15.3	meters	
Units	M	meters	
Age of Diff. Corr.	0000	second	Null fields when DGPS is not used
Diff. Ref. Station ID	0000		
Checksum	*7D		
<CR> <LF>			End of message termination

Table 5.1-3 Position Fix Indicators

Value	Description
0	Fix not available or invalid
1	GPS SPS Mode, fix valid
2	Differential GPS, SPS Mode, fix valid
3-5	Not supported
6	Dead Reckoning Mode, fix valid

● GLL--- Geographic Position – Latitude/Longitude

Table 5.1-4 contains the values for the following example:

\$GNGLL,2503.7191,N,12138.7473,E,054506.000,A,D*44

Table 5.1-4 GLL Data Format

Name	Example	Units	Description
Message ID	\$GNGLL		GLL protocol header (GNGLL, GPGLL or BDGLL)
Latitude	2503.7191		ddmm.mmmm
N/S indicator	N		N=north or S=south
Longitude	12138.7473		dddmm.mmmm
E/W indicator	E		E=east or W=west
UTC Time	054506.000		hhmmss.sss

Status	A		A=data valid or V=data not valid
Mode	D		A=autonomous, D=DGPS, E=DR, N=Data not valid, R=Coarse Position, S=Simulator
Checksum	*44		
<CR> <LF>			End of message termination

● GSA---GNSS DOP and Active Satellites

Table 5.1-5 contains the values for the following example:

\$GPGSA,A,3,23,28,05,193,17,13,10,04,12,02,20,,0.94,0.66,0.67*39

\$BDGSA,A,3,06,09,08,13,01,04,03,,,,,0.94,0.66,0.67*1C

Table 5.1-5 GSA Data Format

Name	Example	Units	Description
Message ID	\$GPGSA		GSA protocol header (GPGSA and BDGSA)
Mode 1	A		See Table 5.1-6
Mode 2	3		See Table 5.1-7
ID of satellite used	23		Sv on Channel 1
ID of satellite used	28		Sv on Channel 2
....		
ID of satellite used			Sv on Channel 12
PDOP	0.94		Position Dilution of Precision
HDOP	0.66		Horizontal Dilution of Precision
VDOP	0.67		Vertical Dilution of Precision
Checksum	*39		
<CR> <LF>			End of message termination

Table 5.1-6 Mode 1

Value	Description
M	Manual- forced to operate in 2D or 3D mode
A	Automatic-allowed to automatically switch 2D/3D

Table 5.1-7 Mode 2

Value	Description
1	Fix not available
2	2D
3	3D

● GSV---GNSS Satellites in View

Table 5.1-8 contains the values for the following example:

\$GPGSV,3,1,12,193,71,032,38,17,69,065,39,10,68,221,44,42,54,141,33*42

\$GPGSV,3,2,12,04,52,333,45,02,27,289,39,28,27,179,38,13,27,107,39*74
 \$GPGSV,3,3,12,23,23,074,37,05,14,221,40,20,14,042,34,12,11,319,34*71
 \$BDGSV,3,1,11,08,77,075,40,06,71,244,41,03,58,205,42,01,53,143,37*69
 \$BDGSV,3,2,11,09,48,228,42,04,38,119,37,02,35,243,34,13,30,040,42*65
 \$BDGSV,3,3,11,05,16,257,31,07,02,183,,10,01,207,*52

Table 5.1-8 GSV Data Format

Name	Example	Units	Description
Message ID	\$GPGSV		GSV protocol header (GPGSV and BDGSV)
Total number of messages ¹	3		Range 1 to 4
Message number ¹	1		Range 1 to 4
Satellites in view	12		
Satellite ID ²	193		Channel 1 (Range 01 to 196)
Elevation	71	degrees	Channel 1 (Range 00 to 90)
Azimuth	032	degrees	Channel 1 (Range 000 to 359)
SNR (C/No)	38	dB-Hz	Channel 1 (Range 00 to 99, null when not tracking)
....		
Satellite ID	13		Channel 4 (Range 01 to 196)
Elevation	27	degrees	Channel 4 (Range 00 to 90)
Azimuth	107	degrees	Channel 4 (Range 000 to 359)
SNR (C/No)	39	dB-Hz	Channel 4 (Range 00 to 99, null when not tracking)
Checksum	*74		
<CR> <LF>			End of message termination

1. Depending on the number of satellites tracked multiple messages of GSV data may be required.
2. GPS ID: 01~32, SBAS ID: 33~64, QZSS ID: 193~196, BEIDOU ID: 01~32

● RMC---Recommended Minimum Specific GNSS Data

Table 5.1-9 contains the values for the following example:

\$GNRMC,054506.000,A,2503.7191,N,12138.7473,E,0.05,329.80,181013,,D*7C

Table 5.1-9 RMC Data Format

Name	Example	Units	Description
Message ID	\$GNRMC		RMC protocol header (GNRMC, GPRMC or BDRMC)
UTC Time	054506.000		hhmmss.sss
Status	A		A=data valid or V=data not valid
Latitude	2503.7191		ddmm.mmmm
N/S Indicator	N		N=north or S=south
Longitude	12138.7473		dddmm.mmmm
E/W Indicator	E		E=east or W=west

Speed over ground	0.05	knots	True
Course over ground	329.80	degrees	
Date	181013		ddmmyy
Magnetic variation		degrees	
Variation sense			E=east or W=west (Not shown)
Mode	D		A=autonomous, D=DGPS, E=DR, N=Data not valid, R=Coarse Position, S=Simulator
Checksum	*7C		
<CR> <LF>			End of message termination

● VTG---Course Over Ground and Ground Speed

Table 5.1-10 contains the values for the following example:

\$GNVTG,329.80,T,,M,0.05,N,0.08,K,D*2B

Table 5.1-10 VTG Data Format

Name	Example	Units	Description
Message ID	\$GNVTG		VTG protocol header (GNVTG, GPVTG or BDVTG)
Course over ground	329.80	degrees	Measured heading
Reference	T		True
Course over ground		degrees	Measured heading
Reference	M		Magnetic
Speed over ground	0.05	knots	Measured speed
Units	N		Knots
Speed over ground	0.08	km/hr	Measured speed
Units	K		Kilometer per hour
Mode	D		A=autonomous, D=DGPS, E=DR, N=Data not valid, R=Coarse Position, S=Simulator
Checksum	*2B		
<CR> <LF>			End of message termination

5.2 Proprietary NMEA input/output message

Please refer to MTK proprietary message.

5.3 Examples to configure the power mode of GNSS module

The GNSS module supports different power modes that user can configure by issuing software commands.

5.3.1 Standby mode

User can issue software command to make GNSS module go into standby mode that

consumes less than 500uA current. GNSS module will be awaked when receiving any byte. The following flow chart is an example to make GNSS module go into standby mode and then wake up.

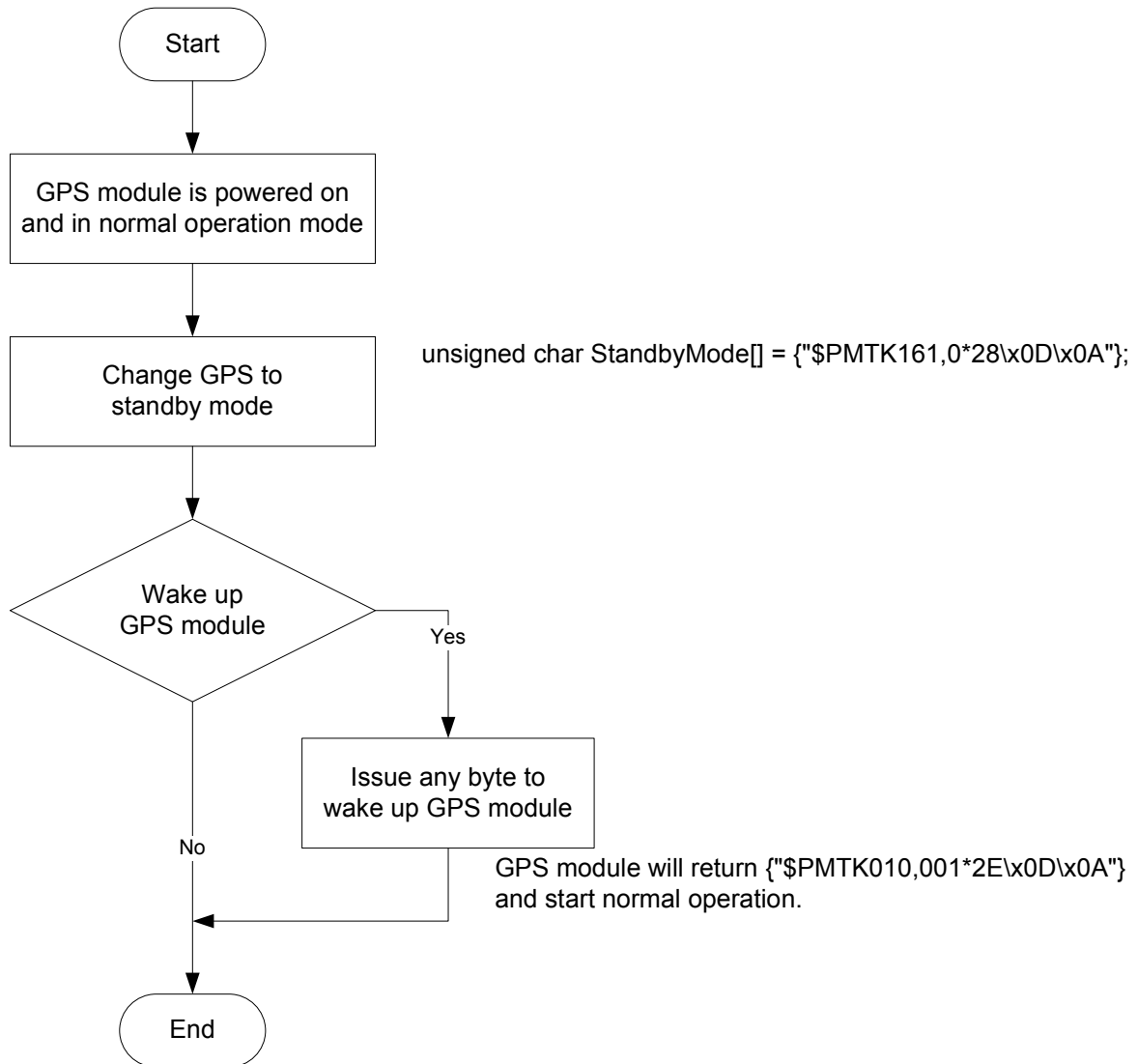

5.3.2 Periodic mode

When GNSS module is commanded to periodic mode, it will be in operation and standby periodically. Its status of power consumption is as below chart.

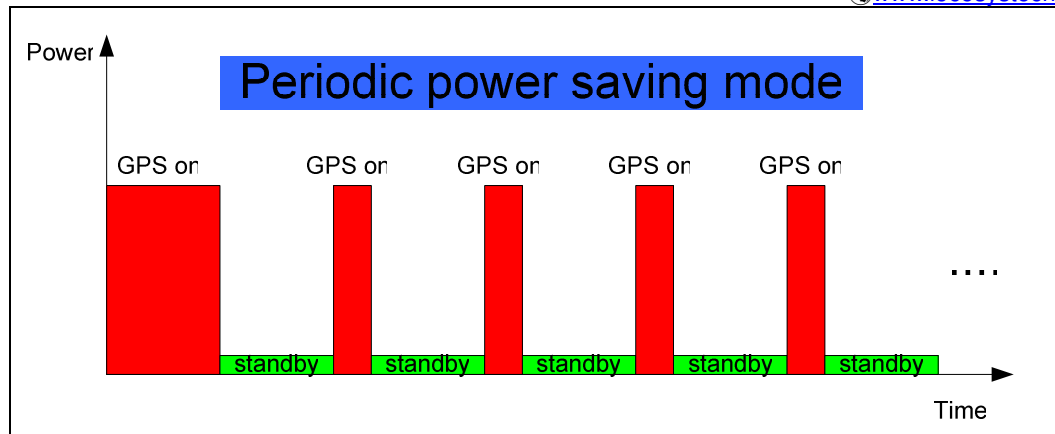

The following flow chart is an example to make GNSS module go into periodic mode and then back to normal operation mode.

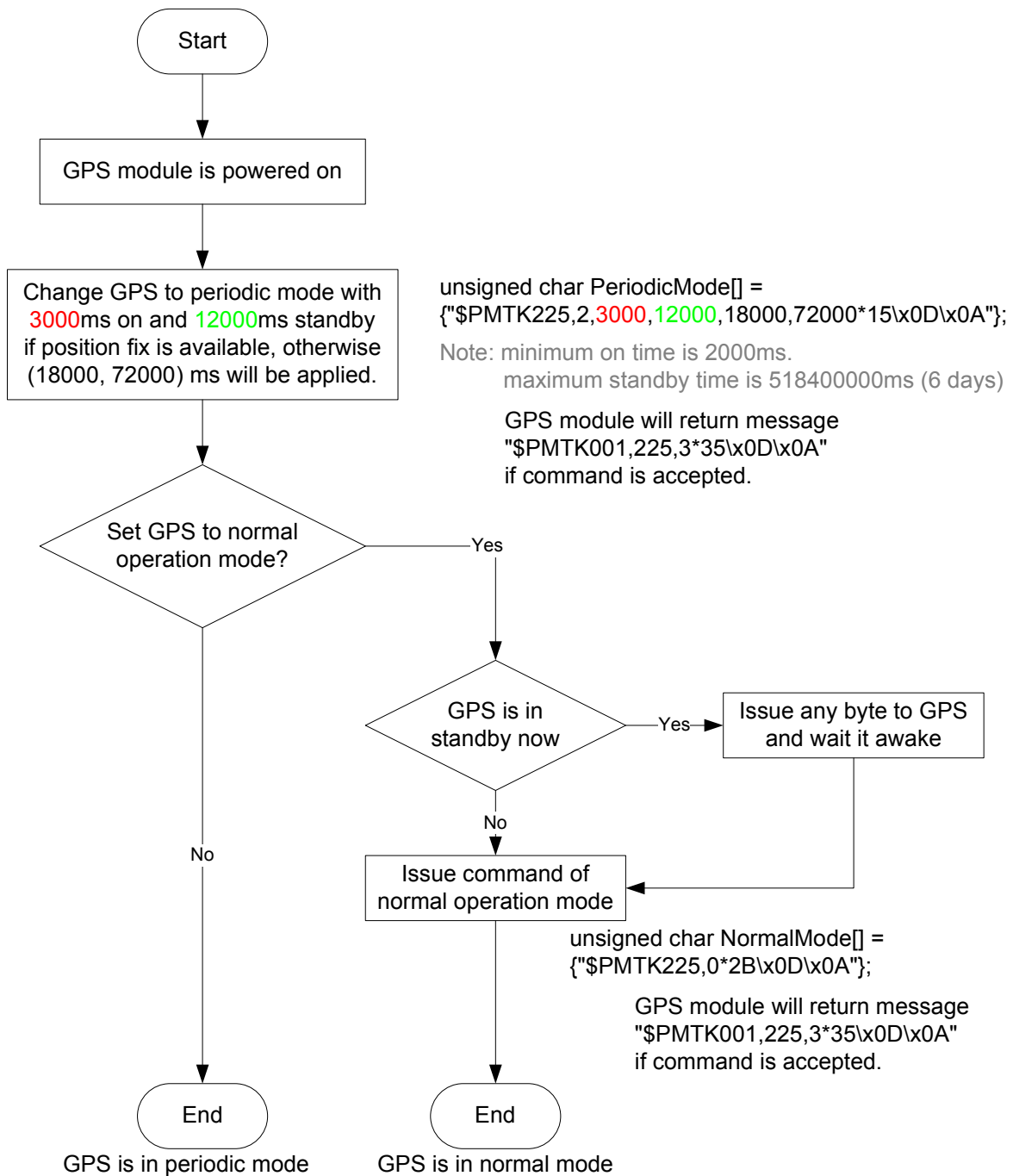

5.3.3 AlwaysLocate™ mode

AlwaysLocate™ is an intelligent controller of periodic mode. Depending on the environment and motion conditions, GNSS module can adaptively adjust working/standby time to achieve balance of positioning accuracy and power consumption. In this mode, the host CPU does not need to control GNSS module until the host CPU needs the GNSS position data. The following flow chart is an example to make GNSS module go into AlwaysLocate™ mode and then back to normal operation mode.

Note: AlwaysLocate™ is a trade mark of MTK.

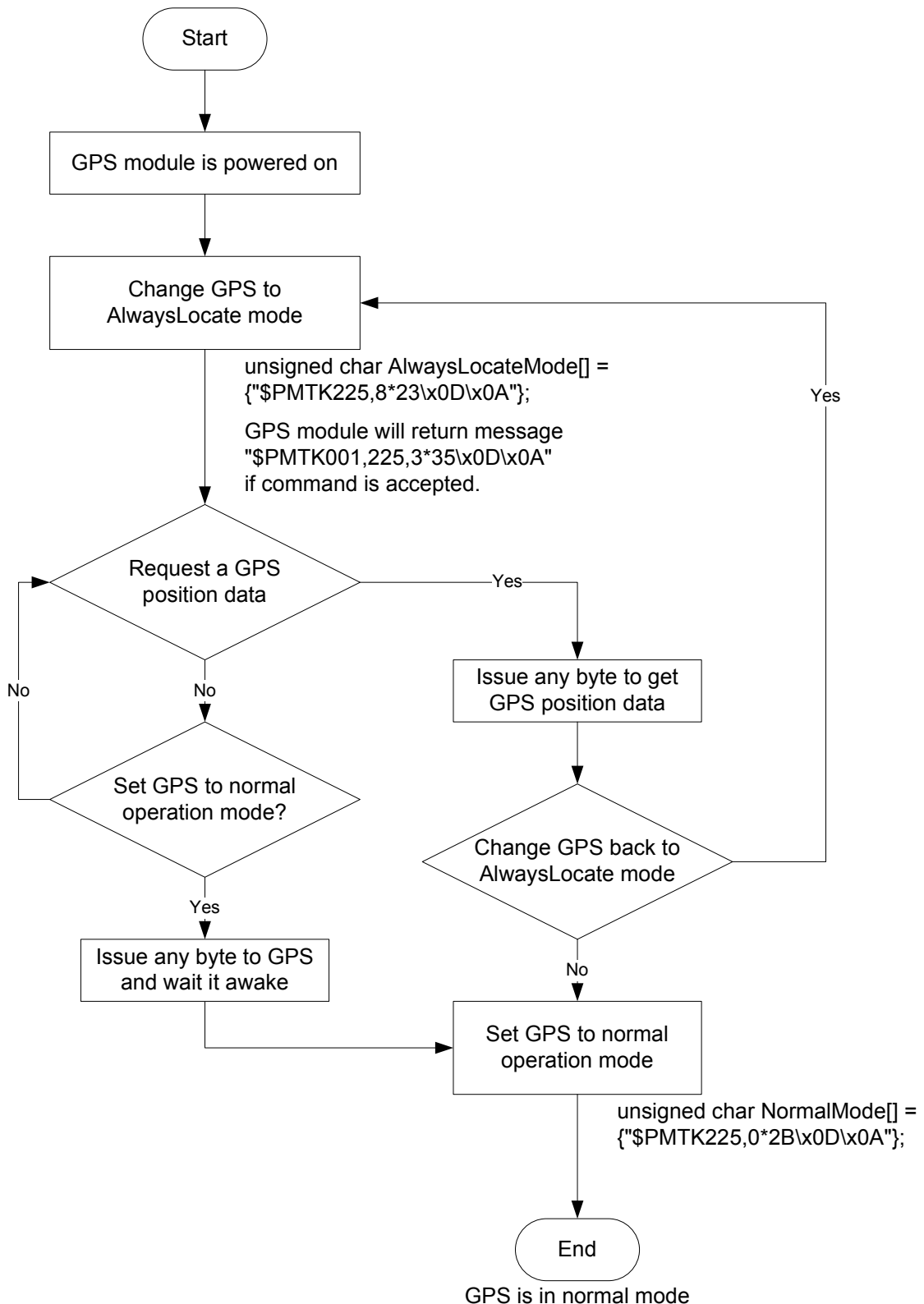

5.4 Data logger

The GNSS module has internal flash memory for logging GNSS data. The configurations include time interval, distance, speed, logging mode, and ... etc. For more information, please

contact us.

5.5 Examples to configure the update rate of GNSS module

The GNSS module supports up to 10Hz update rate that user can configure by issuing software commands. Note that the configurations by software commands are stored in the battery-backed SRAM that is powered through VBACKUP pin. Once it drains out, the default/factory settings will be applied.

Due to the transmitting capacity per second of the current baud rate, GNSS module has to be changed to higher baud rate for high update rate of position fix. The user can use the following software commands to change baud rate.

Baud rate	Software command
Factory default	\$PMTK251,0*28<CR><LF>
4800	\$PMTK251,4800*14<CR><LF>
9600	\$PMTK251,9600*17<CR><LF>
19200	\$PMTK251,19200*22<CR><LF>
38400	\$PMTK251,38400*27<CR><LF>
57600	\$PMTK251,57600*2C<CR><LF>
115200	\$PMTK251,115200*1F<CR><LF>

Note: <CR> means Carriage Return, i.e. 0x0D in hexadecimal. <LF> means Line Feed, i.e. 0x0A in hexadecimal.

If the user does not want to change baud rate, you can reduce the output NMEA sentences by the following software commands.

NMEA sentence	Software command
Factory default	\$PMTK314,-1*04<CR><LF>
Only GLL at 1Hz	\$PMTK314,1,0,0,0,0,0,0,0,0,0,0,0,0,0,0,0,0,0,0,0*29<CR><LF>
Only RMC at 1Hz	\$PMTK314,0,1,0,0,0,0,0,0,0,0,0,0,0,0,0,0,0,0,0,0*29<CR><LF>
Only VTG at 1Hz	\$PMTK314,0,0,1,0,0,0,0,0,0,0,0,0,0,0,0,0,0,0,0,0*29<CR><LF>
Only GGA at 1Hz	\$PMTK314,0,0,0,1,0,0,0,0,0,0,0,0,0,0,0,0,0,0,0,0*29<CR><LF>
Only GSA at 1Hz	\$PMTK314,0,0,0,0,1,0,0,0,0,0,0,0,0,0,0,0,0,0,0,0*29<CR><LF>
Only GSV at 1Hz	\$PMTK314,0,0,0,0,0,1,0,0,0,0,0,0,0,0,0,0,0,0,0,0*29<CR><LF>
Only ZDA at 1Hz	\$PMTK314,0,0,0,0,0,0,0,0,0,0,0,0,0,0,0,0,0,0,0,1,0*29<CR><LF>
RMC, GGA, GSA at 1Hz and GSV at 0.2Hz	\$PMTK314,0,1,0,1,1,5,0,0,0,0,0,0,0,0,0,0,0,0,0,0*2C<CR><LF>
If the command is correct and executed, GNSS module will output message \$PMTK001,314,3*36<CR><LF>	

After the GNSS module is changed to higher baud rate or reduced NMEA sentence, the user can configure it to high update rate of position fix by the following commands.

Interval of position fix	Software command
Every 100ms (10Hz) ⁽¹⁾	\$PMTK220,100*2F<CR><LF>
Every 200ms (5Hz)	\$PMTK220,200*2C<CR><LF>
Every 500ms (2Hz)	\$PMTK220,500*2B<CR><LF>
Every 1000ms (1Hz)	\$PMTK220,1000*1F<CR><LF>
Every 2000ms (0.5Hz) ⁽²⁾	\$PMTK220,2000*1C<CR><LF>
If the command is correct and executed, GNSS module will output message \$PMTK001,220,3*30<CR><LF>	

Note 1: The minimum interval of position fix is 100ms, i.e. the maximum update rate is 10Hz.

Note 2: The current consumption is the same with the update rate of 1Hz.

5.6 Configure the static navigation parameter

The output position of GNSS module will keep the same and output speed will be zero if the actual speed is below the threshold of the static navigation parameter. This is useful for different applications. For example, the car stopped at a red light will get stationary GNSS position if the threshold is 1.5m/s. It is better to disable this function by setting threshold to 0 for pedestrian navigation.

The format of the software command is as below.

\$PMTK386,speed threshold*checksum<CR><LF>

The unit of speed threshold is meter per second. The range of speed threshold is from 0.1m/s to 2.0m/s. Value 0 is to disable the function.

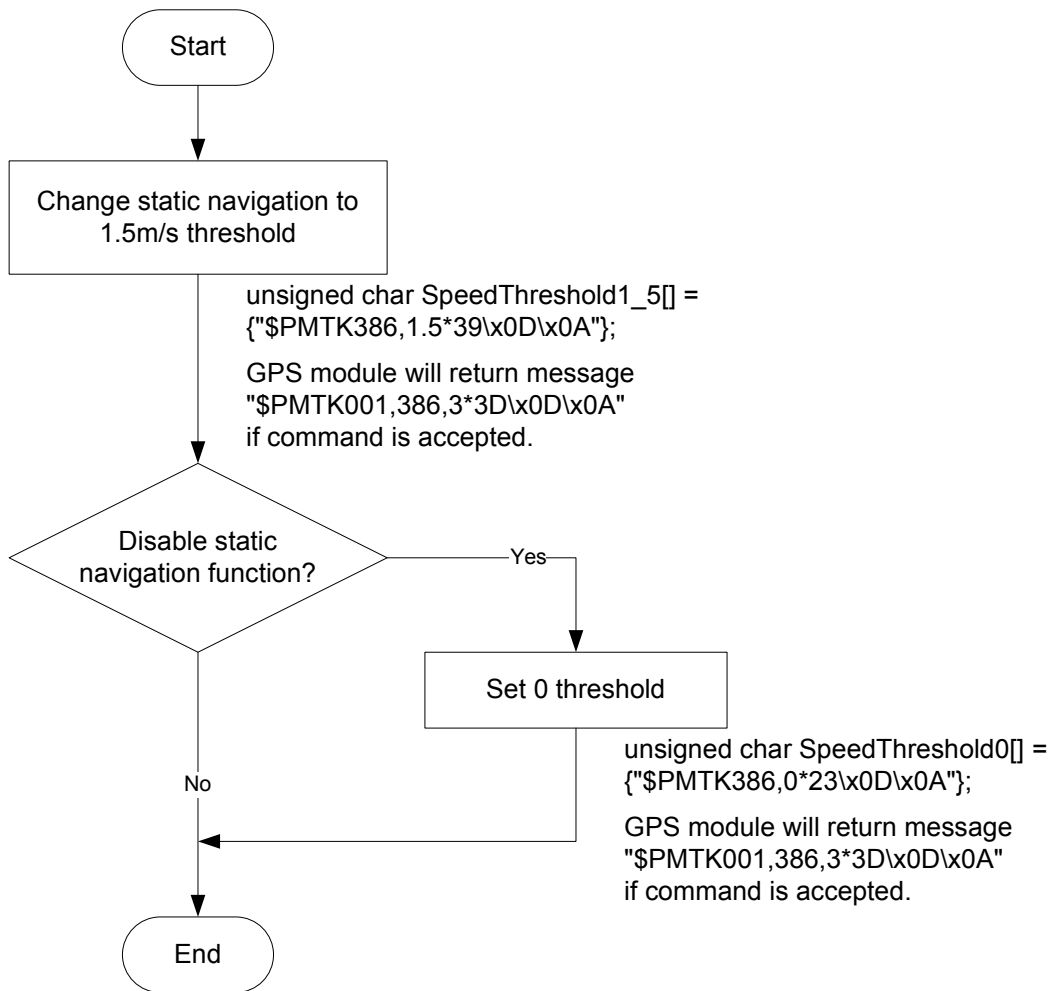

6 Pin assignment and descriptions

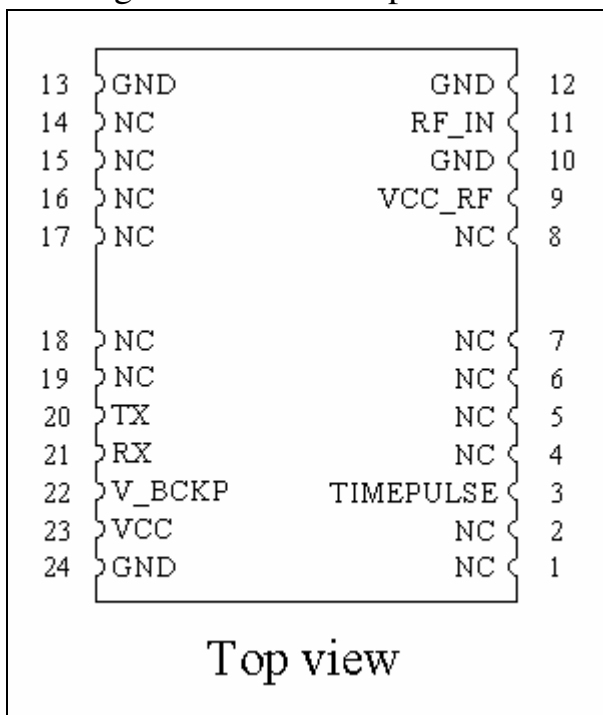

Table 6-1 Pin descriptions

Pin #	Name	Type	Description	Note
1	NC		Not connected	
2	NC		Not connected	
3	TIMEPULSE	O	Time pulse (1PPS, default 100 ms pulse/sec when 3D fix is available)	
4	NC		Not connected	
5	NC		Not connected	
6	NC		Not connected	
7	NC		Not connected	
8	NC		Not connected	
9	VCC_RF	O	Output voltage for active antenna	1
10	GND	P	Ground	
11	RF_IN	I	GNSS RF signal input	
12	GND	P	Ground	
13	GND	P	Ground	
14	NC		Not connected	
15	NC		Not connected	
16	NC		Not connected	
17	NC		Not connected	
18	NC		Not connected	
19	NC		Not connected	
20	TX	O	Serial output (Default NMEA)	
21	RX	I	Serial input (Default NMEA)	
22	V_BCKP	P	Backup battery supply voltage This pin must be powered to enable the module.	2
23	VCC	P	DC supply voltage	
24	GND	P	Ground	

<Note>

1. VCC_RF does not have short circuit protection.
2. In order to get the advantage of hybrid ephemeris prediction, this pin must be always powered during the period of effective ephemeris prediction.

7 DC & Temperature characteristics

7.1 Absolute maximum ratings

Parameter	Symbol	Ratings	Units
Input Voltage	VCC	4.3	V
Input Backup Battery Voltage	V_BCKP	4.3	V
Operating Temperature Range	Topr	-40 ~ 85	°C
Storage Temperature Range	Tstg	-40 ~ 85	°C

7.2 DC Electrical characteristics

Parameter	Symbol	Conditions	Min.	Typ.	Max.	Units
Input Voltage	VCC		3.0	3.3	4.3	V
Input Backup Battery Voltage	V_BCKP		2.0		4.3	V
VCC_RF Output Voltage	VCC_RF			VCC		V
Supply Current	Iss	VCC = 3.3V, w/o active antenna, Peak Acquisition Tracking Standby			200 ⁽¹⁾	mA
				40		mA
				25 ⁽²⁾		mA
				500		uA
Backup Battery Current	Ibat	VCC = 0V		7		uA
High Level Input Voltage	V _{IH}		2.0		3.6	V
Low Level Input Voltage	V _{IL}		-0.3		0.8	V
High Level Input Current	I _{IH}	no pull-up or down	-1		1	uA
Low Level Input Current	I _{IL}	no pull-up or down	-1		1	uA
High Level Output Voltage	V _{OH}		2.4		3.3	V
Low Level Output Voltage	V _{OL}				0.4	V
High Level Output Current	I _{OH}			2		mA
Low Level Output Current	I _{OL}			2		mA

Note 1. This happens when downloading AGPS data to MC-1612-B.

Note 2. Measured when position fix (1Hz) is available, input voltage is 3.3V and the function of self-generated ephemeris prediction is inactive.

7.3 Temperature characteristics

Parameter	Symbol	Min.	Typ.	Max.	Units
Operating Temperature	Topr	-40	-	85	°C
Storage Temperature	Tstg	-40	25	85	°C

8 Mechanical specification

8.1 Outline dimensions

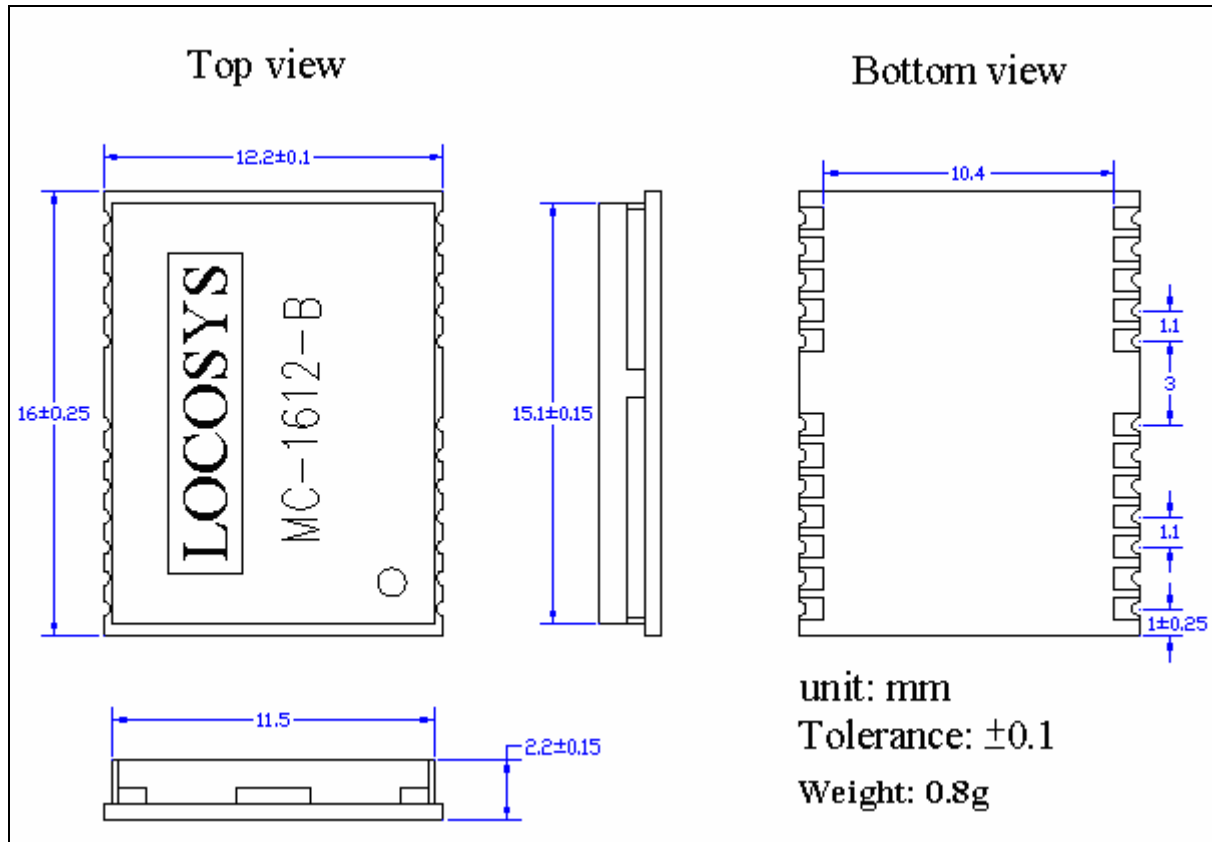

8.2 Recommended land pattern dimensions

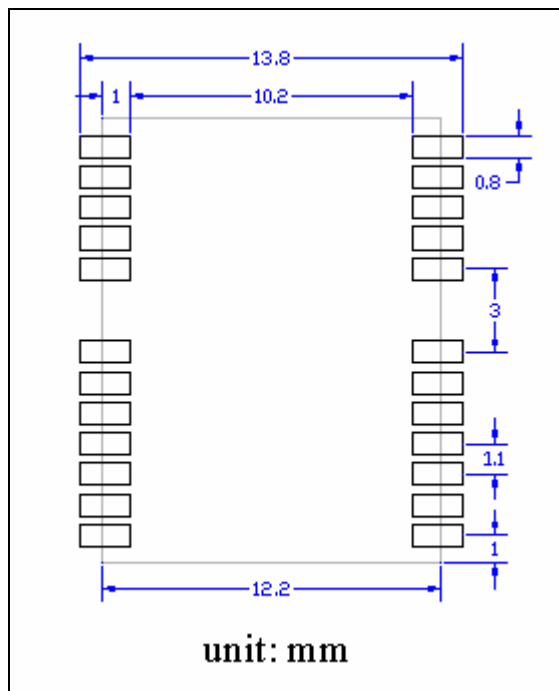

9 Reel Packing information

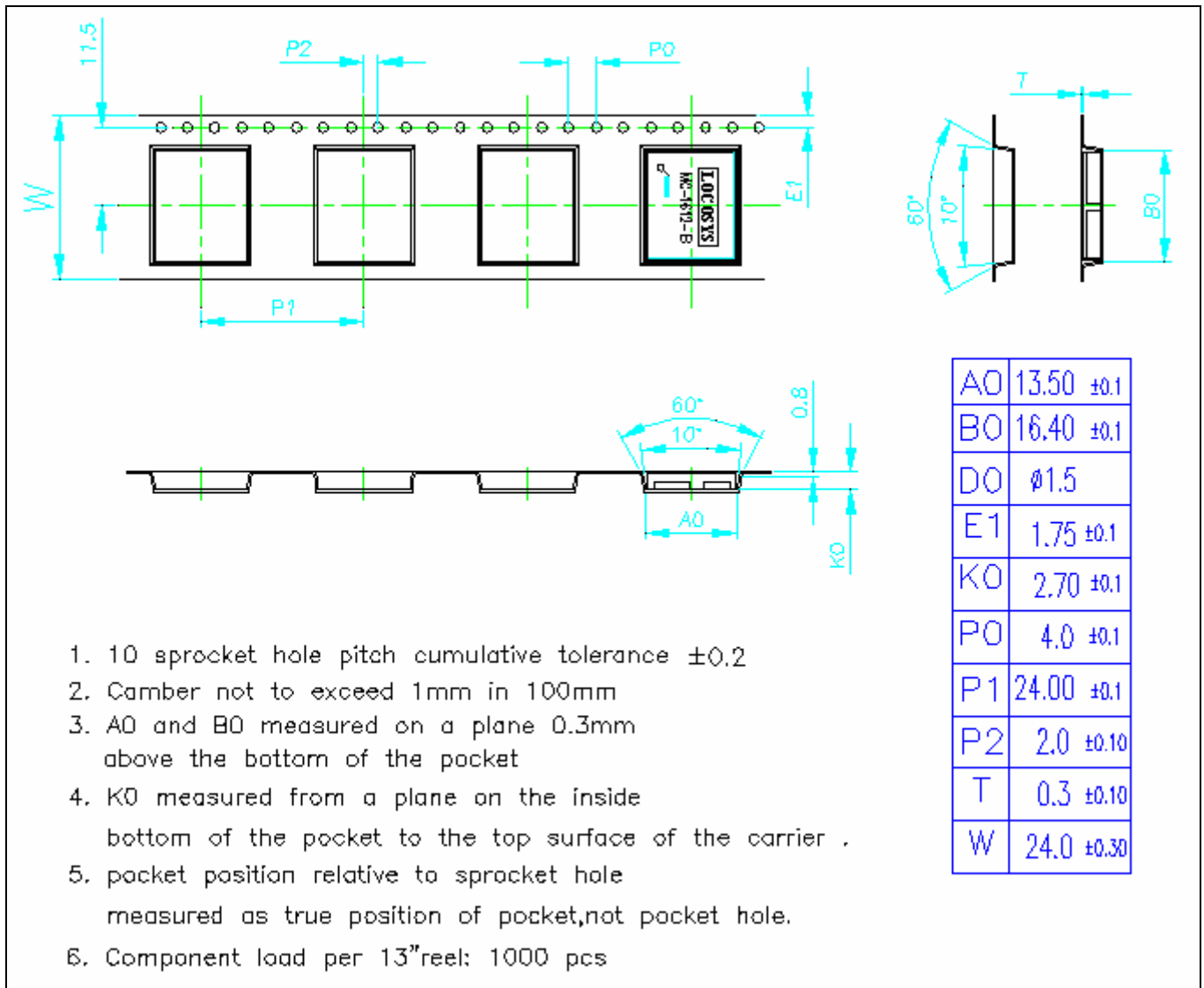

Document change list

Revision 1.0

- First release on December 26, 2013.