



# Datasheet of BK-1612-1N

---

Version 0.1

2024/5/16

LOCOSYS Technology Inc.

20F.-13, No.79, Sec. 1, Xintai 5th Rd.,

Xizhi District, New Taipei City 221, Taiwan

 886-2-8698-3698

 886-2-8698-3699

 [www.locosystech.com](http://www.locosystech.com)

## Contents

1. Introduction.....	3
2. Features .....	3
3. Applications .....	4
4. Functional Description .....	5
4.1 Key Features .....	5
4.2 Block Diagram .....	6
5. Pin Assignment and Definition .....	7
5.1 Pin Assignment .....	7
5.2 Pin Definition.....	7
6. DC Electrical Specification .....	9
7. UART Interface .....	10
8. Antenna Consideration .....	12
9. Power Supply Requirement .....	13
10. Backup Supply .....	13
11. 1pps Output.....	13
12. Layout Guidelines .....	14
13. ESD handling precautions .....	15
14. Mechanical Dimensions .....	16
15. Manufacturing, Packaging and Ordering Information.....	18
15.1 Assembly and Soldering.....	18
15.2 Moisture Sensitivity .....	18
15.3 Tape and Reel Packaging.....	19
16. Software Interface .....	20
16.1 NMEA output message.....	20
16.2 Proprietary NMEA output message .....	26
17. Document change list .....	28

## Table Index

Table 1: Key Features.....	5
Table 2: Pin Definition .....	7
Table 3: Operating Conditions.....	9
Table 4: Absolute Maximum Ratings .....	9
Table 5: ESD Endurance Table (Temperature: 25°C, Humidity: 45%) .....	15
Table 6: Reel Packaging .....	19
Table 7: NMEA output message .....	20
Table 8: GNSS system ID .....	22
Table 9: Proprietary NMEA output message .....	26

## Figure Index

Figure 1: Block Diagram.....	6
Figure 2: Pin Assignment .....	7
Figure 3: Serial Port connection .....	10
Figure 4: RS-232 Level Shift Circuit.....	11
Figure 5: Requires of Antenna Design.....	14
Figure 6: Top view Dimensions.....	16
Figure 7: Footprint of Recommendation.....	17
Figure 9: Tape and Reel Specifications .....	19
Figure 10: Packaging physical Figure .....	19



## 1. Introduction

The BK-1612-1N is a receiving module that supports dual-band and GPS, GLONASS & NavIC dual-mode. It has built-in highly integrated receiver chip, supports multi band and multi system cm4f (main frequency 350mhz, 22nm Technology) chip. Besides, it is capable of tracking all global civil navigation systems (GPS, GLONASS, NavIC ) in band L1 and L5.

BK-1612-1N module is based on the state of art NavIC architecture, integrating multi-band and multi-system GNSS RF and base band. This newly designed architecture makes this single chip achieve sub-meter level positioning accuracy without correction data from ground-based augmentation station and higher sensitivity, greater for improved jam resistance and multipath, provide a highly robust service in complicated environment.

BK-1612-1N module—featuring high sensitivity, low power consumption, and fast TTFF. The superior cold start sensitivity allows it to acquire, track, and get position fix autonomously in difficult weak signal environment. The receiver's superior tracking sensitivity allows continuous position coverage in nearly all outdoor application environments. The high performance signal parameter search engine is capable of testing 16 million time-frequency hypotheses per second, offering superior signal acquisition and TTFF speed.

## 2. Features

- Build on high performance
- Ultra high Track sensitivity: -165dBm
- Supports L1 GPS, GLONASS, and L5 NavIC signal reception
- Built in LNA and SAW Filter
- Up to 10 Hz update rate
- Extremely fast TTFF at low signal level
- Multipath detection and suppression

- Works with passive and active antenna
- Low power consumption: Max25mA@3.3V
- NMEA-0183 compliant protocol or custom protocol
- Operating voltage:2.7V to 3.6V
- SMD type with stamp holes
- Small form factor: 16×12.2×2.4mm
- Operating temperature -40 ~ +85°C
- RoHS compliant (Lead-free)

### 3. Applications

- LBS (Location Based Service)
- PND (Portable Navigation Device)
- Vehicle navigation system
- Mobile phone

## 4. Functional Description

### 4.1 Key Features

*Table 1: Key Features*

Parameter	Specification
GNSS engine	<ul style="list-style-type: none"> <li>• 200 tracking channels with fast search engine</li> </ul>
GNSS reception	<ul style="list-style-type: none"> <li>• GPS/QZSS : L1</li> <li>• GLONASS : L1</li> <li>• NavIC : L5</li> <li>• SBAS : GAGAN</li> </ul>
Update rate	<ul style="list-style-type: none"> <li>• GNSS : 1Hz (default) up to 10Hz</li> </ul>
Position accuracy	<ul style="list-style-type: none"> <li>• GNSS : 1.5m CEP</li> <li>• SBAS : 1.5m CEP</li> </ul>
Velocity & Time accuracy	<ul style="list-style-type: none"> <li>• GNSS : 0.01m/s CEP</li> <li>• SBAS : 0.05 m/s</li> <li>• 1PPS : 20 ns</li> </ul>
Time to First Fix (TTFF)	<ul style="list-style-type: none"> <li>• Hot start : 1 s</li> <li>• Cold start : 28 s</li> <li>• AGPS : 1.5 s</li> </ul>
Sensitivity	<ul style="list-style-type: none"> <li>• Cold start : -148dBm</li> <li>• Hot start : -165dBm</li> <li>• Reacquisition : -159dBm</li> <li>• Tracking &amp; navigation : -165dBm</li> </ul>
GNSS Operating limit	<ul style="list-style-type: none"> <li>• Velocity : 515m/s</li> <li>• Altitude : 18,000m</li> </ul>
Dynamics	<ul style="list-style-type: none"> <li>• 4G (39.2m/sec<sup>2</sup>) acceleration</li> </ul>
Datum	<ul style="list-style-type: none"> <li>• Default WGS-84, User definable</li> </ul>
UART Port	<ul style="list-style-type: none"> <li>• UART Port : TX and RX</li> <li>• Supports baud rate from 9600bps to 1000000bps (115200bps by default)</li> <li>• NMEA 0183 Protocol Ver. 4.00/4.10, BK GNSS Receiver Protocol</li> <li>• Supports batch data report mode</li> </ul>
Temperature Range	<ul style="list-style-type: none"> <li>• Normal operation : -40°C ~ +85°C</li> <li>• Storage temperature : -55°C ~ +100°C</li> <li>• Humidity : 5% ~ 95%</li> </ul>
Physical Characteristics	<ul style="list-style-type: none"> <li>• Size : 16±0.6×12.2±0.2×2.4±0.2mm</li> <li>• Weight : Approx. 0.9g</li> </ul>

## 4.2 Block Diagram

The BK-1612-1N is a high performance (GPS, GLONASS, NAVIC) in all bands (L1, L5). Satellite navigation receiver in a compact surface mount package. It is providing high performance signal acquisition and tracking. The simple UART serial interface and the standard NMEA-0183 protocol make usage of BK-1612-1N very easy and straightforward.

The BK-1612-1N module performs all the necessary system initialization, signal acquisition, signal tracking, data demodulation, and calculation of navigation solution autonomously.

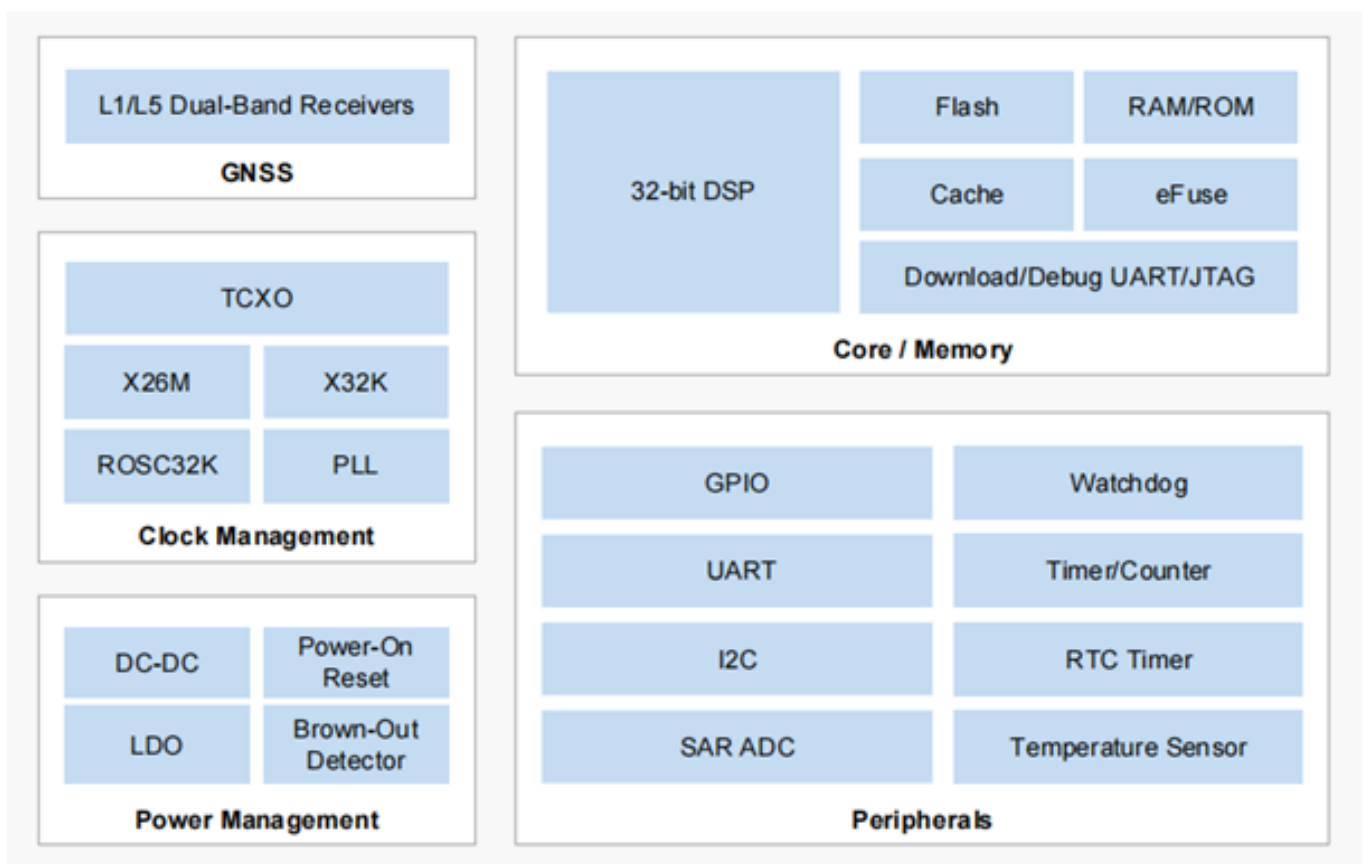

Figure 1: Block Diagram

## 5. Pin Assignment and Definition

The module is equipped with a 24-pin SMT pad that connects to your application platform. Sub-interfaces included in the pad are described in details in the following chapters.

### 5.1 Pin Assignment

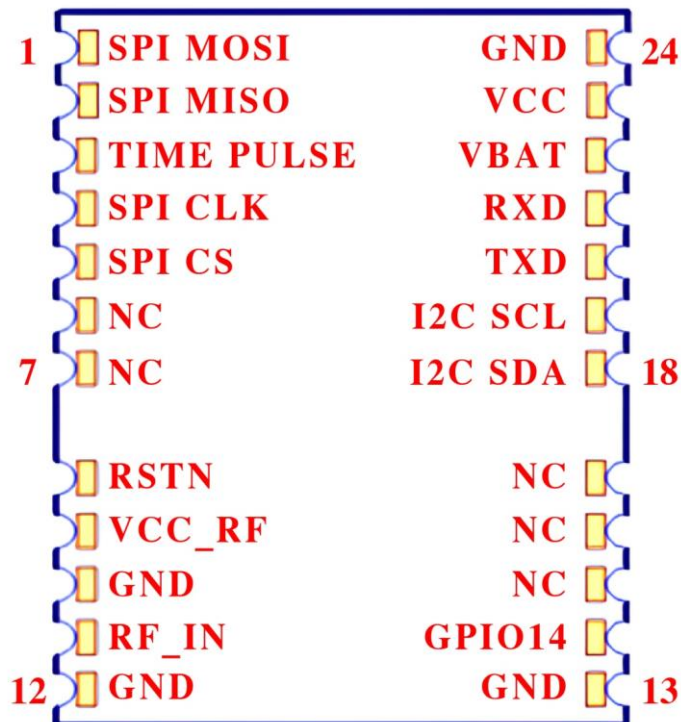

Figure 2: Pin Assignment

### 5.2 Pin Definition

Table 2: Pin Definition

Pin No.	Name	Description
1	SPI MOSI	Serial port SPI MOSI port, leave it vacant when not in use
2	SPI MISO	Serial port SPI MISO port, leave it vacant when not in use
3	TIME PULSE	PPS OUT PUT
4	SPI CLK	Serial port SPI CLK port, leave it vacant when not in use
5	SPI CS	Serial port SPI CS port, leave it vacant when not in use
6,7,15,16,17	NC	No connect



8	RSTN	RESET leave it vacant when not in use
9	VCC_RF	Active antenna power supply
10	GND	GND
11	RF_IN	RF input
12	GND	GND
13	GND	GND
14	GPIO14	JTAG_TDO, leave it vacant when not in use
18	I2C SDA	Serial port I2C SDA port, leave it vacant when not in use
19	I2C SCL	Serial port I2C SCL port, leave it vacant when not in use
20	TXD	Serial port TXD port
21	RXD	Serial port RXD port
22	VBAT	Backup battery : 2.8-3.3V, leave it vacant when not in use
23	VCC	Working voltage : 2.8-3.6V, Recommended use : 3.3V
24	GND	GND

## 6. DC Electrical Specification

Table 3: Operating Conditions

Parameter	Min	Typ	Max	Unit
Supply Voltage (VCC)	2.7	3.3	3.6	Volt
Acquisition Current (exclude active antenna current)		12		mA
Tracking Current (exclude active antenna current)		25		mA
<b>I/O port &amp;UART port working voltage</b>				
Output Low Voltage	-		0.4	Volt
Output HIGH Voltage	2.4		-	Volt
Input LOW Voltage	0.3		0.7	Volt
Input HIGH Voltage	2.1		4.2	Volt
Input LOW Current	-10		10	uA
Input HIGH Current	-10		10	uA
RF Input Impedance (RFIN)		50		Ohm

Table 4: Absolute Maximum Ratings

Parameter	Minimum	Maximum	Condition
Supply Voltage (VCC)	-0.5	3.6	Volt
Input Pin Voltage	-0.5	VCC+0.5	Volt
Input Power at RF_IN		+20	dBm
Storage Temperature	-55	+100	°C

## 7. UART Interface

The module provides one universal asynchronous receiver& transmitter serial port. The module is designed as DCE (Data Communication Equipment), following the traditional DCE-DTE (Data Terminal Equipment) connection. The module and the client (DTE) are connected through the signals shown in the following figure. It supports data baud-rate from 4800bps to 115200bps.

### UART port:

TXD: Send data to the RXD1 signal line of DTE.

RXD: Receive data from the TXD1 signal line of DTE.

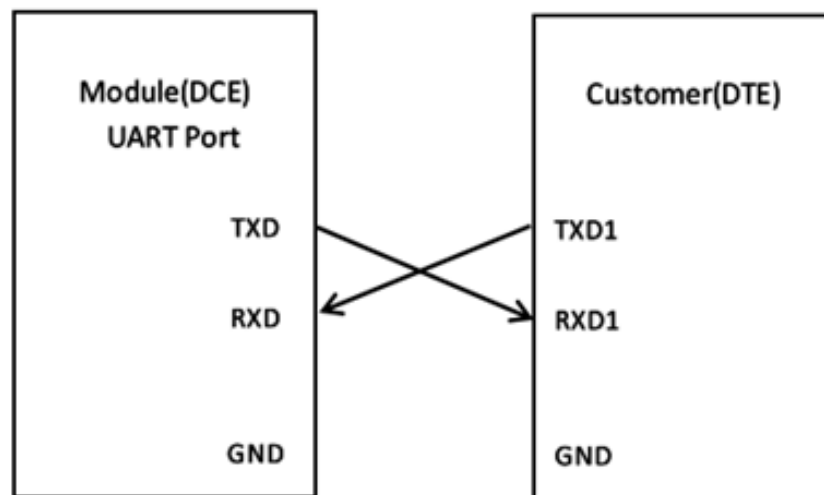

Figure 3: Serial Port connection

### This UART port has the following features:

- UART port can be used for NMEA Protocol output and proprietary commands input.
- The default output NMEA type setting is GGA, GSV, GSA, VTG, RMC, GLL, ZDA
- Proprietary message output PIRNSF, PGAMES
- UART port supports the following data rates:  
9600, 14400, 19200, 38400, 57600, 115200, 230400, 460800, 1000000 bps.  
115200bps by default, 8 bits, no parity bit, 1 stop bit.
- Hardware flow control and synchronous operation are not supported.

The UART port does not support the RS-232 level but only CMOS level. If the module's UART port is connected to the UART port of a computer, it is necessary to add a level shift circuit between the module and the computer. Please refer to the following figure.

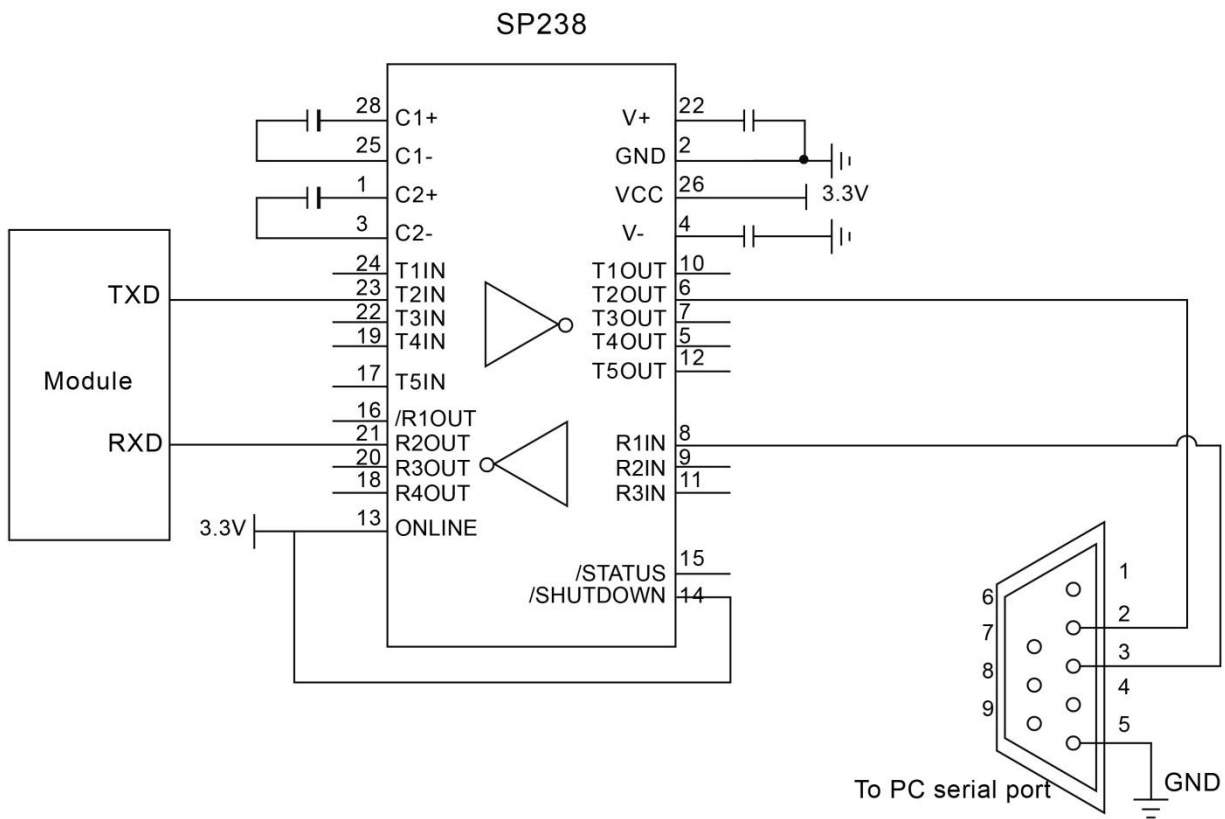

Figure 4: RS-232 Level Shift Circuit

## 8. Antenna Consideration

The BK-1612-1N is designed to use with active antenna, and passive antenna with higher antenna gain.

Passive ceramic patch antenna is low-cost and provides good sensitivity. 50-ohm output larger size ceramic patch antenna with higher antenna gain can be connected directly to RF input of the module. Usually the ceramic patch antenna and BK-1612-1N are mounted on opposite side of the PCB to reduce possibility of picking up digital noise. To improve signal reception performance, use larger ground plane under the patch antenna if possible; larger the ground plane, larger the overall antenna gain. The center frequency of the ceramic patch antenna changes with ground plane size. For optimal L1+L5 operation, frequency bandwidth of the antenna needs to cover 1174MHz ~ 1179MHz and 1573MHz ~ 1606MHz respectively when mounted on the PCB. It is usual to ask the ceramic patch antenna vendor to select or tune a patch antenna that best matches the customer PCB.

Active antenna is essentially a passive antenna with built-in LNA and a coaxial cable to connect the antenna to the module. It has the flexibility of being located remotely from the module, but requires antenna power. Active antenna usually costs more than passive patch antenna, but the performance in low signal environments is usually better. Active antenna with gain of 10 ~ 20dB and noise figure less than 1.5dB can be used with BK-1612-1N.

Antenna Type	Passive	Active
GPS Frequency (MHz)	1575.42 +/-2 (L1)	1575.42 +/-2 (L1)
NavIC Frequency (MHz)	1176.45 +/- 2 (L5)	1176.45 +/- 2 (L5)
VSWR	< 2 (typical)	< 2 (typical)
Polarization	RHCP	RHCP
Antenna Gain	> 0dBi	> -2dBi
LNA Gain		20dB (typical)
Noise Figure		< 1.5dB
Total Gain		> 18dBi

## 9. Power Supply Requirement

BK-1612-1N requires a stable power supply, to avoid ripple on VCC pin (<50mVpp). Power supply noise can affect the receiver's sensitivity. Bypass capacitors of 10uF and 0.1uF is recommended placing close to the module VCC pin; the values could be adjusted according to the amount and type of noise present on the supply line.

## 10. Backup Supply

The purpose of backup supply voltage pin (VBAT) is to keep the SRAM memory and the RTC powered when the module is powered down. This enables the module to have a faster time-to-first-fix when the module is powered on again. The backup current drain is less than 12μA. In normal powered on state, the internal processor access the SRAM and current drain is higher in active mode.

## 11. 1pps Output

When using four or more satellites for 3D positioning , the rising edge of the pulse generating 1 pulse per second on 1PPS pins is aligned with the UTC seconds , and the accuracy is about 12nS. When it is not positioned, it outputs a constant low pulse.

## 12. Layout Guidelines

### Separate RF and digital circuits into different PCB regions.

It is necessary to maintain 50-ohm impedance throughout the entire RF signal path. Try keeping the RF signal path as short as possible.

Do not route the RF signal line near noisy sources such as digital signals, oscillators, switching power supplies, or other RF transmitting circuit. Do not route the RF signal under or over any other components (including BK-1612-1N), or other signal traces. Do not route the RF signal path on an inner layer of a multi-layer PCB to minimize signal loss. Avoid sharp bends for RF signal path. Make two 45-deg bends or a circular bend instead of a single 90-degree bend if needed.

Avoid via hole with RF signal path whenever possible. Every via hole adds inductive impedance. Via holes are acceptable for connecting the RF grounds between different layers. Each of the module's ground pins should have a short trace tying immediately to the ground plane below through a via hole.

The bypass capacitors should be low ESR ceramic types and located directly adjacent to the pin they are for.

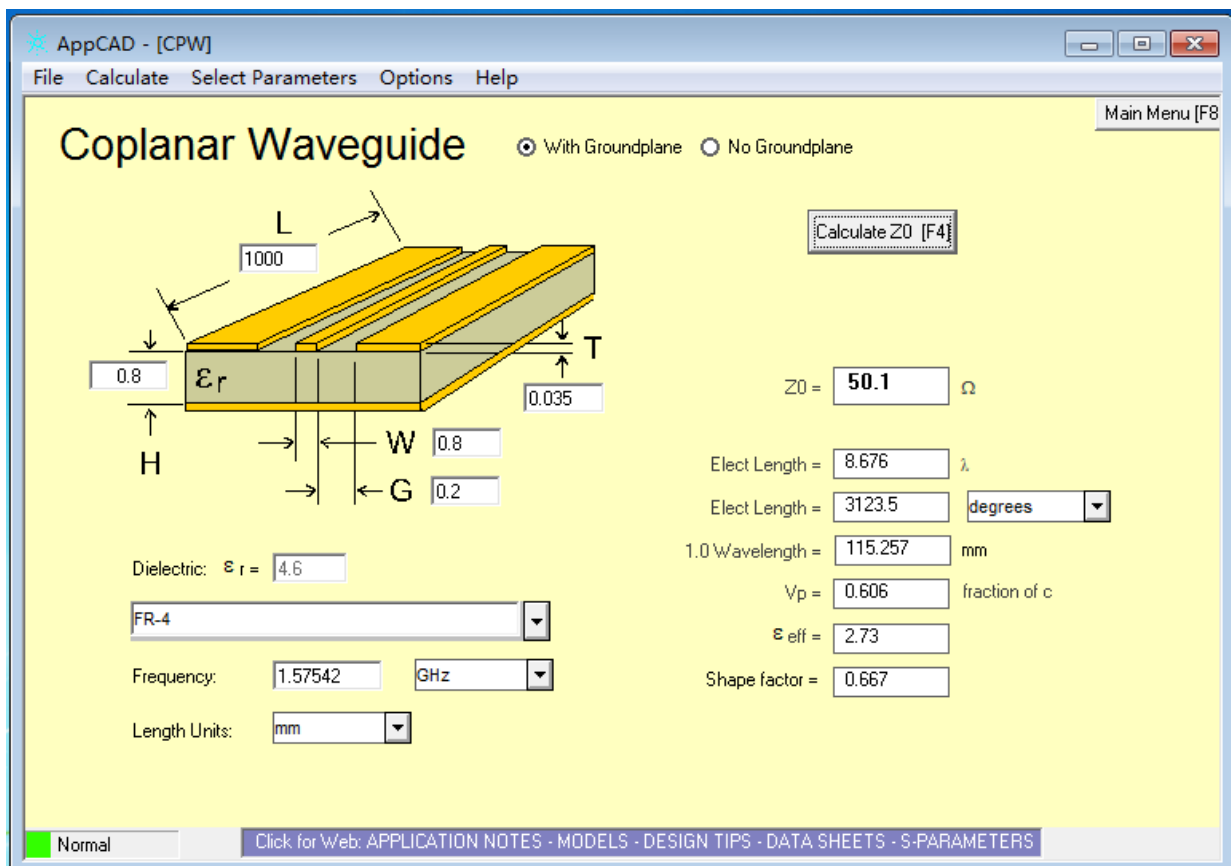

Figure 5: Requires of Antenna Design

### 13. ESD handling precautions

**BK-1612-1N module is an Electrostatic Sensitive Devices (ESD). Observe precautions for handling! Failure to observe these precautions can result in severe damage to the GPS receiver!**

GPS receivers are Electrostatic Sensitive Devices (ESD) and require special precautions when handling. Particular care must be exercised when handling patch antennas, due to the risk of electrostatic charges. In addition to standard ESD safety practices, the following measures should be taken into account whenever handling the receiver:

- ✧ Unless there is a galvanic coupling between the local GND (i.e. the work table) and the PCB GND, then the first point of contact when handling the PCB must always be between the local GND and PCB GND.
- ✧ Before mounting antenna patch, connect ground of the device  
When handling the RF pin, do not come into contact with any charged capacitors and be careful when contacting materials that can develop charges (e.g. patch antenna ~10pF, coax cable ~50-80pF/m, soldering iron.....)
- ✧ To prevent electrostatic discharge through the RF input, do not touch any exposed antenna area. If there is any risk that such exposed antenna area is touched in non ESD protected work area, implement proper ESD protection measures in the design.
- ✧ When soldering RF connectors and patch antennas to the receiver’s RF pin, make sure to use an ESD safe soldering iron (tip).



Table 5: ESD Endurance Table (Temperature: 25°C, Humidity: 45%)

Pin	Contact Discharge	Air Discharge
RF_IN	±5KV	±10KV
VCC	±5KV	±10KV
UART	±3KV	±6KV
Others	±2KV	±4KV



## 14. Mechanical Dimensions

This chapter describes the mechanical dimensions of the module.

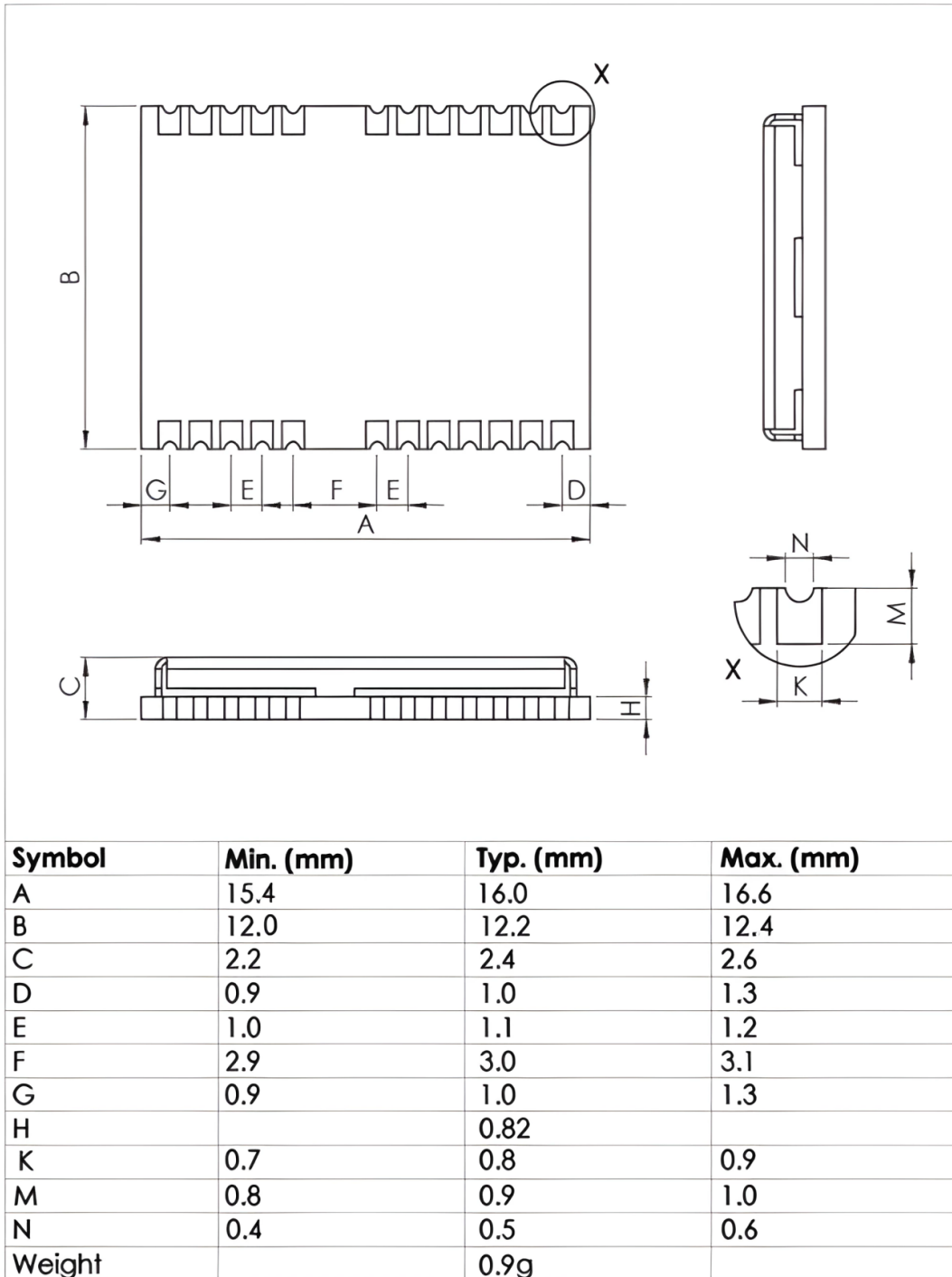

Figure 6: Top view Dimensions

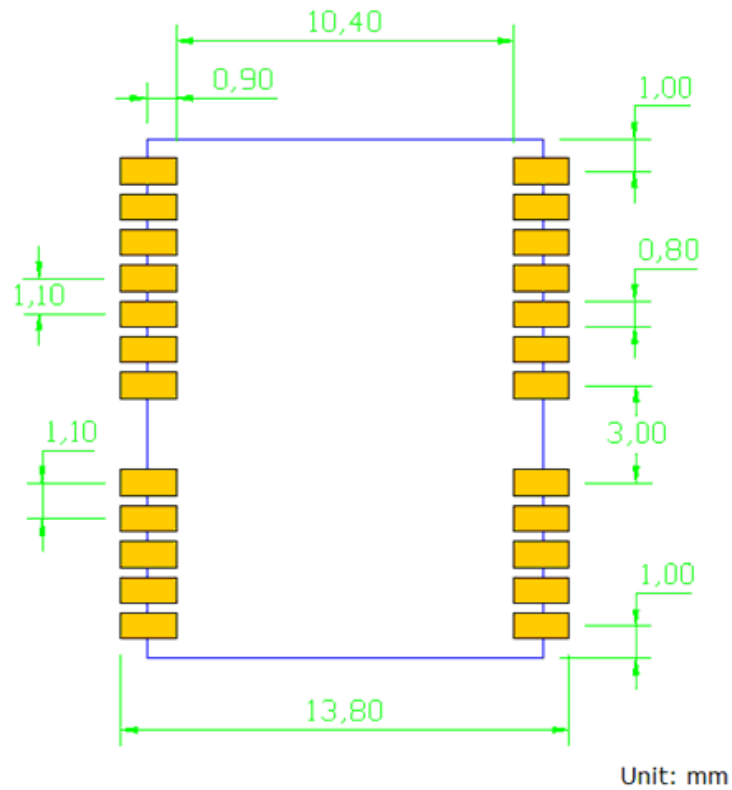

Figure 7: Footprint of Recommendation

**Note: The recommended land pattern dimensions are shown for reference only, as actual pad layouts may vary depending on application.**

## 15. Manufacturing, Packaging and Ordering Information

### 15.1 Assembly and Soldering

BK-1612-1N module is intended for SMT assembly and soldering in a Pb-free reflow process on the top side of the PCB. It is suggested that the minimum height of solder paste stencil is 100um to ensure sufficient solder volume. Pad openings of paste mask can be increased to ensure proper soldering and solder wetting over pads. It is suggested that the peak reflow temperature is 240°C (for Sn96.5Ag3.0Cu0.5 alloy). The absolute maximum reflow temperature is 260°C. To avoid damage to the module when it is repeatedly heated, it is suggested that the module should be mounted after reflow soldering for the other side of PCB has been completed. Recommended reflow soldering thermal profile is shown below:

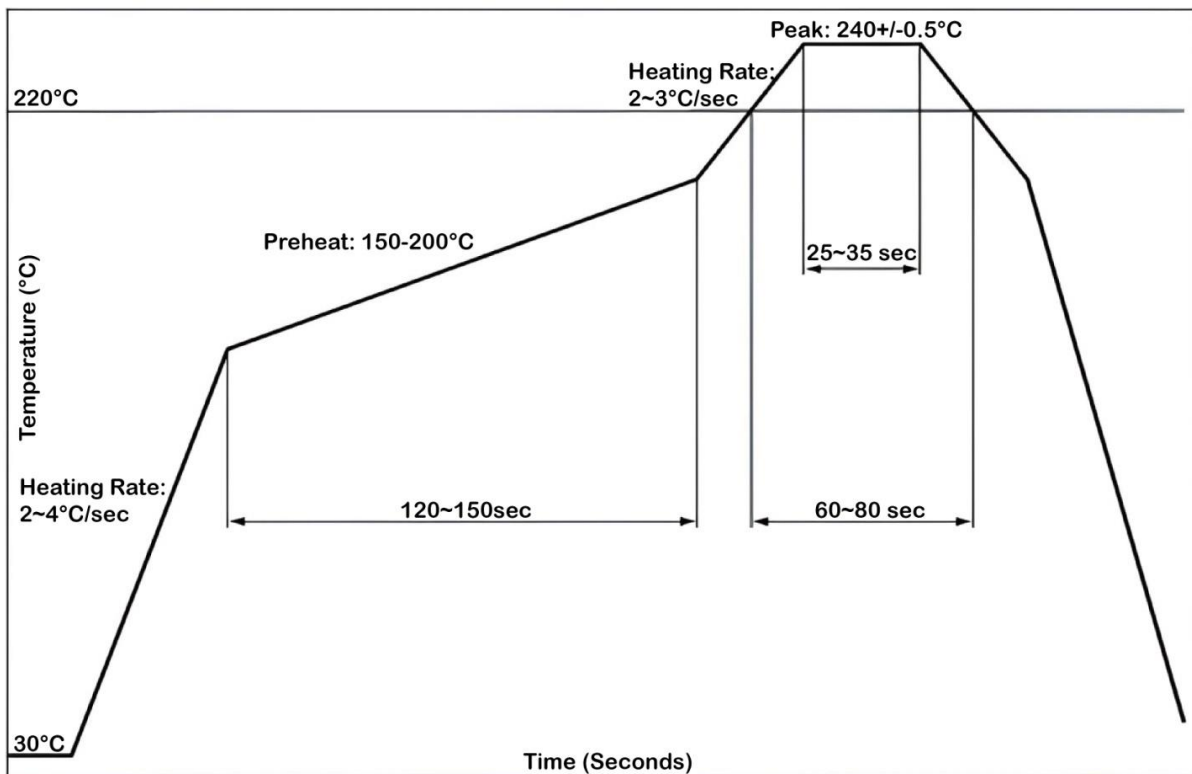

Figure 8: Recommended Reflow Soldering Thermal Profile

### 15.2 Moisture Sensitivity

BK-1612-1N module is sensitive to moisture, Level 3. To prevent BK-1612-1N from permanent damage during reflow soldering, baking before reflow soldering is required in following cases.

- ✧ Humidity indicator card: One or more indicating spots are no longer blue.
- ✧ The seal is opened and the module is exposed to excessive humidity.

BK-1612-1N shall be baked for 192 hours in a cryogenic environment at 40°C+5°C/-0°C and <5%RH, or for 24 hours in a high-temperature environment at 125°C±5°C.

As the plastic packaging tape is not heat-resistant, the module should be removed from the tape before baking, otherwise, the tape will be damaged due to high temperature heating, you can also refer to the actual production technology of the SMT factory.

### 15.3 Tape and Reel Packaging

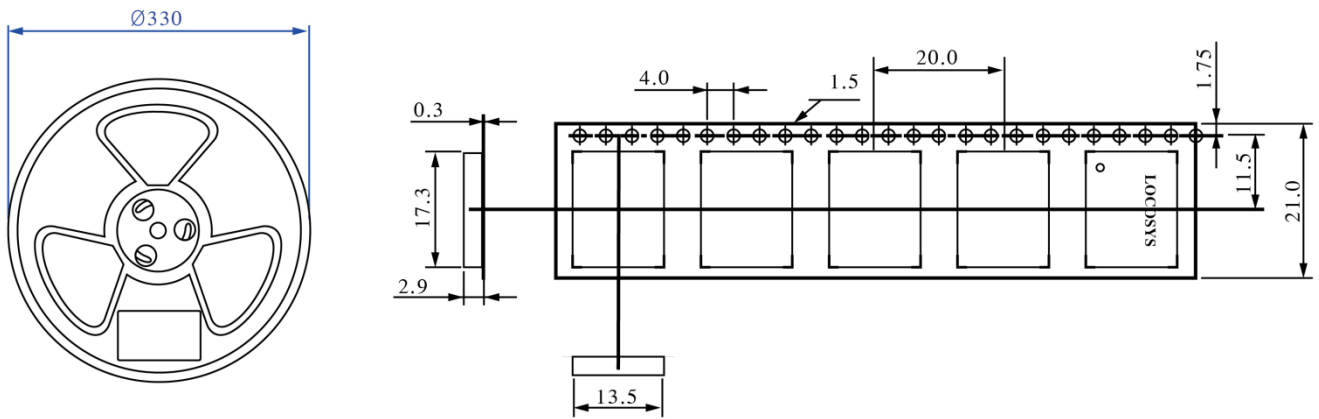

Figure 9: Tape and Reel Specifications



Figure 10: Packaging physical Figure

Table 6: Reel Packaging

Model Name	MOQ for MP	Minimum Package: 1000pcs
BK-1612-1N	1,000 pcs	Size: 365mm × 350mm × 53mm N.W: 0.90 kg G.W: 1.30 kg

## 16. Software Interface

### 16.1 NMEA output message

Table 7: NMEA output message

NMEA record	Description
GGA	Global Positioning System Fix Data
GSA	GNSS DOP and Active Satellites
GSV	GNSS Satellites in View
VTG	Course Over Ground and Ground Speed
RMC	Recommended Minimum Specific GNSS Data
GLL	Geographic position – Latitude / Longitude
ZDA	Time and Date

- **GGA – Global Positioning System Fix Data**

Contains the values for the following example:

```
$GNGGA,091030.000,2503.7169,N,12138.7580,E,1,26,0.6,140.321,M,0.000,M,,*70
```

Name	Example	Description
Message ID	\$GNGGA	GGA protocol header
UTC Time	091030.000	UTC of position in hhmmss.sss format, (000000.000 ~ 235959.999)
Latitude	2503.7169	Latitude in ddmm.mmmm format Leading zeros transmitted
N/S Indicator	N	Latitude hemisphere indicator, 'N' = North, 'S' = South
Longitude	12138.7580	Longitude in dddmm.mmmm format Leading zeros transmitted
E/W Indicator	E	Longitude hemisphere indicator, 'E' = East, 'W' = West
Quality Indicator	1	Quality Indicator 0: position fix unavailable 1: valid position fix, SPS mode 2: valid position fix, differential GPS mode
Satellites Used	26	Number of satellites in use, (00 ~ 56)
HDOP	0.6	Horizontal dilution of precision, (0.0 ~ 99.9)
Altitude	140.321	mean sea level (geoid)

Units	M	Units of antenna altitude, meters
Geoidal Separation	0.000	Geoidal separation in meters
Units	M	Units of geoidal separation, meters
Age of Differential GPS data		Age of Differential GPS data NULL when DGPS not used
DGPS Station ID		Differential reference station ID, 0000 ~ 1023
Checksum	70	

### ● GSA –GNSS DOP and Active Satellites

Contains the values for the following example:

```
$GNGSA,A,3,05,06,07,11,12,13,15,19,20,25,29,30,0.9,0.6,0.7,1*3D
```

```
$GNGSA,A,3,194,195,196,199,,,,,,,,,0.9,0.6,0.7,1*37
```

```
$GNGSA,A,3,66,86,65,88,87,71,72,,,,,,,,,0.9,0.6,0.7,2*3B
```

```
$GNGSA,A,3,02,03,09,10,,,,,,,,,0.9,0.6,0.7,5*34
```

Name	Example	Description
Message ID	\$GNGSA	GSA protocol header
Mode	A	Mode ‘M’ = Manual, forced to operate in 2D or 3D mode ‘A’ = Automatic, allowed to automatically switch 2D/3D
Mode	3	Fix type 1 = Fix not available 2 = 2D 3 = 3D
Satellite used 1~12	05,06,07,11, 12,13,15,19, 20,25,29,30	01 ~ 32 are for GPS 33 ~ 64 are for SBAS (PRN minus 87) 193~199 are for QZSS 65~ 96 are for GLONASS 01 ~ 07 are for NavIC
PDOP	0.9	Position dilution of precision (0.0 to 99.9)
HDOP	0.6	Horizontal dilution of precision (0.0 to 99.9)
VDOP	0.7	Vertical dilution of precision (0.0 to 99.9)
GNSS System ID	1	See below Table 8
Checksum	3D	

Table 8: GNSS system ID

Value	Description
1	GPS
2	GLONASS
5	IRNSS

### ● GSV – GNSS Satellites in View

Contains the values for the following example:

```
$GPGSV,5,1,18,05,50,321,34,06,28,108,34,07,10,061,27,11,59,070,39,1*69
$GPGSV,5,2,18,12,08,231,23,13,64,181,34,15,35,221,31,19,06,156,18,1*6B
$GPGSV,5,3,18,20,50,013,39,25,03,256,28,29,28,313,33,30,21,091,29,1*68
$GPGSV,5,4,18,194,17,171,32,195,72,106,36,196,75,062,38,199,60,167,33,1*6E
$GPGSV,5,5,18,40,00,000,28,41,00,000,32,,,,,,1*67
$GLGSV,2,1,08,66,03,223,29,86,45,125,38,65,46,246,36,88,17,332,28,1*70
$GLGSV,2,2,08,87,68,013,34,71,14,029,30,72,58,001,33,85,00,000,00,1*7B
$IRGSV,2,1,07,01,00,000,31,02,15,263,23,03,38,241,35,05,00,000,38,1*68
$IRGSV,2,2,07,07,00,000,40,09,10,249,30,10,56,164,39,,,,,1*53
```

Name	Example	Description
Message ID	\$GPGSV	GSV protocol header GP=GPS/QZSS, GL=GLONASS, IR=IRNSS
Number of message	5	Total number of GSV messages to be transmitted
Sequence number	1	Sequence number of current GSV message
Satellites in view	18	Total number of satellites in view
Satellite ID	05	01 ~ 32 are for GPS 33 ~ 64 are for SBAS (PRN minus 87) 193~199 are for QZSS 65~ 96 are for GLONASS 01 ~ 07 are for NavIC.
Elevation	50	Satellite elevation in degrees, (00 ~ 90)
Azimuth	321	Satellite azimuth angle in degrees, (000 ~ 359 )
SNR	34	C/No in dB (00 ~ 99) Null when not tracking
Signal ID	1	GPS/QZSS: L1 C/A=1 GLONASS: L1 C/A=1 IRNSS: L5=1
Checksum	69	

## ● VTG – Course Over Ground and Ground Speed

Contains the values for the following example:

```
$GNVTG,0.00,T,,M,0.00,N,0.00,K,A*23
```

Name	Example	Description
Message ID	\$GPVTG	VTG protocol header
Course over ground	0.00	Course over ground, degrees True
Reference	T	True
Course over ground		Course over ground, degrees Magnetic
Reference	M	Magnetic
Speed	0.00	Speed over ground in knots
Reference	N	Knots
Speed	0.00	Speed over ground in kilometers per hour
Reference	K	Kilometer per hour
Mode	A	Mode indicator ‘N’ = Data not valid ‘A’ = Autonomous mode ‘D’ = Differential mode
Checksum	23	

## ● RMC – Recommended Minimum Specific GNSS Data

Contains the values for the following example:

```
$GNRMC,071929.000,A,2240.7082,N,11402.7053,E,0.00,0.00,110524,,,A,V*03
```

Name	Example	Description
Message ID	\$GNRMC	RMC protocol header
UTC time	071929.000	UTC time in hhmmss.sss format (000000.00 ~ 235959.999)
Status	A	Status ‘V’ = Navigation receiver warning ‘A’ = Data Valid
Latitude	2240.7082	Latitude in ddmm.mmmm format Leading zeros transmitted
N/S indicator	N	Latitude hemisphere indicator ‘N’ =North ‘S’ = South
Longitude	11402.7053	Longitude in dddmm.mmmm format Leading zeros transmitted



E/W Indicator	E	Longitude hemisphere indicator 'E' = East 'W' = West
Speed over ground	0.00	Speed over ground in knots
Course over ground	0.00	Course over ground in degrees
UTC Date	110524	UTC date of position fix, ddmmyy format
Magnetic variation		degrees
Variation sense		
Mode indicator	A	Mode indicator 'N' = Data not valid 'A' = Autonomous mode 'D' = Differential mode
Navigational status indicator	V	S = Safe C = Caution U = Unsafe V = Void
Checksum	03	

● **GLL –Geographic position – Latitude / Longitude**

Contains the values for the following example:

\$GNGLL,2503.7153,N,12138.7593,E,091100.000,A,A\*4B

Name	Example	Description
Message ID	\$GNGLL	GLL protocol header
Latitude	2503.7153	Latitude in ddmn.mmmm format Leading zeros transmitted
N/S Indicator	N	Latitude hemisphere indicator 'N' = North 'S' = South
Longitude	12138.7593	Longitude in dddmm.mmmm format Leading zeros transmitted
E/W Indicator	E	Longitude hemisphere indicator 'E' = East 'W' = West
UTC Time	091100.000	UTC time in hhmmss.sss format (000000.000 ~ 235959.999)
Status	A	Status, 'A' = Data valid, 'V' = Data not valid

Mode Indicator	A	Mode indicator ‘N’ = Data not valid ‘A’ = Autonomous mode ‘D’ = Differential mode
Checksum	4B	

● ZDA – Time and Date

Contains the values for the following example:

\$GNZDA,071930.000,11,05,24,00,00\*47

Name	Example	Description
Message ID	\$GNZDA	ZDA protocol header
UTC time	071930.000	UTC time in hhmmss.ss format (000000.00 ~ 235959.99)
UTC Day	11	UTC time: day (01 ~ 31)
UTC Month	05	UTC time: month (01 ~ 12)
UTC Year	24	UTC time: year (2 last digit format)
Local zone hour	00	Local zone hours (00 ~ +/- 13)
one minutes	00	Local zone minutes (00 ~59)
Checksum	47	

## 16.2 Proprietary NMEA output message

Table 9: Proprietary NMEA output message

NMEA record	Description
\$PIRNSF	NavIC Sub-Frame Data (Periodic)
\$PGAMES	GAGAN Sub-Frame message type 63 data

- **\$PIRNSF – NavIC Sub-Frame Data (Periodic)**

Contains the values for the following example:

\$PIRNSF,3,1,8B,1F,AA,83,A2,17,54,18,09,9C,00,0B,D4,BF,40,05,E8,B8,F8,43,2D,E2,C5,7F,F4,00,0E,  
 D8,B2,BB,CB,9A,00,B2,12,D0,0\*0C

Name	Example	Description
Message ID	\$PIRNSF	\$PIRNSF protocol header
SVID	3	NAVIC Satellite PRN
SFID	1	Sub-frame ID (1-4)
SF_DATA	8B~D0	Decoded sub-frame data after preamble, begin with telemetry word (TLM).
SF_DATA	0	Decoded sub-frame data Tail bits.
Checksum	0C	

- **\$PGAMES – GAGA Sub-Frame message type 63 data**

Contains the values for the following example:

\$PGAMES,40,01,C0,00,04,28,63,A2,3C,00,08,50,00,00,00,00,00,00,00,00,00,00,00,00,00,00,00,00,00\*7E

\$PGAMES,41,01,C0,15,44,55,35,42,04,D4,55,35,34,14,74,50,00,00,00,00,00,00,00,00,00,00,00,00,00\*08

\$PGAMES,45,01,C0,15,44,55,35,42,04,D4,55,35,34,14,74,50,00,00,00,00,00,00,00,00,00,00,00,00,00\*0C

Name	Example	Description
Message ID	\$PGAMES	\$PGAMES protocol header
SVID	40	GAGAN PRN
Subframe data[0]	01	Type 63 message data bit 0~ bit 7 in UINT8 mapped to Subframe data[0] bit 7~ bit 0, bit 0 is LSB
Subframe data[ndx]		Type 63 message data bit 8~ bit 207 in UINT8 ndx: 1~25 bit 8 ~ bit 15 mapped to Subframe data[1] bit 7~ bit 0, bit 0 is LSB bit 16 ~ bit 23 mapped to Subframe data[2] bit 7~ bit 0, bit 0 is LSB ...etc

Subframe data[26]	00	Type 63 message data bit 208~ bit 211 mapped to Subframe data[26] bits 7~4 of UINT8 Padding 4 bits of zero at bits 3~0 of UINT8 Bit 0 is LSB
Checksum	7E	

Type 63 message data bit 0 ~ bit 21

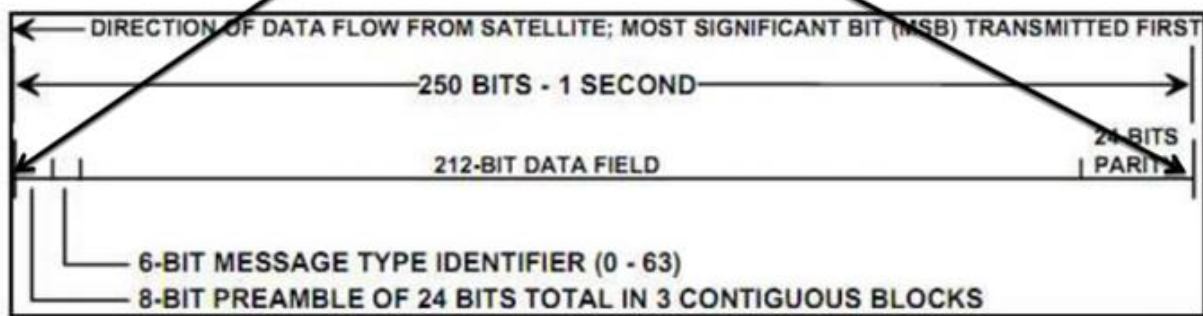

Data Type Definition

UINT8	8 bit unsigned integer
UINT16	16 bit unsigned integer
UINT32	32 bit unsigned integer
SINT8	8 bit signed integer
SINT16	16 bit signed integer
SINT32	32 bit signed integer
SPFP	32 bit single precision floating point number
DPFP	64 bit double precision floating point number

## 17. Document change list

### Revision 0.1

- Draft release on May 16, 2024.