



Datasheet of MG-1010-52Q

Vision 1.0

LOCOSYS Technology Inc.

20F.-13, No.79, Sec. 1, Xintai 5th Rd.,

Xizhi District, New Taipei City 221, Taiwan

 886-2-8698-3698

 886-2-8698-3699

 www.locosystech.com

Contents

1.	Introduction.....	3
2.	Features.....	3
3.	Application	4
4.	Reference circuit	4
5.	GNSS Performance	6
6.	Antenna Consideration	7
7.	Software interface	8
7.1	NMEA output message	8
7.2	Proprietary commands	14
7.3	Proprietary PLSC commands	29
8.	Pin assignment and descriptions	30
9.	DC & Temperature characteristics	32
10.	Mechanical specification	33
10.1	Outline dimensions	33
10.2	Recommended land pattern dimensions.....	34
11.	Reel Packing information	35
11.1	ESD precaution.....	35
11.2	Packaging	35
11.2.1	Packaging.....	35
11.2.2	Box packaging	36
11.3	Moisture sensitivity level	37
11.4	Reflow soldering.....	37
12.	Product marking and ordering information.....	38
12.1	Product marking	38
12.2	Ordering information	38
13.	Document change list	39

Table Index

Table 1: Module Key Features	6
Table 2: Recommended Antenna Setting	7
Table 3: NMEA output message	8
Table 4: GGA Data Format	8
Table 5: Position Fix Indicators.....	9
Table 6: GLL Data Format	9
Table 7: GSA Data Format.....	10
Table 8: Mode 1	10
Table 9: Mode 2.....	10
Table 10: GNSS system ID	10
Table 11: GSV Data Format	11
Table 12: RMC Data Format	12
Table 13: VTG Data Format.....	12
Table 14: GST Data Format	13
Table 15: PLSC commands	29
Table 16: Pin descriptions	30
Table 17: Module Power Supply Ratings.....	32
Table 18: DC Electrical characteristics	32
Table 19: Temperature characteristics.....	32
Table 20: Bottom Dimension (Unit: mm)	33
Table 21: Reel Packing	36
Table 22: Ordering information.....	38

Figure Index

Figure 1: Block Diagram.....	4
Figure 2: Typical application circuit that uses an active antenna	5
Figure 3: Typical interface of Passive antenna	5
Figure 4: Pin Assignment	30
Figure 5: Top View and Side View (Unit: mm).....	33
Figure 6: Footprint of Recommendation (Unit: mm)	34
Figure 7: Tape and Reel Specification	35
Figure 8: Packing method	36
Figure 9: Ramp-soak-spike-reflow of Furnace Temperature	37



1. Introduction

LOCOSYS MG-1010-52Q is high-performance GNSS positioning module that is capable of tracking all global civil navigation systems. It supports new GPS L1C and BEIDOU B1C signals. Based on the Airoha AG3352 platform, the MG-1010-52Q can concurrently receive and process signals from all constellations (GPS, GLONASS, BeiDou, Galileo and QZSS), which in combination with the support of SBAS greatly increases the number of visible satellites and enhances positioning accuracy.

MG-1010-52Q module is based on the state of ARM® Cortex®-M4 with Floating Unit and Memory Protection Unit to integrate single-band and multi-system GNSS RF band. This newly designed architecture makes this single chip achieve 1.5m CEP (open-sky) positioning accuracy representing a 40% improvement over previous generations of devices. The superior cold-start sensitivity allows it to acquire, track, and get position fix autonomously in difficult weak signal environment. Its superior tracking sensitivity allows continuous position coverage in nearly all outdoor application environments.

2. Features

- Support GPS, GLONASS, GALILEO, BEIDOU and QZSS
- Capable of SBAS (WAAS, EGNOS, MSAS, GAGAN) and QZSS SLAS
- Low power consumption
- Extremely fast TTFF at low signal level
- Up to 10 Hz update rate
- ±10ns high accuracy time pulse (PPS)
- Small form factor 10.1 x 9.7 x 2.0 mm
- SMD type with stamp holes; RoHS compliant

3. Application

- Personal positioning and navigation
- Drone (UAV application)
- Automotive navigation
- Wildlife and livestock tracking
- Marine navigation
- Portable tracker
- Weather balloon or sounding balloon

4. Reference circuit

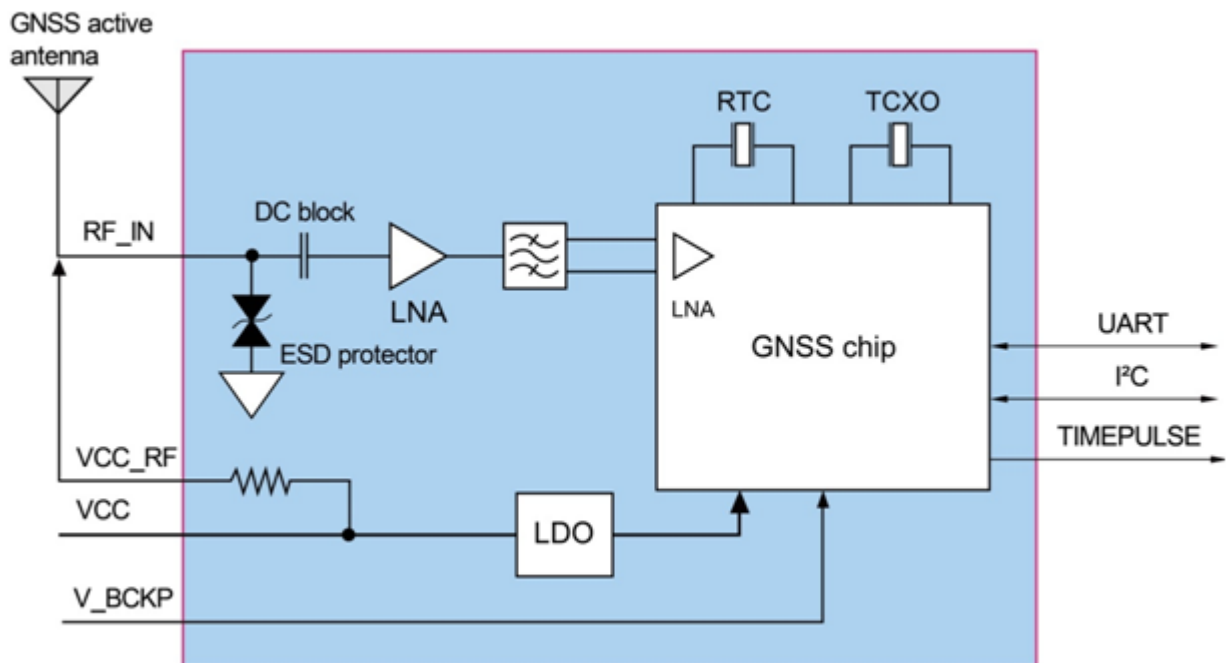

Figure 1: Block Diagram

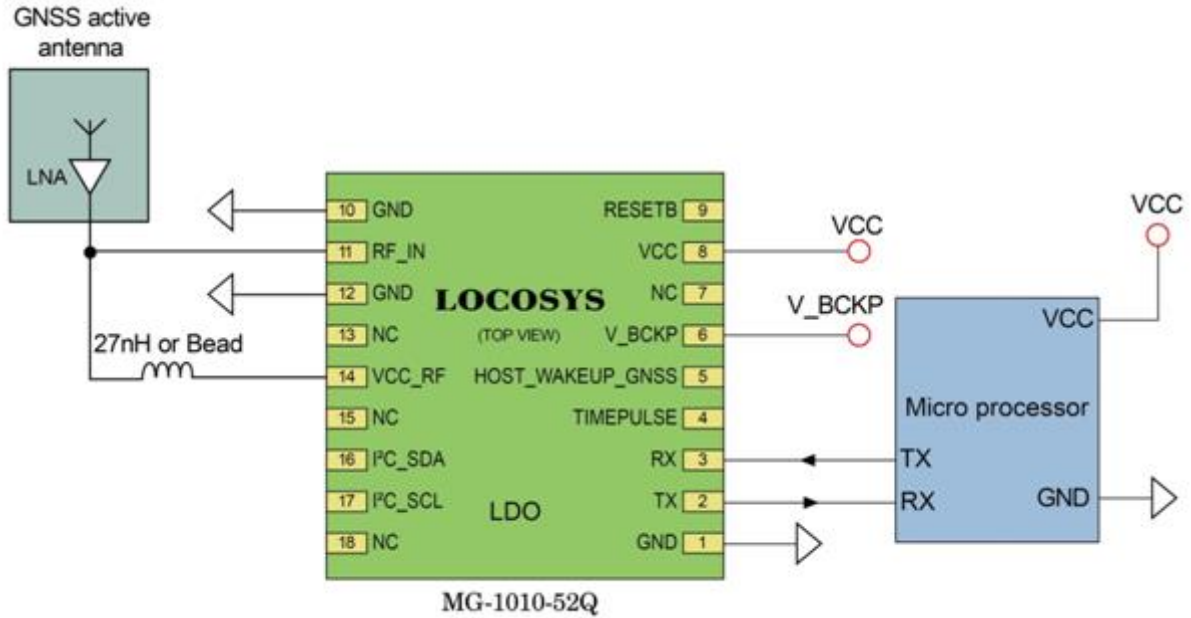

Figure 2: Typical application circuit that uses an active antenna

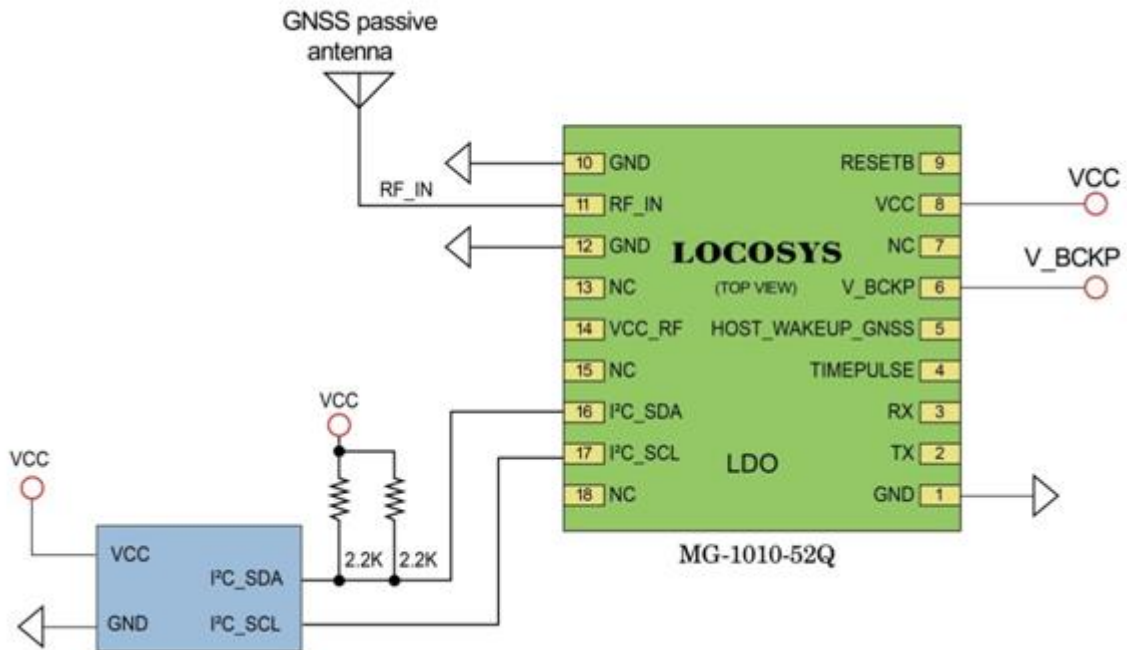

Figure 3: Typical interface of Passive antenna.

5. GNSS Performance

Table 1: Module Key Features

Frequency	GPS/QZSS: L1 C/A, L1C GLONASS: L1OF GALILEO: E1 BEIDOU: B1I, B1C	
Channels	Support 47 channels	
Update rate	1Hz default, up to 10Hz	
Sensitivity	Tracking	-165dBm
	Cold start	-148dBm
Acquisition Time	Hot start (Open Sky)	1s (typical)
	Cold Start (Open Sky)	28s (typical) without AGPS
		< 15s (typical) with AGPS (ephemeris prediction)
Position Accuracy	Autonomous: 1.5m (CEP) ⁽¹⁾	
Max. Altitude	< 18,000 m ⁽²⁾	
Max. Velocity	< 500 m/s	
Protocol Support	NMEA 0183 ver. 4.1 (For Normal Version) (Default)	115200 bps ⁽³⁾ , 8 data bits, no parity, 1 stop bits 1Hz: GGA, GLL, GSA, GSV, RMC, VTG, GST
	UBX binary (For Drone Version) (Option)	230400 bps ⁽³⁾ , 8 data bits, no parity, 1 stop bits UBX-NAV-PVT (10Hz), UBX-NAV-DOP (10Hz), UBX-NAV-TIMEGPS (1Hz)

<Note>

1. Open sky, demonstrated with a good external LNA.
2. The maximum altitude of the balloon mode is 80,000 m.
3. Both baud rate and output message rate are configurable to be factory default.

6. Antenna Consideration

The MG-1010-52Q module is designed for use with both active and passive antennas, emphasizing those with higher antenna gain. The recommended choice is the cost-effective and sensitive passive ceramic patch antenna. A 50-ohm larger dimension output ceramic patch antenna with higher gain can be directly connected to the module's RF input.

Typically, the ceramic patch antenna and MG-1010-52Q module are placed on opposite sides of the PCB to minimize the noise received from the patch antenna. To improve signal reception, consider using a larger ground plane under the patch antenna, correlating with increased overall antenna gain. The center frequency of the ceramic patch antenna changes with the ground plane size. The antenna's frequency bandwidth should cover 1573MHz to 1606MHz on the PCB for optimal operation. Consult the ceramic patch antenna vendor to select or tune an antenna that best matches the customer's PCB.

Alternatively, an active antenna with a built-in low-noise amplifier (LNA) and a coaxial cable offers remote placement flexibility but requires an extra power supply. Active antennas generally outperform passive patch antennas in low-signal environments despite a higher cost. An active antenna with a gain of 10 to 20dB and a noise figure below 1.5dB is suitable for use with the MG-1010-52Q module.

Table 2: Recommended Antenna Setting

Antenna Type	Passive	Active
GPS&QZSS Frequency (MHz)	1575.42 +/- 2 (L1)	1575.42 +/- 2 (L1)
BDS Frequency (MHz)	1561 .098 +/- 2(B1)	1561 .098+/- 2(B1)
GLONASS Frequency (MHz)	1602MHz +/- 4(L1)	1602MHz +/- 4(L1)
GALILEO Frequency (MHz)	1559-1592(E1)	1559-1592(E1)
VSWR	< 2 (typical)	< 2 (typical)
Polarization	RHCP	RHCP
Antenna Gain	> 0dBi	> -2dBi
LNA Gain		20dB (typical)
Noise Figure		< 1.5dB
Total Gain		> 18dBi

7. Software interface

7.1 NMEA output message

Table 3: NMEA output message

NMEA record	Description
GGA	Global positioning system fixed data
GLL	Geographic position - latitude/longitude
GSA	GNSS DOP and active satellites
GSV	GNSS satellites in view
RMC	Recommended minimum specific GNSS data
VTG	Course over ground and ground speed
GST	Estimated error in position solution

- GGA--- Global Positioning System Fixed Data

Contains the values for the following example:

```
$GNGGA,061300.000,2503.71255,N,12138.74493,E,2,38,0.44,121.12,M,15.32,M,,*7E
```

Table 4: GGA Data Format

Name	Example	Units	Description
Message ID	\$GNGGA		GGA protocol header
UTC Time	061300.000		hhmmss.sss
Latitude	2503.71255		ddmm.mmmmm
N/S indicator	N		N=north or S=south
Longitude	12138.74493		dddmm.mmmmm
E/W Indicator	E		E=east or W=west
Position Fix Indicator	2		See Table 5
Satellites Used	38		Number of satellites in view
HDOP	0.44		Horizontal Dilution of Precision (meters)
MSL Altitude	121.12	meters	Antenna Altitude above/below mean-sea-level (geoid) (in meters)
Units	M	meters	Units of antenna altitude, meters
Geoidal Separation	15.32	meters	
Units	M	meters	Units of geoidal separation, meters
Age of diff. GNSS data		second	Null fields when DGPS is not used
Diff. Ref. Station ID			Differential reference station ID, 0000-1023
Checksum	*7E		Checksum
<CR> <LF>			End of message termination

Table 5: Position Fix Indicators

Value	Description
0	No position fix
1	Autonomous GNSS fix
2	Differential GNSS fix
4	RTK fixed
5	RTK float
6	Estimated/Dead reckoning fix

- GLL--- Geographic Position – Latitude/Longitude

Contains the values for the following example:

\$GNGLL,2503.71255,N,12138.74493,E,061300.000,A,D*42

Table 6: GLL Data Format

Name	Example	Units	Description
Message ID	\$GNGLL		GLL protocol header
Latitude	2503.71255		ddmm.mmmmm
N/S indicator	N		N=north or S=south
Longitude	12138.7493		dddmm.mmmmm
E/W indicator	E		E=east or W=west
UTC Time	061300.000		hhmmss.sss
Status	A		A=data valid or V=data not valid
Mode	D		N = No position fix A = Autonomous GNSS fix D = Differential GNSS fix R = RTK fixed F = RTK float E = Estimated/Dead reckoning fix
Checksum	*42		
<CR> <LF>			End of message termination

- GSA---GNSS DOP and Active Satellites

Contains the values for the following example:

\$GNGSA,A,3,19,195,17,06,20,11,09,02,194,12,05,04,0.81,0.44,0.68,1*04

\$GNGSA,A,3,14,,,,,,,,,0.81,0.44,0.68,1*03

\$GNGSA,A,3,66,81,88,65,79,82,,,,,,,,,0.81,0.44,0.68,2*0B

\$GNGSA,A,3,03,15,34,27,30,,,,,,,,,0.81,0.44,0.68,3*02

GNGSA,A,3,33,40,07,10,38,28,08,41,13,14,43,42,0.81,0.44,0.68,4*0B

\$GNGSA,A,3,11,39,,,,,,,,,0.81,0.44,0.68,4*09

Table 7: GSA Data Format

Name	Example	Units	Description
Message ID	\$GNGSA		GSA protocol header
Mode 1	A		See Table 8
Mode 2	3		See Table 9
ID of satellite used	19		SV on Channel 1
ID of satellite used	195		SV on Channel 2
ID of satellite used			SV on Channel 12
PDOP	0.81		Position Dilution of Precision
HDOP	0.44		Horizontal Dilution of Precision
VDOP	0.68		Vertical Dilution of Precision
GNSS system ID	1		See Table 10
Checksum	*04		
<CR> <LF>			End of message termination

Table 8: Mode 1

Value	Description
M	Manually set to operate in 2D or 3D mode
A	Automatically switching between 2D or 3D mode

Table 9: Mode 2

Value	Description
1	No position fix
2	2D fix
3	3D fix

Table 10: GNSS system ID

Value	Description
1	GPS
2	GLONASS
3	GALILEO
4	BEIDOU
6	IRNSS

- GSV---GNSS Satellites in View

Contains the values for the following example:

```
$GPGSV,4,1,15,196,73,108,46,19,72,077,47,195,71,061,47,199,59,164,22,1*5B
$GPGSV,4,2,15,17,54,115,47,06,49,003,48,20,44,248,47,11,36,306,46,1*6E
$GPGSV,4,3,15,09,35,079,45,02,31,307,45,194,28,175,43,12,25,302,43,1*52
$GPGSV,4,4,15,05,14,230,38,04,14,051,38,14,11,173,43,1*53
$GLGSV,2,1,07,66,71,107,44,81,39,356,48,88,36,067,47,67,33,187,,1*7B
$GLGSV,2,2,07,65,25,033,46,79,17,262,47,82,08,315,43,1*46
$GAGSV,2,1,05,03,49,122,45,15,47,342,45,34,37,056,43,27,33,273,43,7*7B
$GAGSV,2,2,05,30,30,208,41,7*49
$GBGSV,4,1,14,33,72,072,50,40,63,187,48,07,63,217,45,10,63,251,45,1*74
$GBGSV,4,2,14,38,58,328,48,28,56,353,49,08,52,306,44,41,47,200,48,1*75
$GBGSV,4,3,14,13,47,291,45,14,45,047,45,43,44,092,47,42,20,040,42,1*71
$GBGSV,4,4,14,11,20,105,41,39,11,172,42,1*78
```

Table 11: GSV Data Format

Name	Example	Units	Description
Message ID	\$GPGSV		GSV protocol header GP=GPS/QZSS, GL=GLONSS, GA=GALILEO, GB=BEIDOU, GI=IRNSS.
Total number of messages	4		Range 1 to 9
Message number	1		Range 1 to 9
Satellites in view	15		
Satellite ID	196		Channel 1
Elevation	73	degrees	Channel 1 (Range 00 to 90)
Azimuth	108	degrees	Channel 1 (Range 000 to 359)
SNR (C/No)	46	dB-Hz	Channel 1 (Range 00 to 99, null when not tracking)
Satellite ID	199		Channel 4
Elevation	59	degrees	Channel 4 (Range 00 to 90)
Azimuth	164	degrees	Channel 4 (Range 000 to 359)
SNR (C/No)	22	dB-Hz	Channel 4 (Range 00 to 99, null when not tracking)
Signal ID	1		GPS/QZSS: L1 C/A=1 GLONASS: L1 C/A=1 GALILEO: E1=7 BEIDOU: B1=1, B1C=3
Checksum	*5B		
<CR> <LF>			End of message termination

● **RMC---Recommended Minimum Specific GNSS Data**

Contains the values for the following example:

\$GNRMC,061300.000,A,2503.71255,N,12138.74493,E,0.01,30.70,150622,,D,V*38

Table 12: RMC Data Format

Name	Example	Units	Description
Message ID	\$GNRMC		RMC protocol header
UTC Time	061300.000		hhmmss.sss
Status	A		A=data valid or V=data not valid
Latitude	2503.71255		ddmm.mmmm
N/S Indicator	N		N=north or S=south
Longitude	12138.74493		dddmm.mmmmm
E/W Indicator	E		E=east or W=west
Speed over ground	0.001	knots	True
Course over ground	30.70	degrees	
Date	150622		ddmmyy
Magnetic variation		degrees	
Variation sense			E=east or W=west
Mode	D		N = No position fix A = Autonomous GNSS fix D = Differential GNSS fix R = RTK fixed F = RTK float E = Estimated/Dead reckoning fix
Navigational status indicator	V		S = Safe C = Caution U = Unsafe V = Void
Checksum	*38		
<CR> <LF>			End of message termination

● **VTG---Course Over Ground and Ground Speed**

Contains the values for the following example:

\$GNVTG,30.70,T,,M,0.01,N,0.01,K,D*12

Table 13: VTG Data Format

Name	Example	Units	Description
Message ID	\$GPVTG		VTG protocol header
Course over ground	30.70	degrees	Measured heading

Reference	T		True
Course over ground		degrees	Measured heading
Reference	M		Magnetic
Speed over ground	0.001	knots	Measured speed
Units	N		Knots
Speed over ground	0.001	km/hr	Measured speed
Units	K		Kilometer per hour
Mode	D		N = No position fix A = Autonomous GNSS fix D = Differential GNSS fix R = RTK fixed F = RTK float E = Estimated/Dead reckoning fix
Checksum	*12		
<CR> <LF>			End of message termination

- GST---Estimated error in position solution

Contains the values for the following example

\$GNGST,061300.000,2.6,1.9,1.6,169.8,1.9,1.6,6.8*71

Table 14: GST Data Format

Name	Example	Units	Description
Message ID	\$GNGST		GST protocol header
UTC Time	061300.000		hhmmss.sss
RangeRMS	2.6	meters	RMS value of the standard deviation of the ranges
stdMajor	1.9	meters	Standard deviation of semi-major axis of error ellipse
stdMinor	1.6	Meters	Standard deviation of semi-minor axis of error ellipse
Orient	169.8	degrees	Orientation of semi-major axis of error ellipse
stdLat	1.9	meters	Standard deviation of latitude error
stdLong	1.6	meters	Standard deviation of longitude error
stdAlt	6.8	meters	Standard deviation of altitude error
Checksum	*71		
<CR> <LF>			End of message termination

7.2 Proprietary commands

The commonly used commands are in the following.

7.2.1 ID: 001

[Description]

PAIR_ACK. Acknowledge of the input command.

[Return]

\$PAIR001,Command_ID,Result*CS<CR><LF>

Command_ID: The command / packet type the acknowledge responds.

Result: The result of the command.

0: The command was successfully sent.

1: The command is processing. You must wait for the result.

2: Sending the command failed.

3: This command ID is not supported.

4: Command parameter error. Out of range / some parameters were lost / checksum error.

5: Service is busy. You can try again soon.

[Example]

Send:

\$PAIR002*38\r\n

Response:

\$PAIR001,002,0*39\r\n ==> Success

7.2.2 ID: 002

[Description]

Power on the GNSS system. Include DSP/RF/Clock and other GNSS sections.

[Data Field]

\$PAIR002*CS<CR><LF>

[Return]

PAIR_ACK for send result.

[Example]

Send:

\$PAIR002*38\r\n

Response:

\$PAIR001,002,1*38\r\n ==> The power on process is running. Please wait a moment.

\$PAIR001,002,0*39\r\n ==> Power on was successful.

7.2.3 ID: 003

[Description]

Power off GNSS system. Include DSP/RF/Clock and other GNSS sections. The location service is not available after this command is executed. The module can still receive configuration commands.

[Data Field]

\$PAIR003*CS<CR><LF>

[Return]

PAIR_ACK for send result.

[Example]

Send:

\$PAIR003*39\r\n

Response:

\$PAIR001,003,1*39\r\n ==> The power off process is running. Please wait a moment.

\$PAIR001,003,0*38\r\n ==> Power off was successful.

7.2.4 ID: 004

[Description]

Hot Start. Use the available data in the NVRAM.

[Data Field]

\$PAIR004*CS<CR><LF>

[Return]

PAIR_ACK for send result.

[Example]

Send:

\$PAIR004*3E\r\n

Response:

\$PAIR001,004,0*3F\r\n ==> Success

7.2.5 ID: 005

[Description]

Warm Start. Not using Ephemeris data at the start.

[Data Field]

\$PAIR005*CS<CR><LF>

[Return]

PAIR_ACK for send result.

[Example]

Send:

```
$PAIR005*3F\r\n
```

Response:

```
$PAIR001,005,0*3E\r\n ==> Success
```

7.2.6 ID: 006

[Description]

Cold Start. Not using the Position, Almanac and Ephemeris data at the start.

[Data Field]

```
$PAIR006*CS<CR><LF>
```

[Return]

PAIR_ACK for send result.

[Example]

Send:

```
$PAIR006*3C\r\n
```

Response:

```
$PAIR001,006,0*3D\r\n ==> Success
```

7.2.7 ID: 007

[Description]

Full Cold Start.

In addition to Cold start, this command clears the system/user configurations at the start.

It resets the GNSS module to the factory default.

[Data Field]

```
$PAIR007*CS<CR><LF>
```

[Return]

PAIR_ACK for send result.

[Example]

Send:

```
$PAIR007*3D\r\n
```

Response:

```
$PAIR001,007,0*3C\r\n ==> Success
```

7.2.8 ID: 864

[Description]

Set baud rate configuration.

[Data Field]

\$PAIR864,<Port_Type>,<Port_Index>,<Baudrate>*CS<CR><LF>

Port_Type: HW Port Type.

0: UART

Port_Index: HW Port Index

0: UART0

Baudrate: the baud rate needs config.

Support 115200, 230400, 460800, 921600, 3000000

[Return]

PAIR_ACK for send result.

[Example]

Send:

\$PAIR864,0,0,115200*1B\r\n

Response:

\$PAIR001,864,0*31\r\n ==> Success

[Note]

The change will take effect after reboot.

7.2.9 ID: 050

[Description]

Set Position Fix Interval.

If set less than 1000 ms, ASCII NMEA will automatically increase the update interval in order to decrease IO throughput.

[Data Field]

\$PAIR050,<Fix_Interval>*CS<CR><LF>

Fix_Interval: Position fix interval in milliseconds (ms). [Range: 100 ~ 1000]

[Return]

PAIR_ACK for send result.

[Example]

Send:

\$PAIR050,1000*12\r\n

Response:

\$PAIR001,050,0*3E\r\n ==> Success

7.2.10 ID: 051

[Description]

Get Position Fix Interval.

[Data Field]

\$PAIR051*CS<CR><LF>

[Return]

1. PAIR_ACK for send result.
2. \$PAIR050,<Fix_Interval>*CS<CR><LF>

Fix_Interval: Position fix interval in milliseconds (ms). [Range: 100 ~ 1000]

[Example]

Send:

\$PAIR051*3E\r\n

Response:

\$PAIR001,051,0*3F\r\n ==> Success

\$PAIR051,1000*13\r\n

7.2.11 ID: 062

[Description]

Set the NMEA sentence output interval of corresponding NMEA type.

[Data Field]

\$PAIR062,<Type>,<Output_Rate>*CS<CR><LF>

Type: NMEA Type

-1 Reset all sentence to default value.

- | | | |
|---|---------------|--|
| 0 | NMEA_SEN_GGA, | // GGA interval - GPS Fix Data |
| 1 | NMEA_SEN_GLL, | // GLL interval - Geographic Position - Latitude longitude |
| 2 | NMEA_SEN_GSA, | // GSA interval - GNSS DOPS and Active Satellites |
| 3 | NMEA_SEN_GSV, | // GSV interval - GNSS Satellites in View |
| 4 | NMEA_SEN_RMC, | // RMC interval - Recommended Minimum Specific GNSS Sentence |
| 5 | NMEA_SEN_VTG, | // VTG interval - Course Over Ground and Ground Speed |
| 6 | NMEA_SEN_ZDA, | // ZDA interval - Time & Date |
| 7 | NMEA_SEN_GRS, | // GRS interval - GNSS Range Residuals |
| 8 | NMEA_SEN_GST, | // GST Interval - GNSS Pseudorange Error Statistics |

Output_Rate: Output interval setting (Valid range: 0~20)

- 0 - Disabled or not supported sentence
- 1 - Output once every one position fix
- 2 - Output once every two position fixes

- 3 - Output once every three position fixes
- 4 - Output once every four position fixes
- 5 - Output once every five position fixes

[Return]

PAIR_ACK for send result.

[Example]

Send:

```
$PAIR062,0,3*3D\r\n
```

Response:

```
$PAIR001,062,0*3F\r\n ==> Success
```

7.2.12 ID: 063

[Description]

Get the NMEA sentence output interval of corresponding NMEA type.

[Data Field]

```
$PAIR063,<Type>*CS<CR><LF>
```

Type: NMEA Type

-1 return all sentence configuration.

- 0 NMEA_SEN_GGA, // GGA interval - GPS Fix Data
- 1 NMEA_SEN_GLL, // GLL interval - Geographic Position - Latitude longitude
- 2 NMEA_SEN_GSA, // GSA interval - GNSS DOPS and Active Satellites
- 3 NMEA_SEN_GSV, // GSV interval - GNSS Satellites in View
- 4 NMEA_SEN_RMC, // RMC interval - Recommended Minimum Specific GNSS Sentence
- 5 NMEA_SEN_VTG, // VTG interval - Course Over Ground and Ground Speed
- 6 NMEA_SEN_ZDA, // ZDA interval - Time & Date
- 7 NMEA_SEN_GRS, // GRS interval - GNSS Range Residuals
- 8 NMEA_SEN_GST, // GST Interval - GNSS Pseudorange Error Statistics

[Return]

1. PAIR_ACK for send result.
2. \$PAIR063,<Type>,<Output_Rate>*CS<CR><LF>

Type: NMEA Type

- 0 NMEA_SEN_GGA, // GGA interval - GPS Fix Data
- 1 NMEA_SEN_GLL, // GLL interval - Geographic Position - Latitude longitude
- 2 NMEA_SEN_GSA, // GSA interval - GNSS DOPS and Active Satellites
- 3 NMEA_SEN_GSV, // GSV interval - GNSS Satellites in View
- 4 NMEA_SEN_RMC, // RMC interval - Recommended Minimum Specific GNSS

Sentence

5 NMEA_SEN_VTG, // VTG interval - Course Over Ground and Ground Speed
6 NMEA_SEN_ZDA, // ZDA interval - Time & Date

7 NMEA_SEN_GRS, // GRS interval - GNSS Range Residuals
8 NMEA_SEN_GST, // GST Interval - GNSS Pseudorange Error Statistics

Output_Rate: Output interval setting (Valid range: 0~20, default value: 1)

0 - Disabled or not supported sentence

1 - Output once every one position fix

2 - Output once every two position fixes

3 - Output once every three position fixes

4 - Output once every four position fixes

5 - Output once every five position fixes

[Example]

Send:

```
$PAIR063,0*23\r\n
```

Response:

```
$PAIR001,063,0*3E\r\n ==> Success
```

```
$PAIR063,0,3*3C\r\n
```

7.2.13 ID: 070

[Description]

Set the static navigation speed threshold.

If the actual speed is less than the threshold, the output position remains the same and the output speed will be zero.

If the threshold value is set to 0, this function is disabled.

[Data Field]

```
$PAIR070,<Speed_thresholld>*CS<CR><LF>
```

Speed_threshold. 0~20 dm/s. Default value is 0 dm/s.

The minimum is 1 dm/s, the maximum is 20 dm/s.

1 dm/s = 0.1m/s

[Return]

1. PAIR_ACK for send result.

[Example]

Send:

```
$PAIR070,4*25\r\n
```

Response:

```
$PAIR001,070,0*3C\r\n ==> Success
```

7.2.14 ID: 071

[Description]

Query the static navigation speed threshold.

[Data Field]

\$PAIR071*CS<CR><LF>

[Return]

1. PAIR_ACK for send result.
2. \$PAIR071,<Speed_threshold>*CS<CR><LF>

Speed_threshold: 0~2 m/s.

The maximum is 2.0 m/s.

[Example]

Send:

\$PAIR071*3C\r\n

Response:

\$PAIR001,071,0*3D\r\n ==> Success

\$PAIR071,0.4*3A\r\n

7.2.15 ID: 080

[Description]

Set navigation mode.

[Data Field]

\$PAIR080,<CmdType>*CS<CR><LF>

CmdType:

0. Normal mode: For general purpose
1. Fitness mode: For running and walking purpose so that the low-speed (< 5 m/s) movement will have more of an effect on the position calculation.
2. Reserved
3. Balloon mode: For high-altitude balloon purpose that the vertical movement will have more effect on the position calculation
4. Stationary mode: For stationary applications with zero dynamics.
5. Drone mode: used for drone applications with equivalent dynamics range and vertical application on different flight phase. (Ex. Hovering, cruising, etc.)
6. Reserved
7. Swimming mode: For swimming purpose so that it smooths the trajectory and improves the accuracy of distance calculation.

[Return]

PAIR_ACK for send result.

[Example]

Send:

\$PAIR080,1*2F\r\n ==> Enter fitness mode.

Response:

\$PAIR001,080,0*33\r\n ==> Success

7.2.16 ID: 081

[Description]

Get navigation mode.

[Data Field]

\$PAIR081*CS<CR><LF>

[Return]

1. PAIR_ACK for send result.
2. \$PAIR081,<CmdType>*CS<CR><LF>

CmdType:

- '0' [Default Value] Normal mode: For general purpose
- '1' Fitness mode: For running and walking activities so that the low-speed (< 5 m/s) movement will have more of an effect on the position calculation.
- '2' Reserved
- '3' Balloon mode: For high-altitude balloon purpose that the vertical movement will have more effect on the position calculation
- '4' Stationary mode: For stationary applications where a zero dynamic assumed.
- '5' Drone mode: used for drone applications with equivalent dynamics range and vertical application on different flight phase. (Ex. Hovering, cruising, etc.)
- '6' Reserved
- '7' Swimming mode: For swimming purpose so that it smooths the trajectory and improves the accuracy of distance calculation.

[Example]

Send:

\$PAIR081*33\r\n

Response:

\$PAIR001,081,0*32\r\n ==> Success

\$PAIR081,1*2E\r\n ==> Current is fitness mode.

7.2.17 ID:158

[Description]

Enable B1c.

[Data Field]

\$PAIR158,<Enable>*CS<CR><LF>

Enable:

0: Disable

1: Enable

[Return]

1. PAIR_ACK for send result.

[Example]

Send:

\$PAIR158,1*2B\r\n

Response:

\$PAIR001,158,0*37\r\n ==> Success

7.2.18 ID:159

[Description]

Query output B1c enable status.

[Data Field]

\$PAIR159*CS<CR><LF>

[Return]

1. PAIR_ACK for send result.

2. \$PAIR159,<Enable>*CS<CR><LF>

Enable:

0: Disable

1: Enable

[Example]

Send:

\$PAIR159*37\r\n

Response:

\$PAIR001,159,0*36\r\n ==> Success

\$PAIR159,1*2A\r\n

7.2.19 ID: 400

[Description]

Set DGPS correction data source mode.

[Data Field]

\$PAIR400,<Mode> *CS<CR><LF>

Mode: DGPS data source mode.

'0': No DGPS source
'1': RTCM
'2': SBAS (Include WAAS/EGNOS/GAGAN/MSAS)
'3': QZSS SLAS

[Return]

PAIR_ACK for send result.

[Example]

Send:

\$PAIR400,2*20\r\n ==> Set SBAS Mode

Response:

\$PAIR001,400,0*3F\r\n ==> Success

7.2.20 ID: 401

[Description]

Query the DGPS data source mode.

[Data Field]

\$PAIR401*CS<CR><LF>

[Return]

1. PAIR_ACK for send result.
2. \$PAIR401,<Mode>*CS<CR><LF>

Mode: DGPS data source mode.

'0': No DGPS source
'1': RTCM
'2': SBAS (Include WAAS/EGNOS/GAGAN/MSAS)
'3': QZSS SLAS

[Example]

Send:

\$PAIR401*3F\r\n

Response:

\$PAIR001,401,0*3E\r\n ==> Success
\$PAIR401,2*21\r\n ==> SBAS Mode

7.2.21 ID: 410

[Description]

Enable searching a SBAS satellite or not.

When navigation mode is Fitness or Swimming mode, SBAS is not supported.

[Data Field]

\$PAIR410,<Enabled>*CS<CR><LF>

Enabled: Enable or disable

'0' = Disable

'1' = Enable

[Return]

PAIR_ACK for send result.

[Example]

Send:

```
$PAIR410,1*22\r\n ==> Enable SBAS
```

Response:

```
$PAIR001,410,0*3E\r\n ==> Success
```

7.2.22 ID: 420

[Description]

Enable the QZSS SLAS (Sub-meter Level Augmentation Service) operation.

When navigation mode is Fitness or Swimming mode, QZSS SLAS is not supported.

[Data Field]

```
$PAIR420,<Enabled>*CS<CR><LF>
```

Enabled: Enable or disable

'0' = Disable

'1' = Enable

[Return]

PAIR_ACK for send result.

[Example]

Send:

```
$PAIR420,1*21\r\n ==> Enable QZSS SLAS
```

Response:

```
$PAIR001,420,0*3D\r\n ==> Success
```

7.2.23 ID: 513

[Description]

Save the current configuration from RTC RAM to flash.

[Data Field]

```
$PAIR513*CS<CR><LF>
```

[Return]

PAIR_ACK for send result.

[Example]

Send:

```
$PAIR513*3D\r\n
```

Response:

```
$PAIR001,513,0*3C\r\n
```

[Note]

The changes of the configuration are kept in the RTC RAM that is powered from V_BCKP pin. If the power from V_BCKP pin is not kept, the changes will be lost after system reboot. The user can use this command to save the changes into the non-volatile flash memory. When the update rate is greater than 1Hz, this command can only be set when the GNSS system is powered off.

7.2.24 ID: 514

[Description]

Clear the current configuration and restore the factory default settings. This function does not support run time restore when GNSS is power on. Please send \$PAIR003 command to power off GNSS before using this command.

[Data Field]

```
$PAIR514*CS<CR><LF>
```

[Return]

PAIR_ACK for send result.

[Example]

Send:

```
$PAIR514*3A\r\n
```

Response:

```
$PAIR001,514,0*3B\r\n
```

7.2.25 ID: 066

[Description]

Configure the receiver to start searching for satellites. The setting is available when the NVRAM data is valid.

The device restarts when it receives this command.

Support constellation: GPS, GPS+GLONASS, GPS+GALILEO, GPS+BEIDOU, GPS+GLONASS+GALILEO+BEIDOU.

QZSS is always switchable.

[Data Field]

```
$PAIR066,<GPS_Enabled>,<GLONASS_Enabled>,<Galileo_Enabled>,<BeiDou_Enabled>,<QZSS_Enabled>,<NavIC_Enabled>*CS<CR><LF>
```

GPS_Enabled:

"0", disable (DO NOT search GPS satellites).

"1", search GPS satellites.

GLONASS_Enabled:

"0", disable (DO NOT search GLONASS satellites).

"1", search GLONASS satellites.

Galileo_Enabled:

"0", disable (DO NOT search Galileo satellites).

"1", search Galileo satellites.

BeiDou_Enabled:

"0", disable (DO NOT search BeiDou satellites).

"1", search BeiDou satellites.

QZSS_Enabled:

"0", disable (DO NOT search QZSS satellites).

"1", search QZSS satellites.

NavIC_Enabled:

"0", disable (DO NOT search NavIC satellites).

"1", search NavIC satellites.

[Return]

PAIR_ACK for send result.

[Example]

Send:

\$PAIR066,1,0,0,0,0*3B\r\n ==> Search GPS satellites only.

Response:

\$PAIR001,066,0*3B\r\n ==> Success

Send:

\$PAIR066,1,0,1,0,1,0*3B\r\n ==> Search GPS, GALILEO and QZSS satellites.

Response:

\$PAIR001,066,0*3B\r\n ==> Success

7.2.26 ID: 154

[Description]

Enable to output Return Link Message from navigation data.

[Data Field]

\$PAIR154,<Enable>*CS<CR><LF>

Enable:

0: disable

1: enable

[Return]

PAIR_ACK for send result.

[Example]

Send:

\$PAIR154,1*27\r\n

Response:

\$PAIR001,154,0*3B\r\n ==> Success

7.2.27 ID: 155

[Description]

Query output Return Link Message status.

[Data Field]

\$PAIR155*CS<CR><LF>

Enable:

0: disable

1: enable

[Return]

1. PAIR_ACK for send result.

2. \$PAIR155,<Enable>*CS<CR><LF>

Enable:

0: Disable

1: Enable

[Example]

Send:

\$PAIR155*3B\r\n

Response:

\$PAIR001,155,0*3A\r\n ==> Success

\$PAIR155,1*26\r\n

7.3 Proprietary PLSC commands

Table 15: PLSC commands

Command	Example
\$PLSC,NMEAUBX,0*74	Set the module output UBX binary
\$PLSC,NMEAUBX,1*75	Set the module output NMEA
\$PLSC,NMEAUBX,2*76	Set the module output both NMEA and UBX binary
\$PLSC,UBX,PVT,0*0D	Disable output of the message UBX-NAV-PVT
\$PLSC,UBX,PVT,1*0C	Enable output of the message UBX-NAV-PVT
\$PLSC,UBX,DOP,0*04	Disable output of the message UBX-NAV-DOP
\$PLSC,UBX,DOP,1*05	Enable output of the message UBX-NAV-DOP
\$PLSC,UBX,TIMEGPS,0*0E	Disable output of the message UBX-NAV-TIMEGPS
\$PLSC,UBX,TIMEGPS,1*0F	Enable output of the message UBX-NAV-TIMEGPS

<Note>

1. Please add the carriage return (\r) and line feed (\n) to the end of the command.
2. The UBX to NMEA output command is only used for production line testing.

8. Pin assignment and descriptions

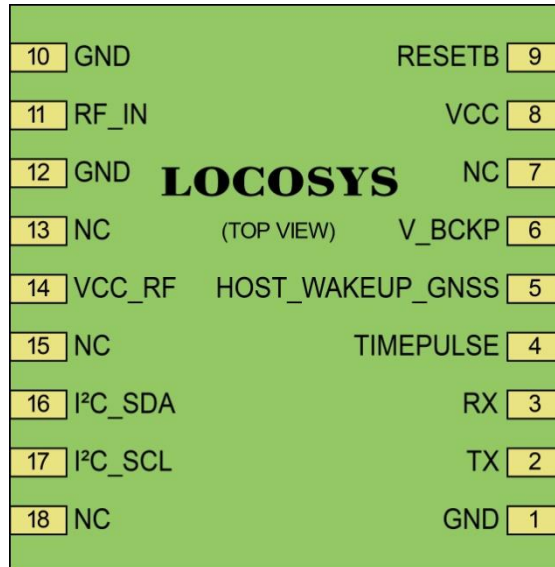

Figure 4: Pin Assignment

Table 16: Pin descriptions

Pin #	Name	Type	Description	Note
1	GND	P	Ground	
2	TX	O	MUX IO: GPIO, UART 0 Serial Data Transmit (UOUT0)	
3	RX	I	MUX IO: GPIO, UART 0 Serial Data Receive (UIN0)	
4	TIMEPULSE	O	Time pulse (PPS, default 100 ms pulse/sec when GNSS fix is available)	
5	HOST_WAKEUP_GNSS	I	Host wakes up GNSS module. Leave unconnected if not used.	
6	V_BCKP	P	Buckup Power input Pin	1
7	NC		Not connect	
8	VCC	P	Main power supply, 3.3V +/- 10%	
9	RESETB	I	Internal 10K ohm pull-up resistor. Mode control pin between RTC and normal mode. Leave unconnected if not used.	
10	GND	P	Ground	
11	RF_IN	I	GNSS RF signal input The overall gain of the active antenna must be no greater than 35dB.	
12	GND	P	Ground	
13	NC		Not connect	

14	VCC_RF	O	Output voltage for active antenna.	
15	NC		Not connect.	
16	I ² C_SDA	I/O	I ² C serial data. Leave unconnected if not used.	
17	I ² C_SCL	I	I ² C serial clock input. Leave unconnected if not used.	
18	NC		Not connect	

<Note>

1. In order to get the advantage of hybrid ephemeris prediction, this pin must be always powered during the period of effective ephemeris prediction.

9. DC & Temperature characteristics

Absolute maximum ratings for power supply and voltage on digital pins of the module are listed in the following table.

Table 17: Module Power Supply Ratings

Parameter	Symbol	Ratings	Units
DC Supply Input Voltage	VCC _{ABS}	3.63	V
Input Backup Battery Voltage	V_BCKP _{ABS}	3.63	V
Operating Temperature Range	T _{OPR_ABS}	-40 ~ 85	°C
Storage Temperature Range	T _{STG_ABS}	-40 ~ 85	°C

Table 18: DC Electrical characteristics

Parameter	Symbol	Conditions	Min.	Typ.	Max.	Units
DC Supply Input Voltage	VCC		3	3.3	3.6	V
Input Backup Battery Voltage	V_BCKP		1.62		3.63	V
VCC_RF Output Voltage	VCC_RF			VCC		V
Supply Current	I _{SS}	VCC = 3.3V, w/o active antenna, Peak Acquisition Tracking		25 29 ⁽²⁾	140 ⁽¹⁾	mA mA mA
	I _{RTC}	VCC=3.3V, RESETB=0V		191		uA
Backup Battery Current	I _{BAT}	VCC = 0V		32		uA
VCC_RF Output Current ⁽³⁾	I _{OUT}				30	mA
High Level Input Voltage	V _{IH}		2			V
Low Level Input Voltage	V _{IL}				0.8	V
High Level Output Voltage	V _{OH}		2.4			V
Low Level Output Voltage	V _{OL}				0.4	V

<Note>

1. This happens when downloading AGPS data to the module.
2. Measured when position fix (1Hz) is available, input voltage is 3.3V and the function of self-generated ephemeris prediction is inactive.

Table 19: Temperature characteristics

Parameter	Symbol	Ratings	Units
DC Supply Input Voltage	VCC _{ABS}	3.63	V
Input Backup Battery Voltage	V_BCKP _{ABS}	3.63	V

10. Mechanical specification

10.1 Outline dimensions

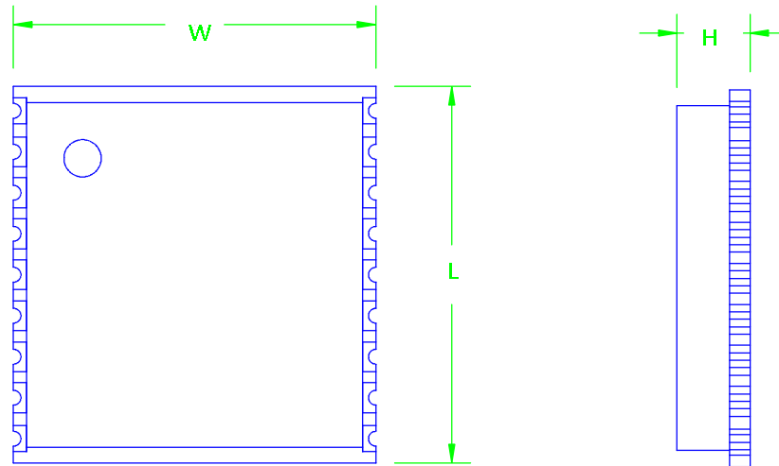

Figure 5: Top View and Side View (Unit: mm)

Table 20: Bottom Dimension (Unit: mm)

Symbol	Min. (mm)	Typ. (mm)	Max. (mm)
W	9.5	9.7	9.9
L	9.7	10.1	10.5
H	1.8	2.0	2.2

10.2 Recommended land pattern dimensions

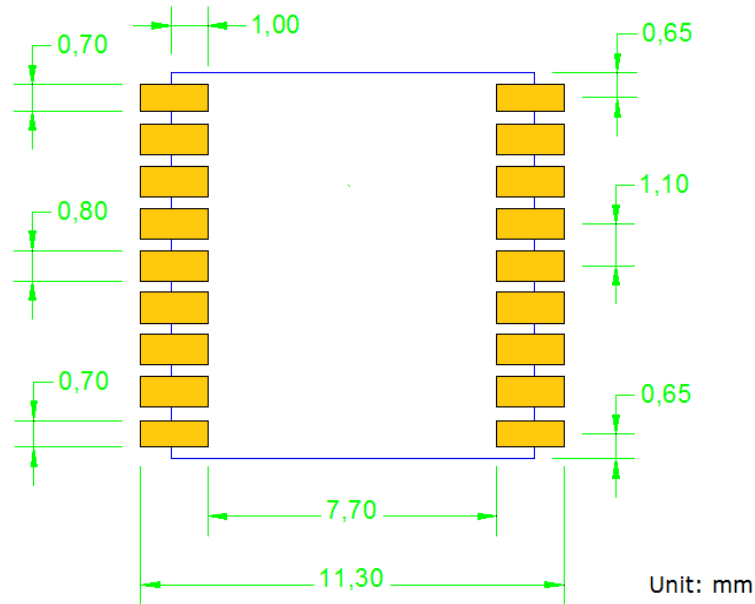

Figure 6: Footprint of Recommendation (Unit: mm)

Note: The recommended land pattern dimensions are shown for reference only, as actual pad layouts may vary depending on application.

11. Reel Packing information

11.1 ESD precaution

GNSS modules are electrostatic sensitive devices. Handling the modules without proper ESD protection may result in severe damage to them. ESD protection must be implemented throughout the processing, handling and even when the modules are being returned for repair.

11.2 Packaging

The modules are sealed in a moisture barrier ESD bag with the appropriate units of desiccant and a humidity indicator card. It should not be opened until the modules are ready to be soldered onto the application.

11.2.1 Packaging

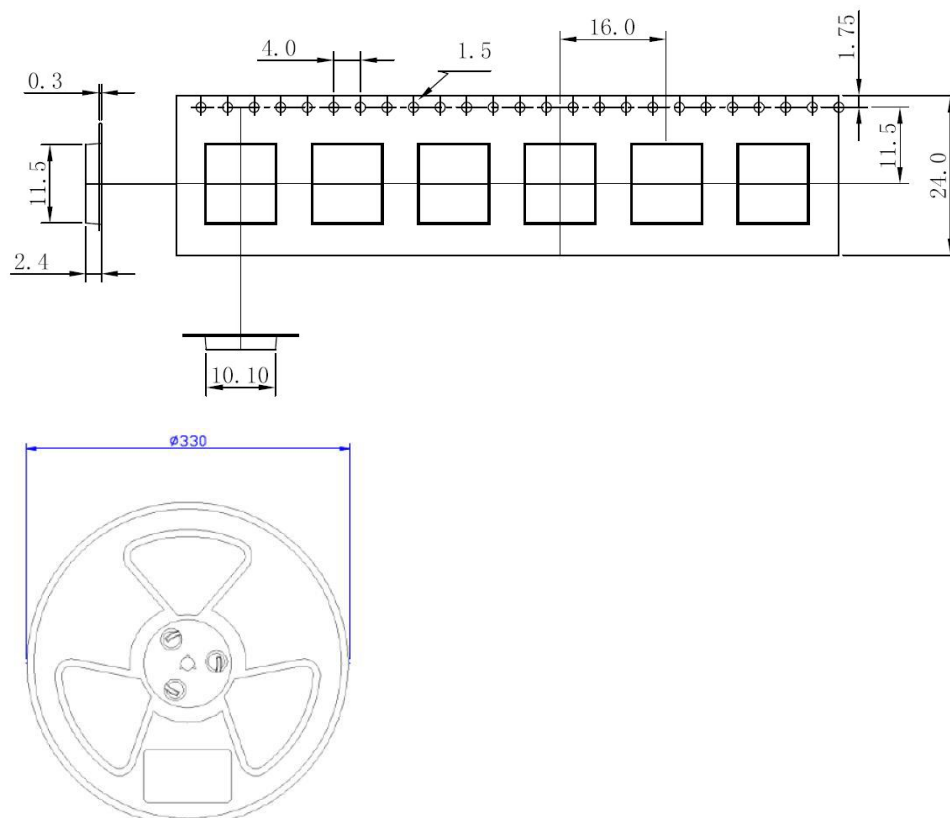

Unit: mm

Quantity per reel: 1,000pcs

Length per reel: 16m

Figure 7: Tape and Reel Specification

11.2.2 Box packaging

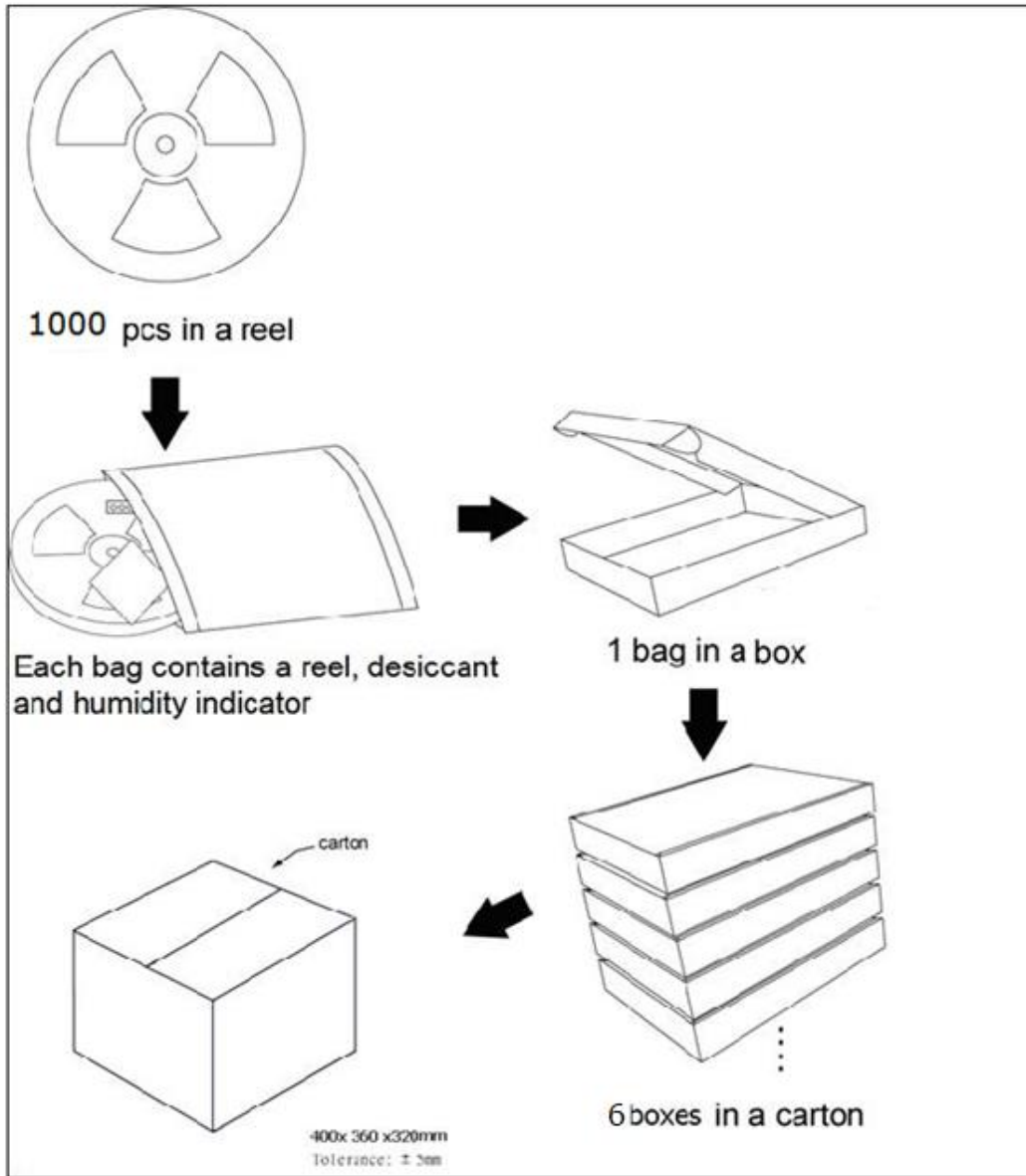

Figure 8: Packing method

Table 21: Reel Packing

Model Name	MOQ for MP	Minimum Package:1,000pcs
MG-1010-52Q	1,000pcs	SIZE: 365mm*348mm*50mm G.W: 0.98KG

11.3 Moisture sensitivity level

The moisture sensitivity level of the module is 3. After the sealed bag is opened, modules should be mounted within 168 hours at factory conditions of $\leq 30^{\circ}\text{C}$ and 60% RH or stored at $\leq 20\%$ RH.

The modules require baking before mounting if above conditions are not met. If baking is required, the modules without the tape and reel may be baked for:

- a. 192 hours at $40^{\circ}\text{C} + 5^{\circ}\text{C} / -0^{\circ}\text{C}$ and $< 5\%$ RH
- b. 24 hours at $125^{\circ}\text{C} + 5^{\circ}\text{C} / -0^{\circ}\text{C}$

11.4 Reflow soldering

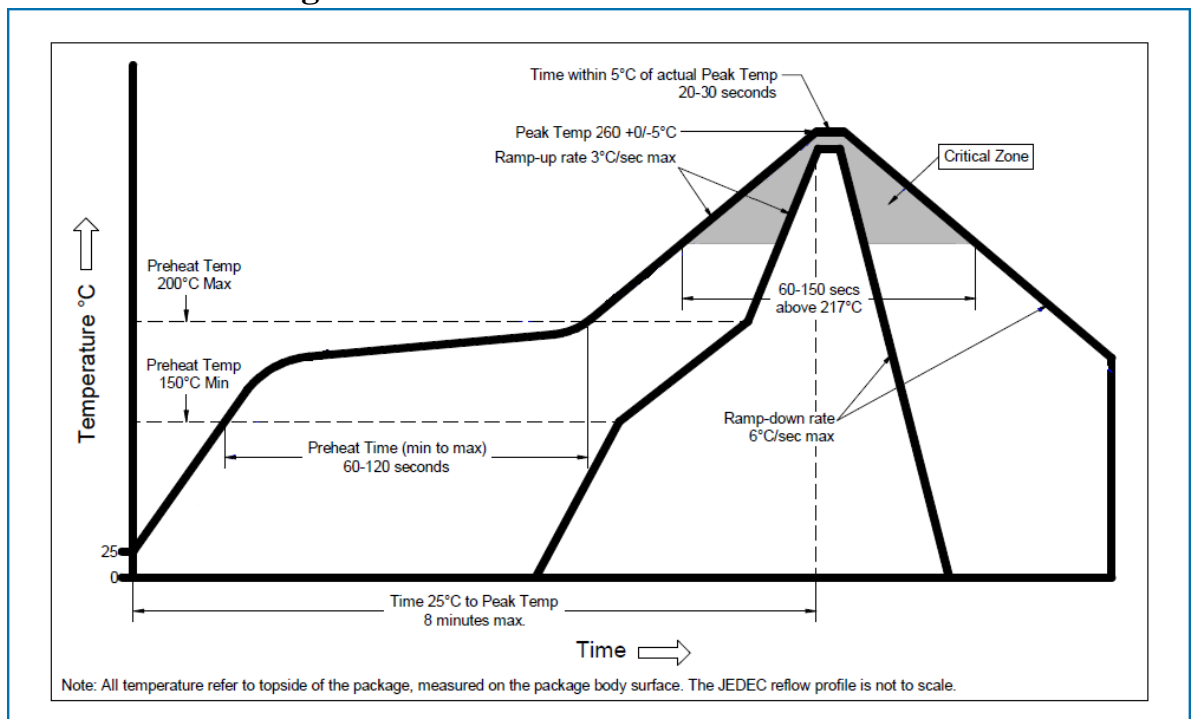

Figure 9: Ramp-soak-spike-reflow of Furnace Temperature

Note the module mounted to the top side (first reflow side) may fall off during reflow soldering of the bottom side.

12. Product marking and ordering information

12.1 Product marking

The marking of the module is engraved on the metal shielding that has product information, such as LOCOSYS logo, product name and manufacturing date.

12.2 Ordering information

Table 22: Ordering information

Product name	Description	Remark
MG-1010-52Q	Multi-constellation GNSS positioning module	GPS/QZSS: L1 C/A, L1C GLONASS: L1OF GALILEO: E1 BEIDOU: B1I, B1C

13. Document change list

Revision 0.1

- Draft release on Feb 22, 2023.

Revision 1.0

- Added the “Drone (UAV application)” in section 3.
- Added the UBX protocol support in section 5.
- Added the proprietary PLSC commands in section 7.3.